



**PVI 3000/PVI 4000**  
**PVI 5000/PVI 5300**

**INSTALLATION AND OPERATION MANUAL**

**Residential/Commercial**  
**Grid-Tied Photovoltaic Inverter**

© 2008, Solectria Renewables

Subject to Change REV 1.2.3

# IMPORTANT SAFETY INSTRUCTIONS

This manual contains important instructions that shall be followed during installation and maintenance of the PVI 3000, PVI 4000, PVI 5000 and PVI 5300 Inverter.

To reduce the risk of electrical shock, and to ensure the safe installation and operation of the inverter, the following safety symbols are used to indicate dangerous conditions and important safety instructions.



**WARNING:** This indicates a fact or feature very important for the safety of the user and/or which can cause a serious hardware damage if not applied appropriately.

**Use extreme caution when performing this task.**



**CAUTION:** Presents information to prevent damage to this product



**EARTH GROUND SYMBOL**



**NOTE:** This indicates a feature that is important either for optimal and efficient use or optimal system operation.



**EXAMPLE:** This indicates an example.

## SAVE THESE INSTRUCTIONS

# IMPORTANT SAFETY INSTRUCTIONS

- All electrical installations shall be done in accordance with the local and national electrical codes ANSI/NFPA 70, NEC. The PVI 3000-5300 inverters are listed to UL1741/IEEE1547 (and comply with IEEE 62.41).
- The PVI 3000-5300 contains no user serviceable parts. Do not open the inverter case as there are no used serviceable parts inside. Please contact Solectria Renewables or a Solectria Renewables authorized system installer for maintenance. (See appendix on page 48 or Solectria Renewables website, [www.solren.com](http://www.solren.com) for Solectria Renewables contact information and authorized system installers.)
- Before installing or using the PVI 3000-5300, please read all instructions and caution markings in this manual and on the PVI 3000-5300 unit as well as the PV modules.
- Connection of the PVI 3000-5300 to the electric utility grid must be done after receiving prior approval from the utility company and performed only by qualified personnel.
- Completely cover the surface of all PV-arrays with opaque (dark) material before wiring them or use other methods to ensure safety from shock hazard. PV arrays produce electrical energy when exposed to light and could create a hazardous condition.

## SAVE THESE INSTRUCTIONS

## Table of Contents

1	Introduction .....	5
2	Installation .....	8
	2.1 Checking for Shipping Damage .....	8
	2.2 Inverter Mounting and Placement .....	8
	2.3 Electrical Connection and Connection to Electrical Utility Grid, Surge/Lightning Arrestors and Grounding Electrode Conductors .....	16
	2.4 Connection of Communication Wiring .....	25
3	Commissioning the Inverter and PV System .....	27
4	Power, Ground Fault, Error LED Indicators and LCD Display .....	28
	4.1 Power, Ground Fault and Error LED Indicators .....	29
	4.2 The LCD Display .....	31
5	Trouble Shooting .....	39
6	Warranty .....	42
	6.1 Warranty Policy .....	42
	6.2 Return Material Authorization Policy .....	44
7	Technical Data .....	45
	Appendices .....	48
	Appendix A: PVI 3000-5300 Brochure / Datasheet .....	48
	Appendix B: Example PV String Sizing Tables .....	48
	Appendix C: Contact Information & Authorized Dealers and Installers .....	48
	Appendix D: Negative Grounding and Positive Grounding Option .....	49
	Appendix E: Fault Report Form .....	53
	Appendix F: UL1741/IEEE1547 Listing Letter .....	54

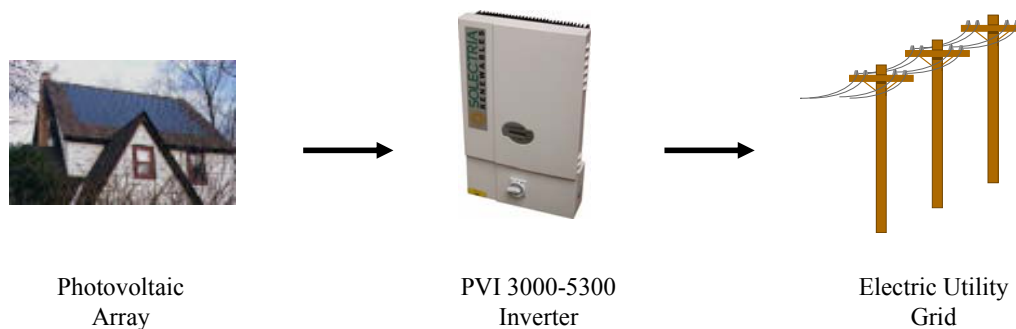
## 1 Introduction

The PVI 3000, PVI 4000, PVI 5000 and PVI 5300 are residential/commercial single phase, grid-tied PV inverters designed to be inter-connected to the electric utility grid. With this manual the PVI 3000 - PVI 5300 can be installed and operated safely. This installation guide is used as reference for commissioning and as a guideline on how to use the inverter most effectively.

Feeding power into the grid involves conversion of the DC-voltage from the PV-array to grid compatible AC-voltage by “inverting” DC to AC. This unit feeds power into a standard 240 VAC split phase electrical system or two legs (phase to phase) of a 208 VAC, 3-phase commercial, industrial or institutional facility’s electrical system that is connected to the electric utility grid.

If the PV system and inverter are providing the same amount of electrical power that the facility is using then no power is taken from or fed into the utility grid. If the facility is using more power than the PV system is providing, then the utility grid provides the balance of power. If the facility is using less power than the PV system is generating, then the excess is fed into the utility grid.

Be sure to look into local regulations regarding net metering/inter-connection in your local area. Note that some utilities need to change their revenue kWh meter for proper net metering measurement or incentives/billing.



**Fig. 1.1 Grid tied inverter application**

### The string PV concept

The use of string PV concept significantly reduces the cabling costs on a photovoltaic system. The use of strings of several PV modules in series and one, two, three (or in some cases four) parallel strings of PV modules has proven advantageous by delivering a high operating voltage to the solar inverter. This advantage is primarily reflected in a higher efficiency of the inverter. Careful optimization of the overall inverter system’s cost and efficiency lead to the choice of a 600V DC maximum system voltage for the power levels of the PVI 3000, 4000, 5000 and 5300 for use with 1kW to 7kW PV arrays per inverter.

## Data acquisition, display and communication

The integrated data acquisition, display and communication capability of the PVI 3000 - PVI 5300 allows comprehensive tracking of data for understanding of system performance. All error messages and operating conditions of the PVI 3000 - PVI 5300 as well as the PV system can be shown on the display. Downloading data from the PVI 3000 - PVI 5300 for analysis on a PC is also possible over the data interfaces (RS232 or 485).

These functions allow complete and continuous monitoring of the photovoltaic system. Read-out of data over the integrated interface and its display is only possible when the solar system is in operation.

An optional full-featured, “inverter-direct” data acquisition and logging gateway and web-based service is available from both Solectria Renewables and Fat Spaniel. You have the option to purchase from either company. The gateway plugs into the inverter and to the facility’s internet service.

## Technical structure of the PVI 3000, PVI 4000, PVI 5000 and PVI 5300

A high frequency switching bridge circuit operating in connection with a high frequency transformer provides galvanic isolation of the photovoltaic system from the building’s AC power (and electrical utility grid). The PV voltage and current are optimized in such a way that fluctuations which are caused by differing sunlight strengths and PV module temperatures can still end up producing the maximum possible power.

Internal regulation of the PVI 3000 - PVI 5300 is achieved using microcontrollers, which control the function of MPP (Maximum Power Point) tracking.

The input PV voltage window is designed to cover a range of 200 to 550 VDC from the PV array (600VDC maximum open circuit voltage). This means that many combinations of modules and strings from different manufacturers can be used.

The inverter has nearly no standby power consumption and night-time losses (0.2 W). Even when running, the control circuit power use of the inverter is reduced to a minimum, which helps give the inverter high operational efficiency.

The housing and heat sink for the PVI 3000 - PVI 5300 is manufactured using a heavy aluminium extrusion with an anti-corrosion finish. The housing is designed to NEMA3 to be resistant to rain and snowfall. The heat sink and fan are designed in such a way that operation of the inverter is possible at ambient temperatures of -13° F (-25° C) to +131° F (+55° C) at full rated power (at 240VAC or 208VAC – note AC power output is slightly less at 208VAC than 240VAC).

The heat sink serves to conduct away heat generated from energy losses in the power electronics. Internal temperature regulation provides protection against excessively high temperatures inside the PVI 3000 - PVI 5300. The maximum power processed from the PV array is automatically reduced to limit excessive inverter temperature.

The PVI 3000 - PVI 5300 will only operate in parallel with the utility grid. AC grid monitoring is done by microcontrollers configured to meet the requirements of UL1741/IEEE1547. This includes grid voltage or frequency fluctuations outside of the required limits, anti-islanding and other limitations and requirements, which ensure that the inverter shuts down immediately if the grid goes down, or if the grid gives surges, sags, changes frequency or otherwise shows signs of instability. If this happens, the inverter will check the grid and reconnect to the grid 5 minutes after the grid is back to normal. (The display then shows: “Waiting for restart”.) Disconnecting from the grid is important to protect the electrical and utility line workers who may be working to restore the grid as well as electricians working at a site with PV systems.

Power grid faults that will cause the PVI 3000 - PVI 5300 to isolate itself from the power grid:

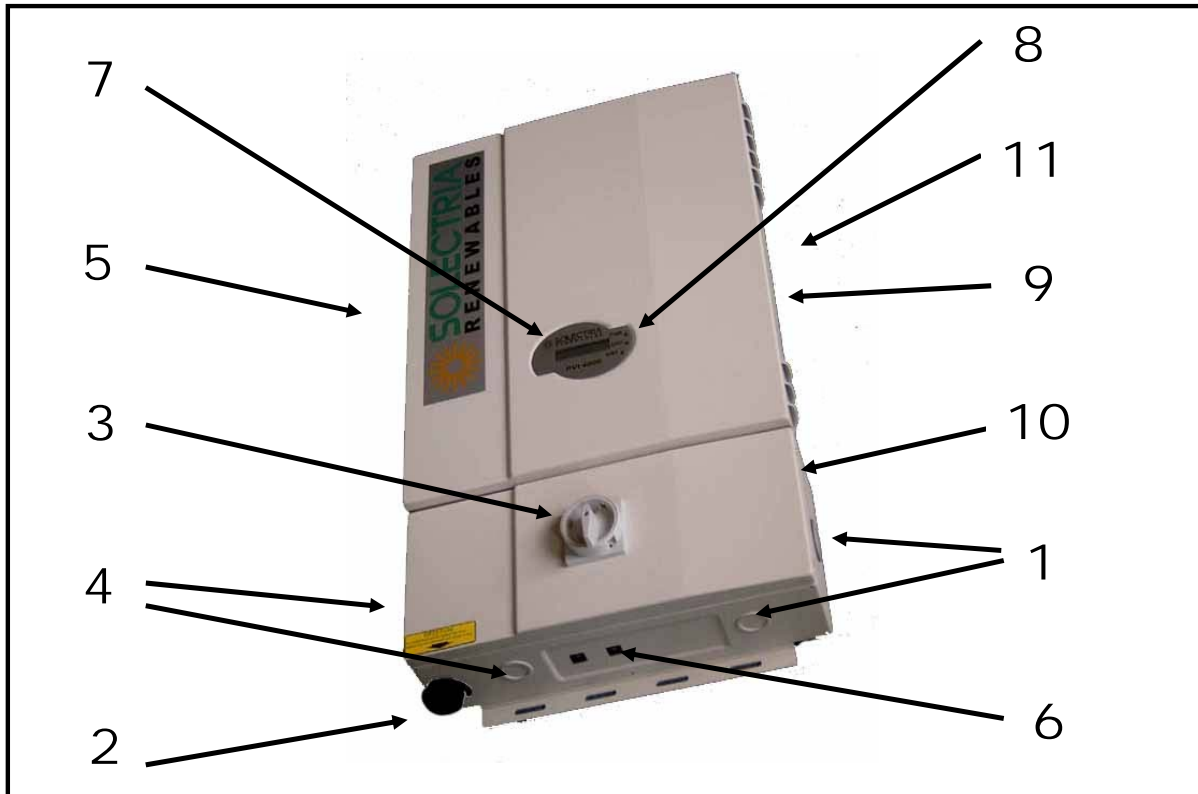
- AC grid voltage

The grid voltage must not go outside the range of +10/-12% of the nominal 240 or 208V AC grid voltage (as per IEEE Std 1547, § 4.2.3). The inverter will isolate itself from the power grid if these limits are exceeded either way. The PVI 3000 - PVI 5300 is factory set to 208 or 240VAC. The inverter will automatically detect and sync to 240 or 208VAC when connected to the neutral. If it is desired to connect to 208 or 240VAC without a neutral connection, then the inverter must be set at the factory or adjusted by a qualified installer. A qualified installer can reconfigure the grid voltage setting in the field using jumper adjustments inside the inverter.

- AC grid frequency

The power grid frequency can be within a range of +0.5Hz, -0.7Hz of the nominal 60Hz grid frequency (as per IEEE Std 1547, § 4.2.4). The inverter will isolate itself from the power grid if these permitted limits are exceeded either way.

Another important safety feature is galvanic isolation of the utility grid and the PV array as well as ground fault detection and interrupt (GFDI) of the PV array. The PV array negative is grounded inside the inverter (and must not be grounded at any other point).



**Diagram of the PVI 3000/4000/5000/5300 Features**

- (1) AC knockouts (and on back)
- (2) PV array ground fault interrupt (GFDI) fuse
- (3) DC disconnect
- (4) DC knockouts (and on back)
- (5) Fan assembly (on back at bottom of heatsink, used on PVI 4000/5000/5300 only)
- (6) RS-232/485 interfaces
- (7) LCD display
- (8) LED indicators for basic operating status
- (9) Inverter Serial Number
- (10) Detachable wiring box
- (11) Quick-mount wall plate (behind unit)

**Fig. 1.2 PVI 3000/4000/5000/5300 Features Diagram**

## 2 Installation



**WARNING:** Before installing the PVI 3000-5300, read all instructions and caution markings in this manual and on the PVI 3000-5300 as well as on the photovoltaic modules.



**WARNING:** Electrical installation shall be done in accordance with all local electrical codes and the National Electrical Code (NEC), ANSI/NFPA 70.



**WARNING:** Connecting the PVI 3000-5300 to the electric utility grid must only be done after receiving prior approval from the utility company and installation completed only by qualified personnel/licensed electrician(s).

### 2.1 Checking for Shipping Damage

The PVI 3000/4000/5000/5300 inverters are thoroughly checked and tested rigorously before they are shipped. Even though they are delivered in a rugged, heavy cardboard box, the inverters can be damaged in shipping.

Please inspect the inverter thoroughly after it is delivered. If any damage is seen please immediately notify the shipping company. If there is any question about potential shipping damage, contact Solectria Renewables. A photo of the damage may be helpful.

Do not accept unit if visibly damaged or note visible damage when signing shipping company receipt. Report damage immediately to the shipping company. Do not remove the unit from packaging. If it is determined that the unit must be returned, an RMA# must be obtained from Solectria Renewables.

### 2.2 Inverter Mounting

The PVI 3000/4000/5000/5300 inverter is made up of a sealed NEMA 3 corrosion resistant, painted aluminum enclosure containing all electrical and electronic components.



**NOTE:** If the PVI 3000/4000/5000/5300 is mounted outside, make sure the mounting & wiring is completed, at least to the AC and DC disconnects or junction box(es) in case of rain during the installation process (for example overnight rain). Since the AC and DC connections are wired to the wiring box, disconnects and or junction box(es) only, there is no need to open the main inverter enclosure during hook-up. The inverter enclosure is factory sealed and must NOT be opened at any time in the field as this will void the warranty.

## Notes regarding mounting and placement of the inverter

#### Criteria for device mounting:

- Because the inverter is in a NEMA3 enclosure, the inverter can be mounted outdoors.
- The very longest life for the inverter can be achieved by mounting it in a clean, dry and cool location even given the unit's robust construction and design for efficient cooling. It is recommended to keep the unit out of direct rain. Protection from a roof overhang, awning is better if the unit cannot be mounted indoors or in a shed, garage or basement.
- For optimal electrical efficiency, use the shortest possible AC and DC wires and use the maximum allowable wire size. (Depending on which model inverter, 8-10AWG minimum is recommended for all connections, both AC and DC.)
- Avoid installation in close proximity to people or animals, as there is a small amount of high-frequency switching noise.
- Install the inverter in an accessible location following NEC and local codes. Note NEC requirements for clearances and proximity to other equipment and building walls.
- Although not required, installation at eye-height allows easy reading of the indicator LEDs and the LCD display.
- For optimal inverter life and performance, do not mount the inverter in direct sunlight, especially in hot climates, although the inverter is designed to function at full power continuously in up to 131° F (55° C) ambient temperatures. In hot



climates if the unit must be mounted in direct sunlight a silver or white metal sun-shield is highly recommended. It is recommended that the inverter be mounted on the north (or east) side of buildings or on the north side of a PV array (which can provide some shade). Following these guidelines can help prevent the unit from going into de-rating due to excessively high inverter case temperature.

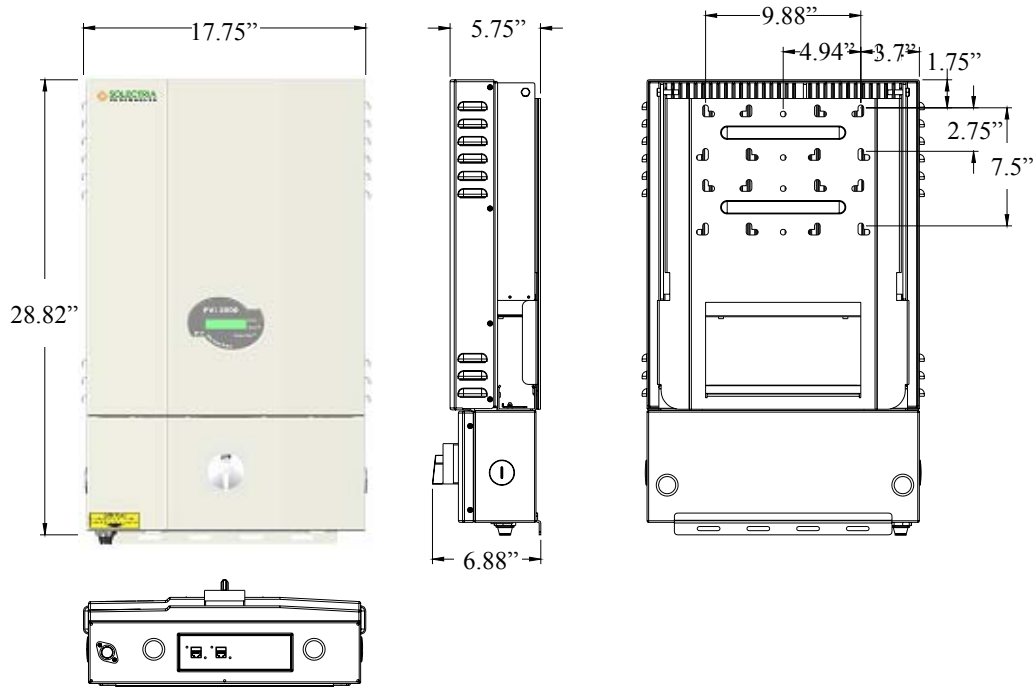
- In hot climates, the housing and heat sink can reach 160° F (70° C) and must be mounted on an appropriate material for this temperature as well as one that meets NEC and local codes. The inverter should not be mounted where people are likely to touch the case or heat sink due to the high potential temperature.



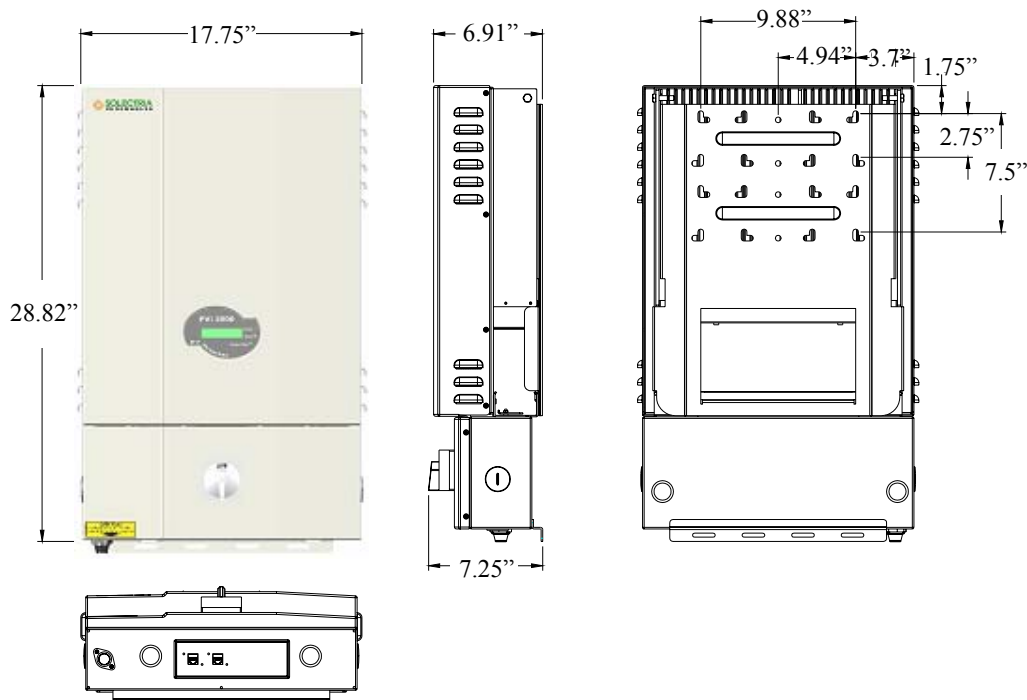
**CAUTION:** Please follow these guidelines:

- The inverter weight is about 47-60 lbs. (21.4-27.3kg) depending on model. Be sure method used for fastening the unit to the wall will safely hold this weight.
- The ambient temperature must be between -13° F (-25° C) and +131° F (+55° C) for full continuous, full power operation. (The inverter will automatically reduce power or shut down to protect itself if the ambient air temperature rises above 131° F (55° C).) Humidity shall be within 0% and 95%.
- The National Electrical Code (NEC) requires that the inverter be connected to a dedicated AC circuit and no other AC outlets or device may be connected to this circuit. See NEC Section 690.64. The NEC also imposes limitations on the size of the inverter and the manner in which it is connected to the utility grid. See NEC Section 690.64.
- The cooling air enters at the bottom of the heat sink and exhausts at the top of the unit. See diagrams below for recommended clearances for cooling air and space around the inverter.
- If you are installing the inverter in a utility vault or electrical closet, the air circulation must be sufficient for heat dissipation – provide external ventilation, to maintain an ambient condition of less than 131° F (55° C). The ambient temperature should be kept as low as possible.
- Use the dimensional diagrams below for correct mounting of the inverter.

**PVI 3000/PVI 4000 DIMENSIONAL DIAGRAM**



**PVI 5000/PVI 5300 DIMENSIONAL DIAGRAM**



**Fig. 2.1 PVI 3000/4000/5000/5300 Dimensional Diagram**

### Placement and location

- PVI 3000/4000/5000/5300 inverters that must be vertically mounted may be located indoors or outdoors, given the NEMA 3R rating.
- Avoid mounting the inverter on a location where is exposed to direct rain.
- Leave at least 20" of free space above and 40" below the inverter for best ventilation (see Figure 2.1.1).
- Mount the inverter on a wall that is strong enough to support the 47-60lb inverter.



**WARNING!**

Some parts of the heatsink can reach temperature over 160F (70°C). Keep flammable and explosive materials at an appropriate distance from the inverter!



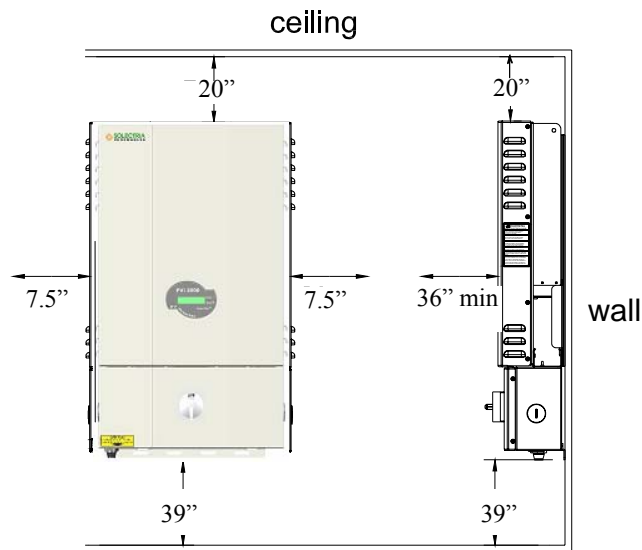
**WARNING!**

Do not expose the inverter to corrosive liquids and/or gases.

- Keep AC and DC wiring as short as possible to minimize power loss.
- Mounting bracket should be fastened to a concrete or a masonry wall using appropriate anchors.

### Conduit Locations, Pre-punched Holes and Knock-outs

- Holes are pre-punched (and shipped with hole covers) for 1" conduit fittings on the left and right sides of the wiring box, these holes are centered at 2.5" from the wall mounting surface.
- 3/4" and 1" concentric KOs are on the bottom of the AC and DC sides of the wiring box and these are located 2.63" from the wall mounting surface.
- 3/4" and 1" concentric KOs are on the back of the AC and DC sides of the wiring box for routing wiring out the back of the box into the wall for a "hidden wiring" installation.

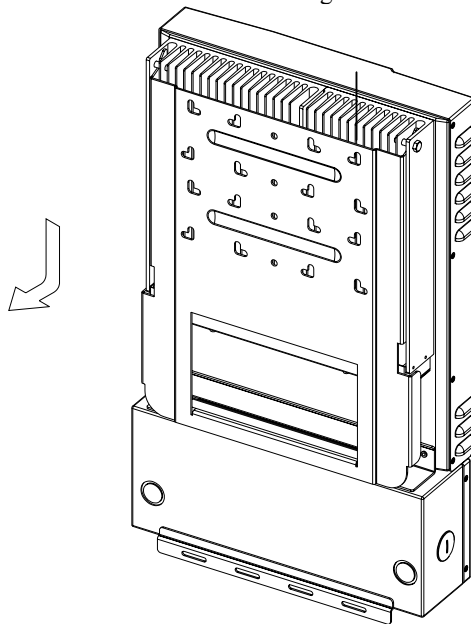


**Fig2.1.1 Clearances recommended for PVI 3000/4000/5000/5300 inverter installation**

**Mounting details**

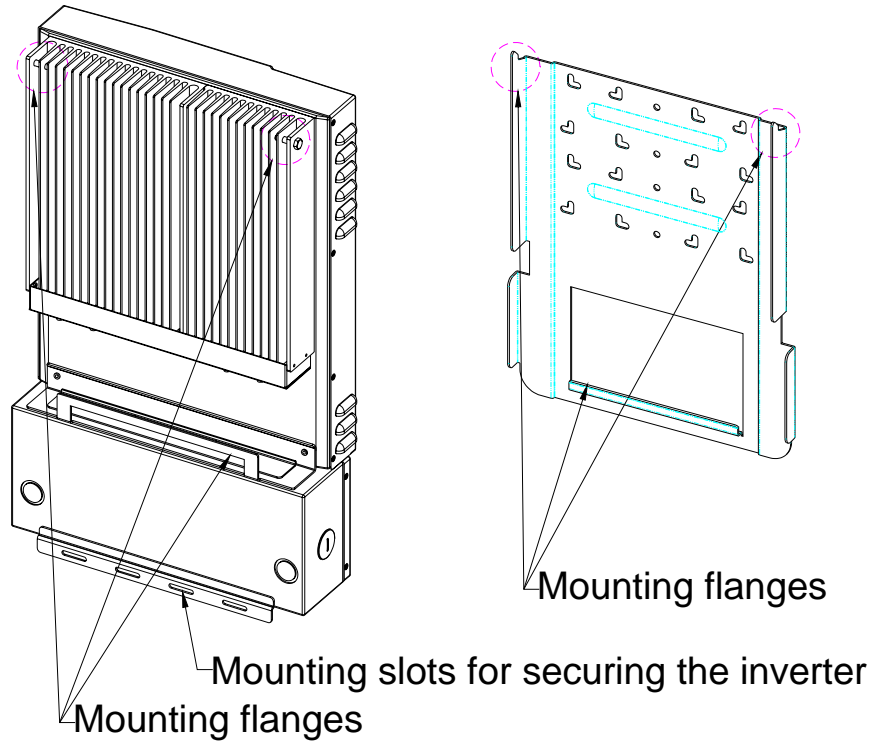
The steps listed below describe how to mount the inverter on the wall:

- After taking the inverter out of the cardboard box, you will find the bracket in the bag behind the heatsink. First, the bracket needs to be removed from the inverter as shown in the figure 2.2.1 below.



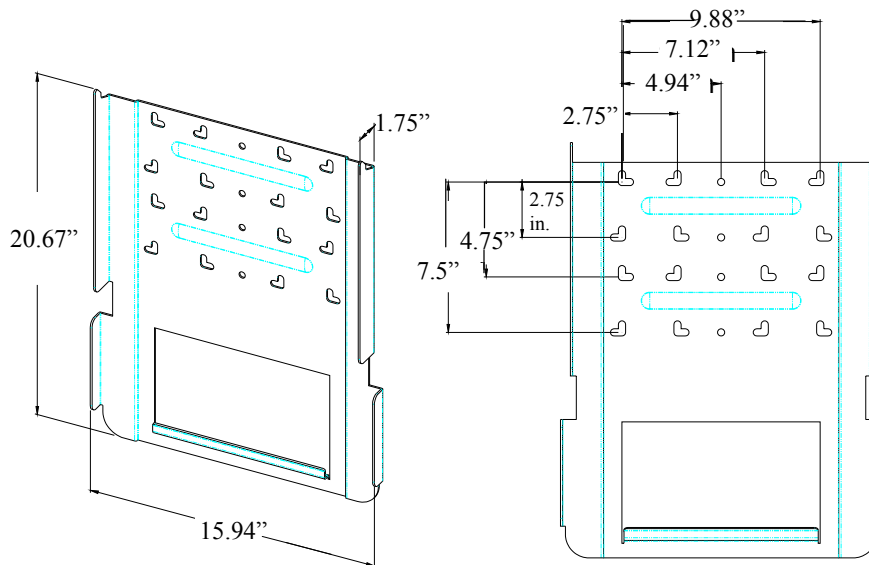
Back side of the inverter

Mounting bracket

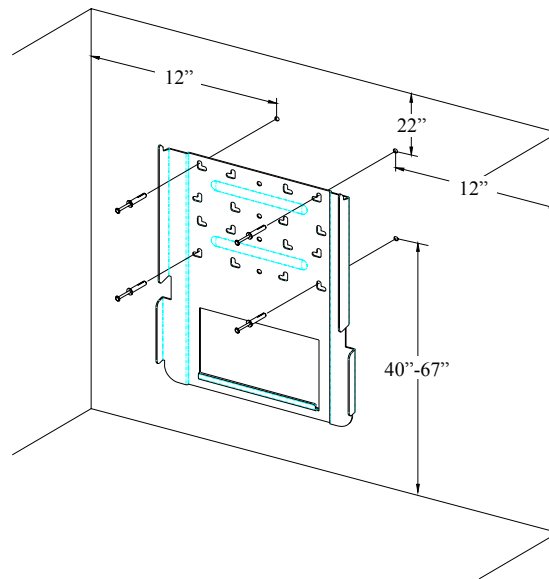


**Fig 2.2.1 Remove the bracket from the inverter**

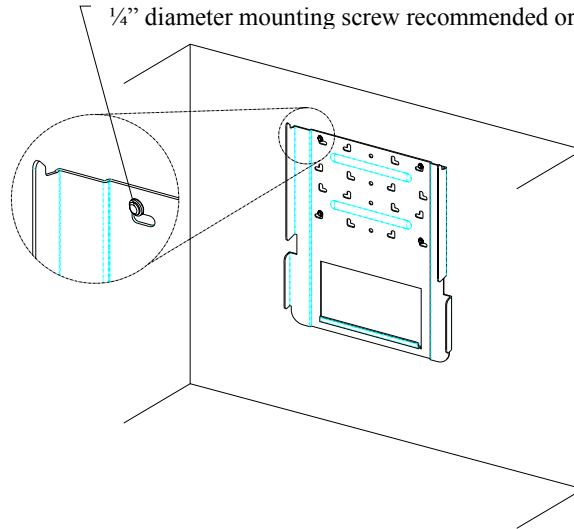
1. Use the bracket (Fig 2.2.2) as a template to mark the locations on the wall where holes should be drilled. After drilling the holes, the mounting bracket should be fastened to the wall with screws or screw-anchors as shown in Figure 2.2.3.



**Fig 2.2.2 The mounting bracket and its dimensions**

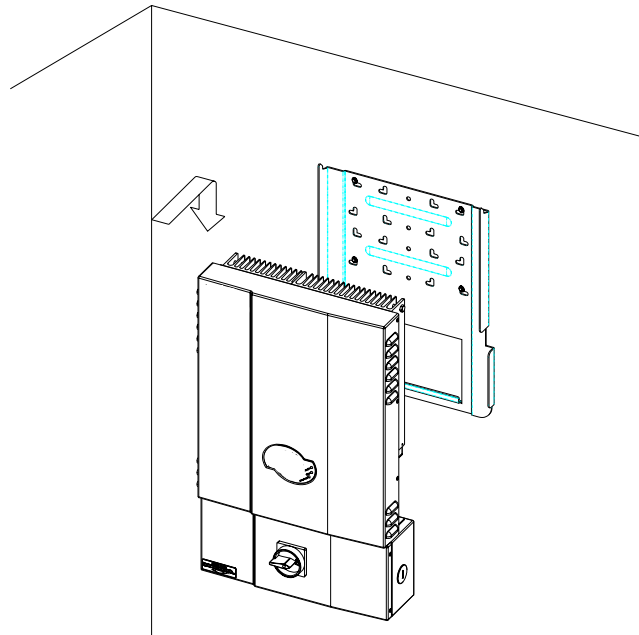


1/4" diameter mounting screw recommended or 3/16-1/4" anchor bolt (as shown above)

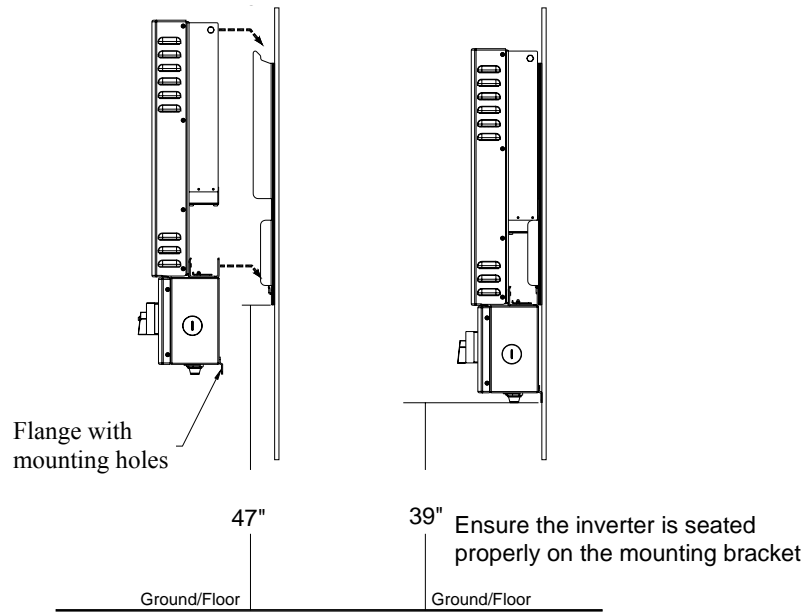


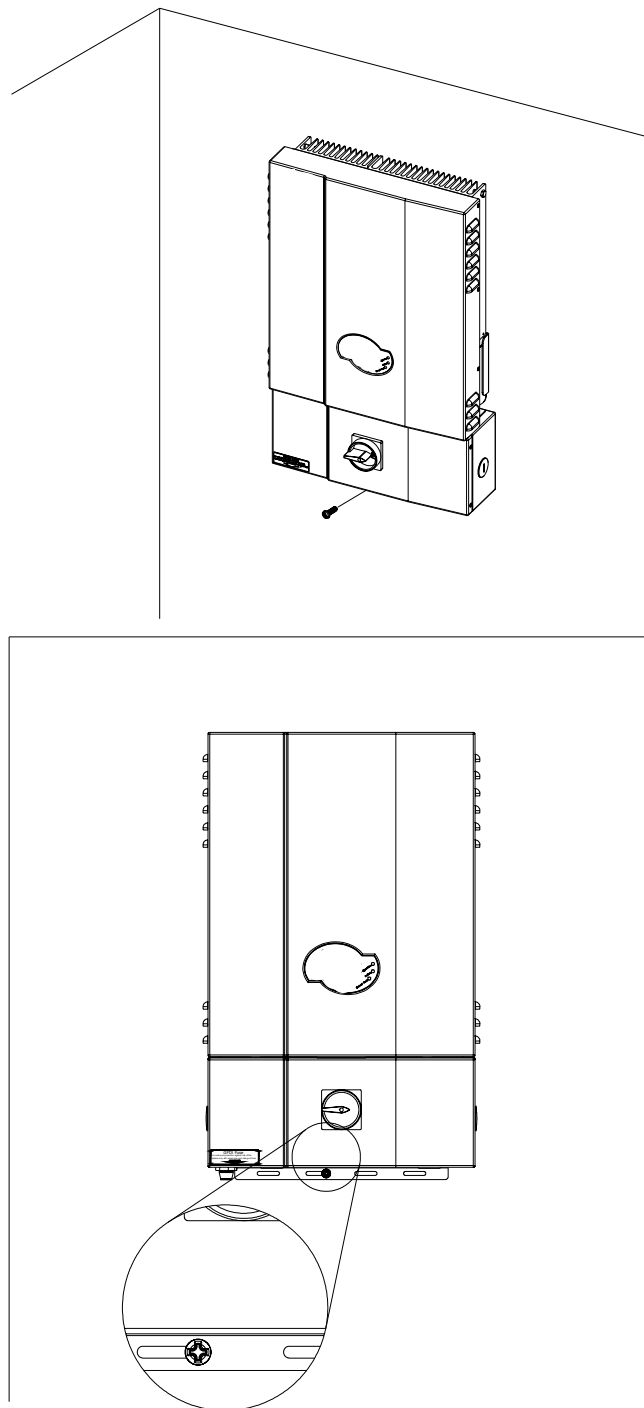
**Fig 2.2.3 Fastening the mounting bracket**

2. Once the mounting bracket is fastened to the wall, then the inverter and the wiring box (that are attached together) can be hooked onto the bracket and slipped down into place. Make sure the lower lip on the bracket hooks into the window on the back of the inverter as shown in 2.2.4 below.



Slide the mounting bolts at the top of the inverter over the hooks on the mounting bracket

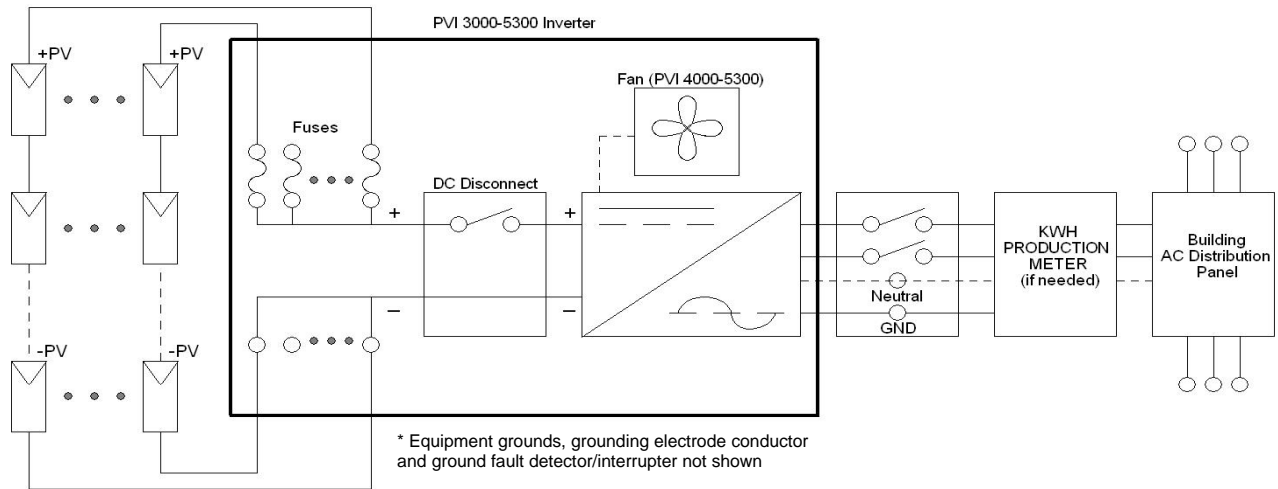




**Fig 2.2.4 Hook the Inverter on the mounting bracket and then fasten with a screw at the bottom flange**

After the inverter is hooked properly on the bracket and secured with a screw at the bottom flange, then the inverter can be wired.

## 2.3 Electrical Connection and Connection To Electrical Utility Grid



PVI 3000-5300 PV SYSTEM BLOCK DIAGRAM

Fig. 2.3 Simplified electrical connection diagram

### Location and Mounting the Inverter



**NOTE:** Choose the inverter location keeping in mind where any additional disconnects, junction boxes and/or AC kWh meter (if needed) will be located. One good idea is to mark on the wall (or create a diagram) where all of the components are to be located. The inverter is set up with an integrated DC disconnect and fused PV combiner to make it very easy and quick to connect the inverter.

Refer to Figure 2 for Locations of Features, AC and DC Wires, etc.



**WARNING:** All electrical installations shall be done in accordance with all local electrical codes and the National Electrical Code (NEC), ANSI/NFPA 70.

The negative DC photovoltaic connection is grounded within the inverter through the ground fault detection and interrupt circuit (GFDI). The PV negative should not be grounded at any other point in the system. The PV positive must never be grounded at any time. (Note that this is reversed for systems using the positive grounded option.)

### AC and DC (PV) Connections:

The PVI 3000-5300 inverters are equipped with covered holes and KOs to fit conduit fittings that are NEC code-compliant for use with several sizes of rigid and flexible metallic or non-metallic conduit. All conduit and wiring installation is done in the wiring box. This design allows installation and wiring of the inverter to be done without opening the main inverter enclosure which should not be opened during installation.

### Lightning and Surge Protection:

The inverter is designed with certain protections against surges in voltage including certification to UL1741/IEEE1547 (including ANSI/IEEE 62.41/62.42 as required in the NY SIR), however added protection and solid grounding provisions are important for best protection against utility surges and surges created by indirect lightning strikes.



The installation of a Delta lightning surge arrester or other UL listed arrester of the correct specification is recommended on both the DC and AC sides of inverter. Solectria and various distributors stock these arresters. They can be installed on the outside of the wiring box or other locations in the system and wired using the manufacturer's directions. This device gives important added protection from indirect lightning strikes and resulting surges that provide protection beyond the inverter's UL1741 requirements. It is suggested to drive a ground rod specifically for the PV array. It is also a very good idea to have the lightning protection system of the building checked and upgraded if needed before the PV system is installed. (are there air conductors / rods along the roof line of the building above the PV array? Do you see a copper ground wire running from the air conductors to a ground rod?) These added protections are especially important for areas prone to thunder storms and possible nearby lightning strikes. Although these added precautions will not guarantee that there will be *no* damage from lightning, they can help prevent or limit potential damage.

**Grounding Electrode Conductor:**

As with all PV systems, a Grounding Electrode Conductor must be installed per NEC690.47 (and 250.166). This conductor should be sized according to these NEC requirements. This conductor should be terminated on the labeled ground point located at the bottom of the wiring box where the DC and AC equipment ground conductors also are terminated.



**WARNING:** The inverter should not be opened at any time unless authorized by Solectria. The unit is sealed at the factory and its UL listing will no longer be valid and the warranty will be void if opened or tampered with in any way.

**AC Voltage:**

The PVI 3000-5300 are 240V AC grid connected devices. They are also both suitable for 208V AC grid-connected use. For example, connection to 2 phase legs of a 208V AC, 3-phase service (where acceptable by code). **No unit (PVI 3000, 4000, 5000, or 5300) can be used with just a 120V AC connection.** The units are factory pre-set for auto-detect 240VAC and 208VAC when connected with a neutral. They can also be configured for connection without a neutral at the factory or by a qualified installer.

**Multiple Units:**

Multiple PVI 3000-5300 units can be used at the same location/facility assuming all codes are followed including NEC, local building codes and area utility guidelines. If multiple units are used, each inverter should have its own dedicated circuit breaker, and a PV string must only be wired to one inverter (although multiple PV strings can be used on each inverter up to unit ratings and power levels).

**AC Circuit Breakers:**

A dedicated AC circuit breaker in the home or building circuit panel is required for the PV inverter. Every PVI requires a 208/240V AC rated 2-pole circuit breaker. The following is a table showing the appropriate circuit breaker for the PVI 3000, 4000, 5000, and 5300 (based on number of Amps).

PV Inverter Model	PVI 3000	PVI 4000	PVI 5000	PVI 5300
Circuit breaker used (Amp)	20	25	30	30

**AC and DC Disconnects:**

The DC disconnect is a standard feature of the PVI 3000-5300 inverter. It is recommended that the PV system AC disconnect (if required by the utility or local inspector) be located beside the inverter or in an outdoor as required to conform to local code for your installation. If local code requirements call for the AC and/or DC disconnect(s) to be mounted in another location, you can consider relocating the inverter also to the required location to provide the DC disconnect.

**Suggested AC Disconnect (if needed): 240V AC, 30A, 2 Blade, NEMA 3R**

	Part Number	Manufacturer
Rain-proof NEMA 3R, no fuse	DU221RB	Square D
Rain-proof NEMA 3R, fusible	TG3221R	GE
Rain-proof NEMA 3R, no fuse	TGN3321R	GE
Pull-out disconnect, 3R, no fuse	3800	Millbank

For some installations, code compliance may include indoor, NEMA 1 rated disconnects which are less expensive. For whichever disconnect is selected, you will also need the proper listed ground bar kit. (No neutral kit is needed, as no neutral line should enter the disconnect.)

### **Connecting the AC Inverter Wiring:**



**WARNING:** The wiring of the PV inverter's AC and DC connections must only be done with the building AC circuit breaker off and the PV array disconnected or covered with an opaque material (or other method to assure the PV wiring is not live). Both AC and DC should be disconnected or turned off.

The PVI 3000-5300 inverters are not capable of back-feeding currents into the PV array from the AC source including into short circuit(s) or fault(s) in the PV array or string(s).

### **PV String Configurations:**

There is a huge number of PV module string combinations that will work well with the PVI 3000-5300 inverters given the very large DC voltage range in which the inverter can operate. See string sizing in Appendix B for some examples. This appendix also refers to a complete string sizing resource online.

### **Connecting the DC (PV) Inverter Wiring:**



**WARNING:** Follow PV module manufacturer's directions. PV-arrays produce electrical energy when exposed to light and could create a hazardous condition. (One method used to assure safety from shock is to completely cover the surface of all PV-arrays with opaque / dark material before wiring them.) Alternatively, keep all PV module connectors disconnected (but don't leave PV module connectors open in rainy weather or when leaving the jobsite.)



**WARNING:** Before connecting the connectors of the PV-panel to the DC inverter terminals, check the correct polarity and admissible PV-panel voltage between the (+) and the (-) cable connectors of the PV panel. (Note that the mating connectors used to connect to your array junction box may have reversed polarity markings.)

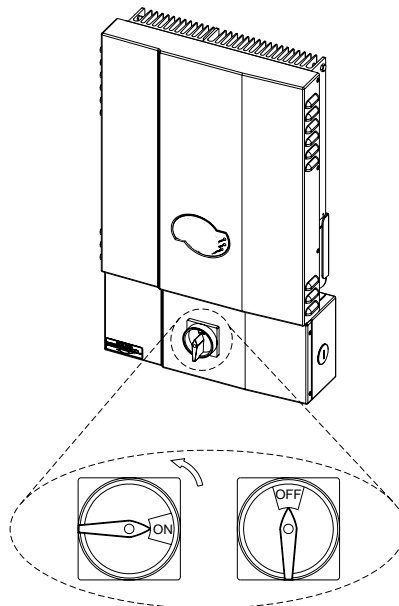
The PV-panel open circuit voltage must be below 600V DC ( $V_{pv} < 600V$  DC) under all conditions as per NEC 690-7 using multiplier for cold weather OCV, or using PV module manufacturer's specifications. Please read the Technical Info section and see PV string sizing table in Appendix B.



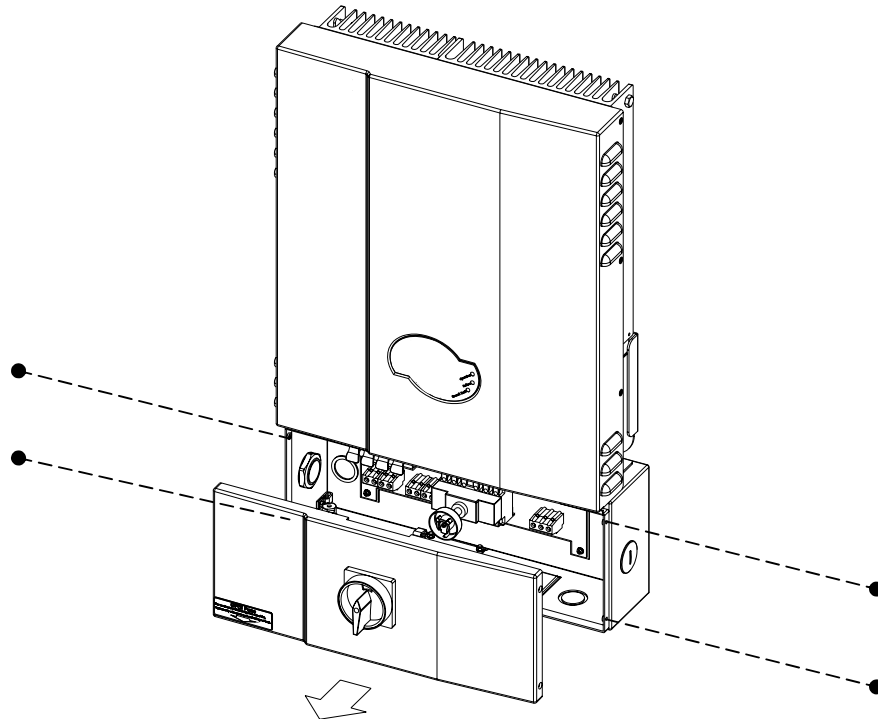
**WARNING:** Even when in the off position, the DC disconnect will remain live on the PV side ("line") when the PV modules are in daylight.

### **Wiring the inverter**

The cover of the wiring box needs to be removed before wiring the inverter. First the DC switch shall be turned to the OFF position as shown in the Figure 2.3.1. and then remove the 4 screws; remove the cover of the wiring box shown in the figure 2.3.2 and 2.3.3 below.

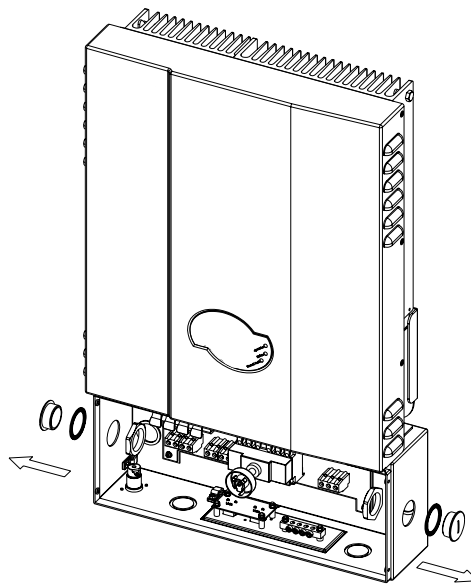


**Fig 2.3.1 Turn the DC switch OFF**



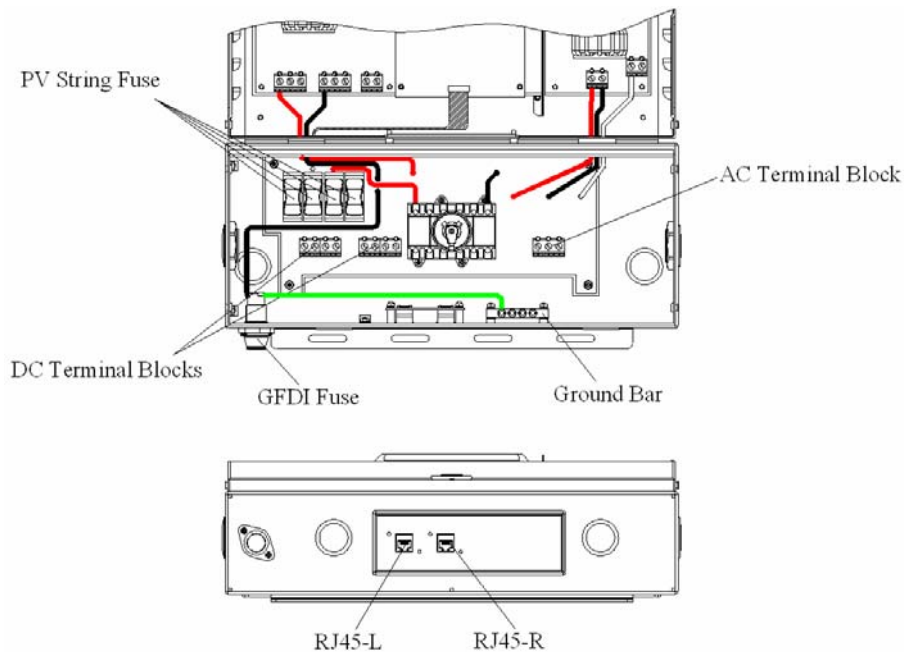
**Fig 2.3.2 Remove the 4 screws on the wiring box Fig 2.3.3 remove the cover from the wiring box**

After the wiring box cover is removed, the conduit hole covers can be removed (or KOs in other locations punched out) as shown in the figure 2.3.3 for the DC and AC conduits which will enter and exit these locations.



**Fig 2.3.3 Remove the hole covers where the conduits will enter and exit.**

The following three sections describe the wiring for the AC, DC, and communication ports. The AC and DC wiring shall be done in the wiring box of the PVI 3000/4000/5000/5300. There is a pair of DC terminal blocks, two (2) RJ-45 connectors, and one (1) AC terminal block in the wiring box as shown in the Figure 2.3.5. The DC terminal blocks are used to connect up to 4 PV strings that will parallel connected in the wiring box (3 strings for the PVI 3000). The RJ-45 connectors are used for external communication to a remote computer or communication gateway. The AC terminal block is used to connect to the building/utility grid through a circuit breaker in the building distribution panel.



**Fig 2.3.5 Wiring box bottom view**



**WARNING!**

All electrical work shall be done in accordance with the local and national electrical codes and with the National Electrical Code (NEC), ANSI/NFPA 70 and should follow the important safety instructions in this manual.



**WARNING!**

The National Electrical Code (NEC) states that the inverter must be connected to a dedicated circuit, and that no other outlets or devices can be connected to the same circuit. The NEC also imposes limitations on the size of the inverter and the manner in which it is connected to the utility grid.



**WARNING!**

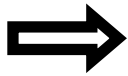
Make sure that you use suitable conductors for both the AC and DC wiring. The cables must be adequately sized and of correct temperature rating and sunlight resistant if needed. Use #10 AWG to #6 AWG, 90 °C (194 °F) copper wire for all AC and DC wiring connections to the PVI 3000/4000/5000/5300 inverter.



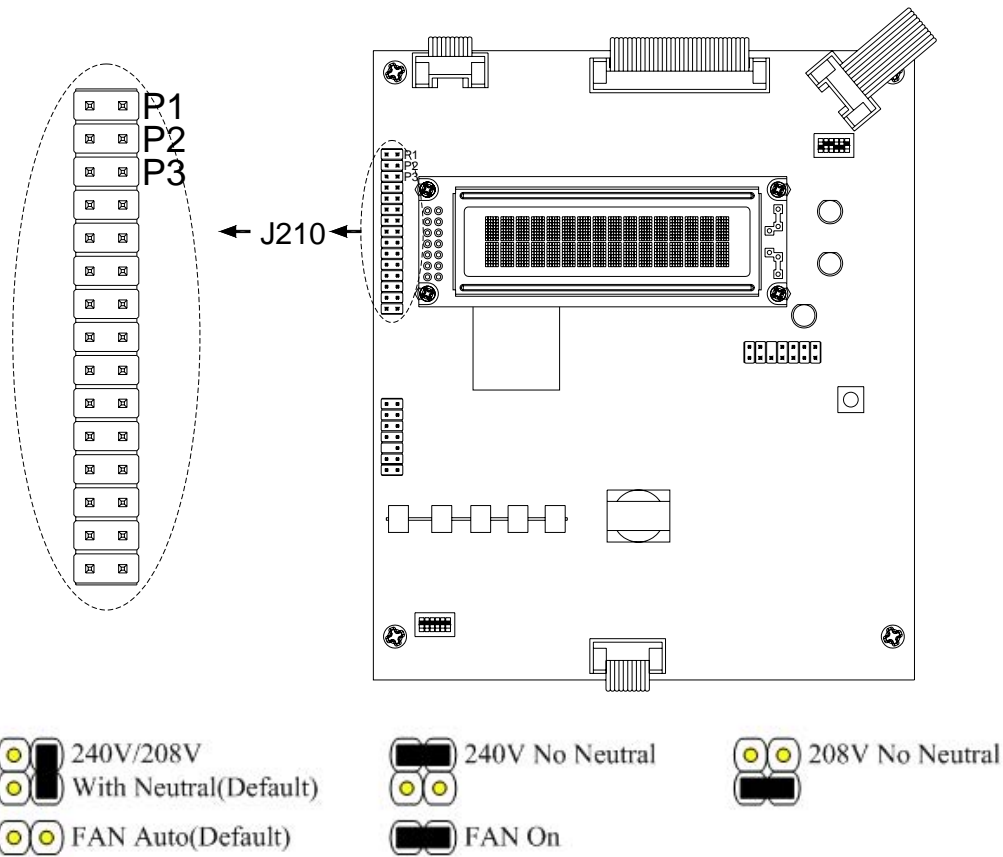
**WARNING!**

PV arrays will be energized when exposed to light. Cover the arrays with opaque (dark) materials during installation and wiring, and/or keep module leads disconnected.

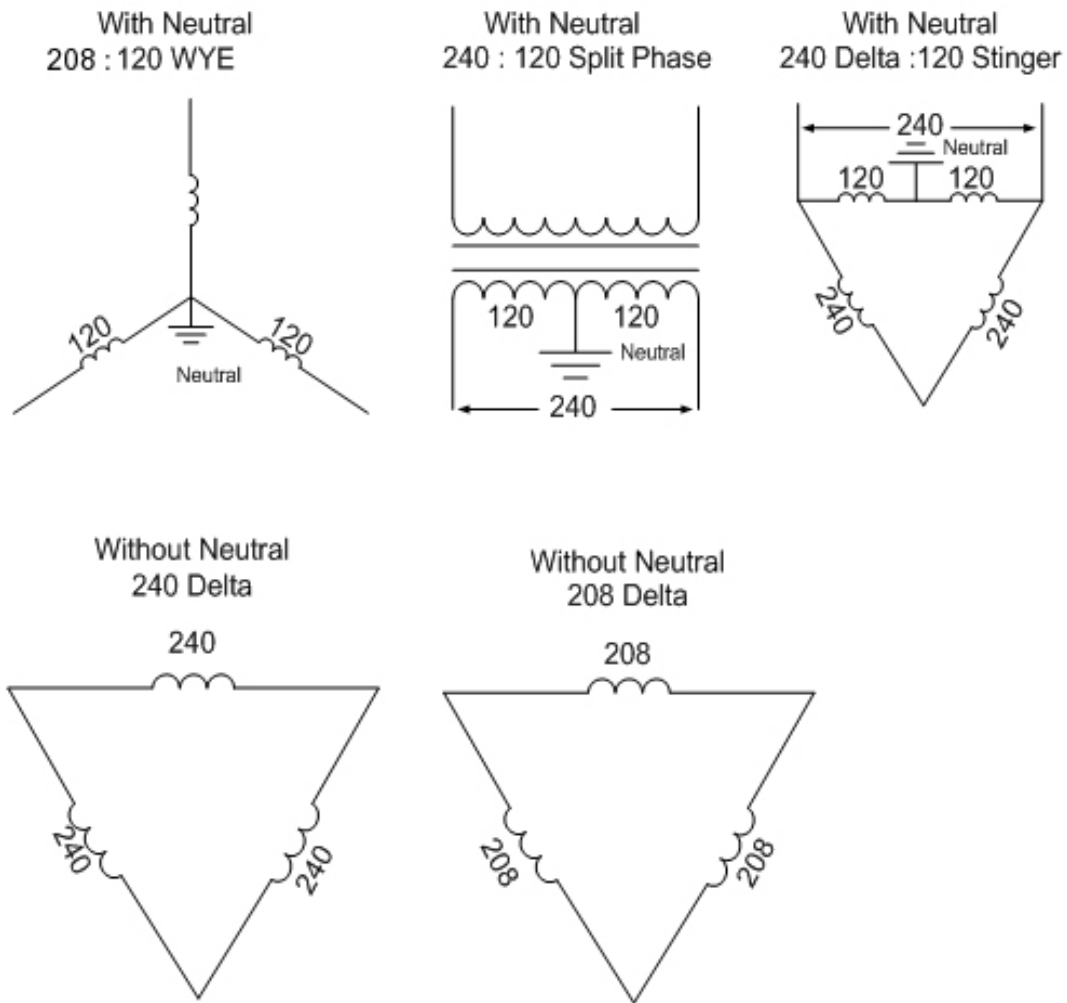
Before wiring the PVI 3000-5300 inverter, the installer needs to determine the grid connection/ utility configuration that the inverter will be connected to. The PVI 3000-5300 inverter is default set for utility interconnection with a neutral connection. However, it may be reconfigured for a connection without a neutral. The utility configuration jumpers, J210, are located on the control board as shown in the figure 2.3.6 are used to set the PVI 3000-5300 inverter to be connected to the commonly used utility configuration types shown in the figure 2.3.7. As shown in the figure 2.3.6, the P1 and P2 pins are used to configure the PVI 3000-5300 inverter for the connection types of 208 V and 240 V AC outputs with or without neutral. When the inverter is set for the connection configurations with neutral, it can automatically distinguish the utility voltage and adjust the output AC voltage according the grid voltage.



**Note:** When connecting the PVI 3000-5300 inverter to the building / utility, the voltage **must** be compatible.



**Fig 2.3.6 Building/Utility configuration jumpers**



**Fig 2.3.7 Utility configurations**

**Connection of the AC wiring**

Use the following procedure to wire the AC cables.

Open the circuit breaker box and switch off the circuit breaker box that will be used to connect the inverter to the building.



**WARNING!**

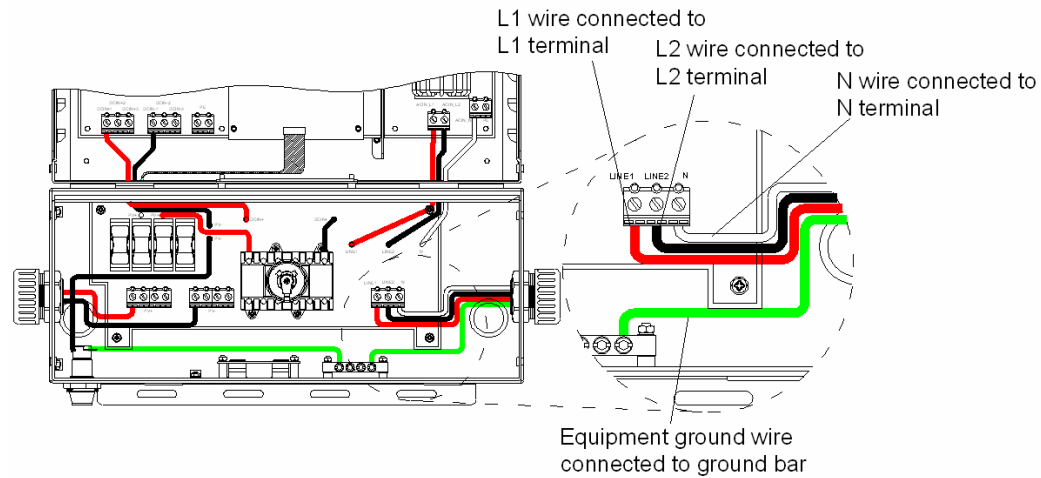
**Reconfirm that the circuit breaker to the grid/utility is switched OFF before connecting the power wires from the breaker to the inverter AC terminal block.**

Use #10 AWG to #6 AWG, 90 °C (194 °F) copper wire for all AC wiring connections to the PVI 3000/4000/5000/5300 inverters. You must choose the appropriate wire size based on NEC code requirements and we recommend designing not more than 2V drop (1%) at the most. Larger conductors will be needed for longer wire runs. For example, you may need to splice up to larger than #6AWG if a very long run such as greater than 200’ with a PVI 5300 to keep to the 2V (1%) drop.




**CAUTION!**

**To ensure that the total impedance of the grid plus the interconnection AC power cable shall be less than 0.18Ω for PVI 3000, 0.12Ω for PVI 4000, 0.10Ω for PVI 5000, 0.09Ω for PVI 5300. These values are based on a ~2VAC drop or ~1% AC loss.**



**Fig 2.3.8 AC Terminal Block for AC cable connections**

- Connect the AC equipment GND wire to the screw of the ground bar labeled 
- Connect the white N wire to the terminal labeled N of the AC terminal block.
- Connect the L1 wire to the terminal labeled Line1 of the AC terminal block.
- Connect the L2 wire to the terminal labeled Line2 of the AC terminal block.
- Tighten the screws with a torque of 15.6 in-lb (1.7Nm)




**WARNING!**

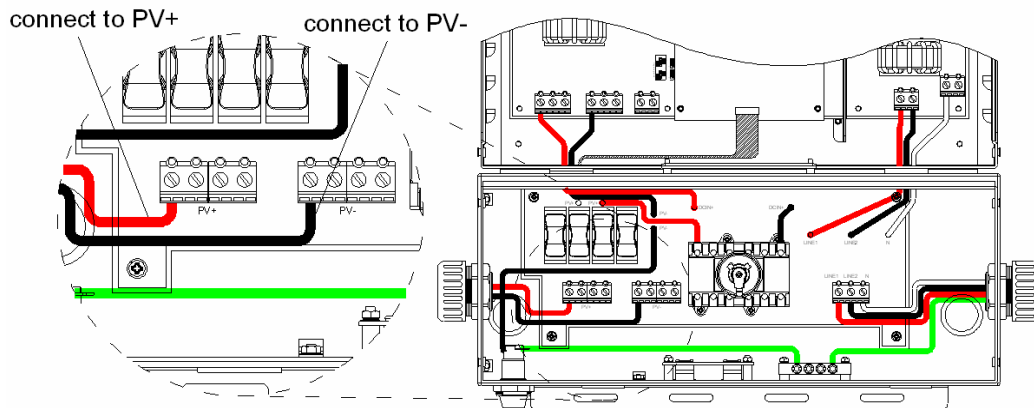
Each connection to a PVI 3000-5300 inverter must be installed with a separate circuit breaker with 20-30 amperes (depending on inverter model) maximum branch circuit over current protection in accordance with the National Electric Code, ANSI/NFPA 70. No other appliances may be connected to the circuit breaker.

- Reconfirm that all connections are correct as described above and all screws are properly tightened.

**Connection of the DC wiring**

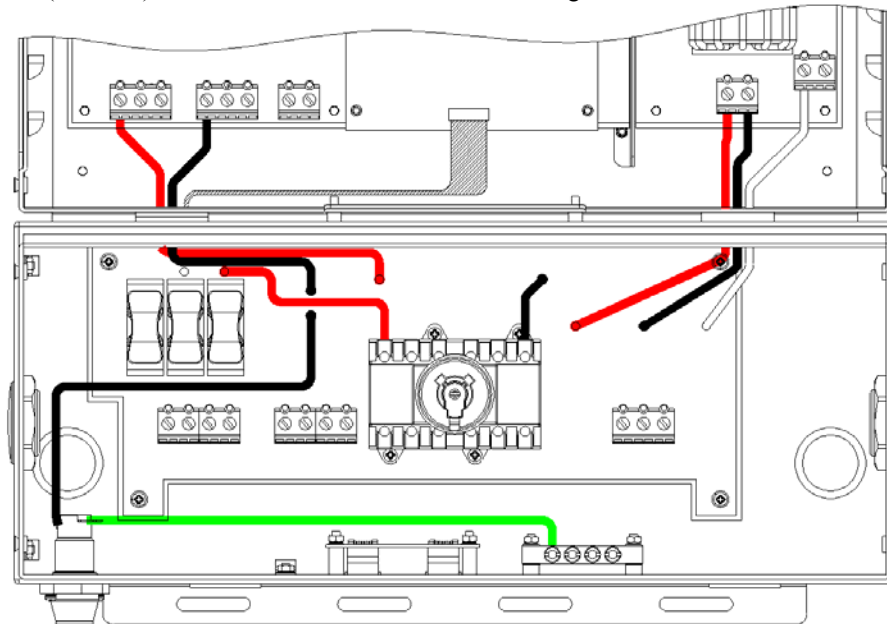
The wiring box of the PVI 3000-5300 inverter is designed with a pair of the DC terminal blocks which support up to four (4) independent PV strings to be connected in parallel in the wiring box and then feed into the inverter (or 3 in the case of the PVI 3000). The PVI 3000-5300 inverter is shipped with up to four (4) 15A, 600Vdc PV string fuses in the wiring box for the PV strings. However, the size of the PV string fuses shall be determined by the electrical ratings of the PV module and by UL and National Electrical Code (NEC) requirements. Please refer to Figure 5.2 for the replacement of the PV string fuses. 15A fuses are shipped standard with every inverter unless other values are specified at the time of order. 8, 10 and 12A values are also available from the factory.

There are two (2) terminals, labeled “+” and “-”, per PV string located in the wiring box used for the DC connections as shown in Figure 2.3.9 The DC equipment ground wire shall be connected to a screw on the ground bar labeled  in the wiring box of the PVI 3000-5300 inverter. All the screws shall be tightened with a torque of 15.6 in-lb (1.7Nm)



**Fig 2.3.9 DC terminal blocks for DC wiring connections**

The PVI 3000 is shipped with three (3) 15A, 600Vdc PV string fuses as shown in the Figure 2.3.10, below; therefore, the fourth pair of terminals (from left) shall not be used to connect to a PV string.



**Fig 2.3.10 PVI 3000 has three (3) PV string fuses (all other models have four (4))**




**CAUTION!**

PV arrays are energized when exposed to light. Use safe working practices when working on PV arrays.



**CAUTION!**

Polarities of each DC input voltage from a PV string shall be connected correctly to the “+” (positive) and “-” (negative) terminals of a pair respectively. The DC voltage must be less than 600V in any condition.

- The “+” wire of the DC input shall be connected to the terminal labeled “+” and the “-” wire of the DC input shall be connected to the terminal labeled “-”.
- Wire nuts shall not be used to join any wires together or to make any connections anywhere in the PV system except where acceptable by code. Wire nuts are a frequent cause of unreliable connections, resistive connections, and ground faults and are not allowed in certain applications by NEC.
- Connect the equipment ground wire to the screw of the ground bar labeled .
- Tighten the screws with a torque of 15.6 in-lb (1.7Nm)



**WARNING!**

Route the DC wires to the PVI 3000-5300 inverters away from any possible hazards that could damage to the wires (such as sharp corners, edges or near covers where wires could be pinched or crushed).

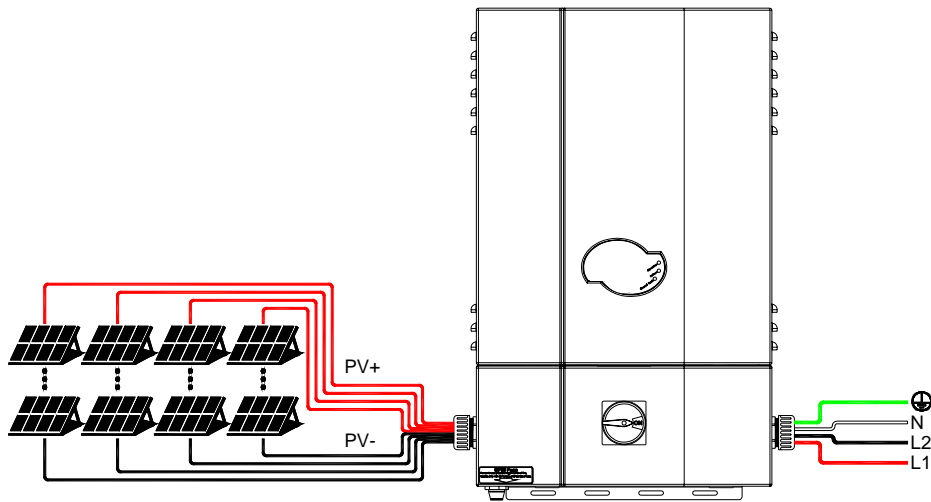


**WARNING!**

Hazardous voltage is still present on the inverter after disconnection of all PV DC inputs. Allow 5 minutes for the inverter to discharge the DC voltage completely.

- There are up to four (4) independent PV strings (4 pairs) can be connected to the PVI 4000-5300 inverter as shown in the figure 2.3.11. The PV strings will be connected in parallel in the wiring box. Therefore, these four (4) PV strings shall be the same in capacity (or at least the same total voltage).

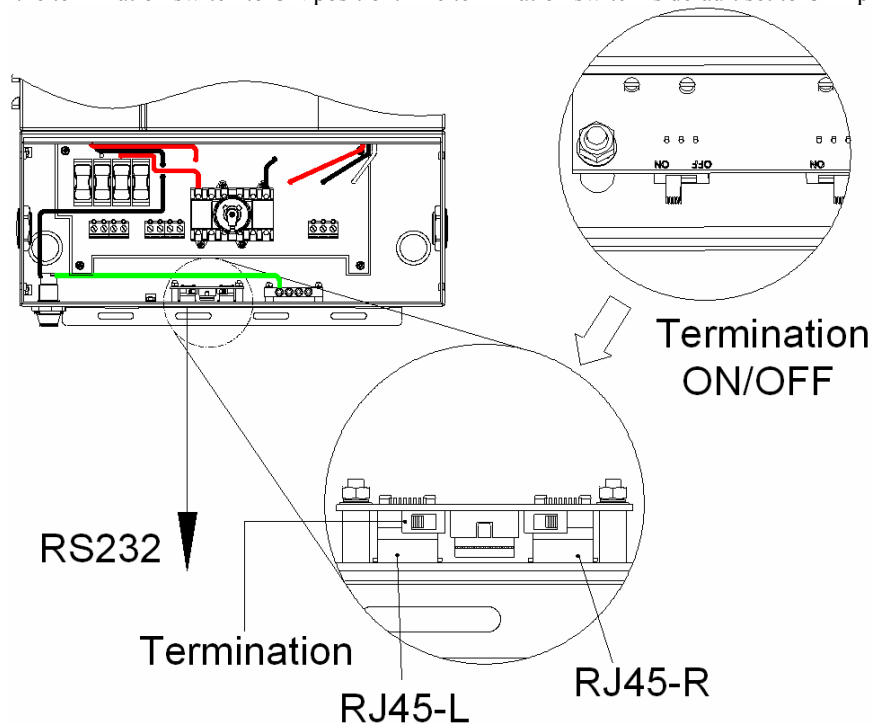




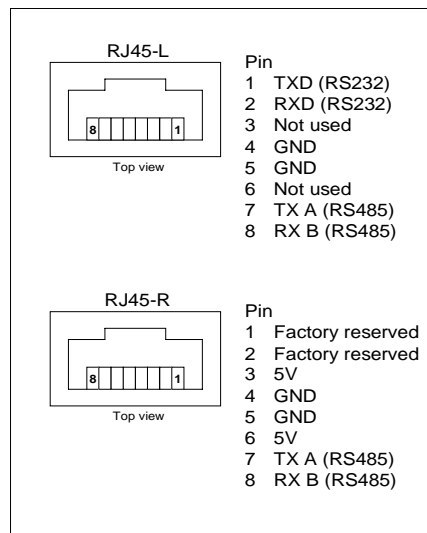
**Fig 2.3.11 PV- String connections and AC connections**

## 2.4 Connection of Communication wiring

The PVI 3000-5300 inverter supports two common data interface standards, RS-232 and RS-485 that will be used to communicate to the remote computer or communication gateway. Only one of the communication interfaces can work at a time. As shown in the Figure 2.4.4, there are two RJ-45 connectors, RJ45-R and RJ45-L that are located on the bottom of the wiring box. The pin numbers of the RJ-45 connectors and the corresponding signals are described in the Figure 2.4.2 below. If the RS485 is used as the external communication interface and the inverter is the last device in the RS485 loop, then the termination switch shall be put to ON position (shown in the figure 2.4.3). The installer needs to open the front cover of the wiring box to switch the termination switch to ON position. The termination switch is default set to OFF position.

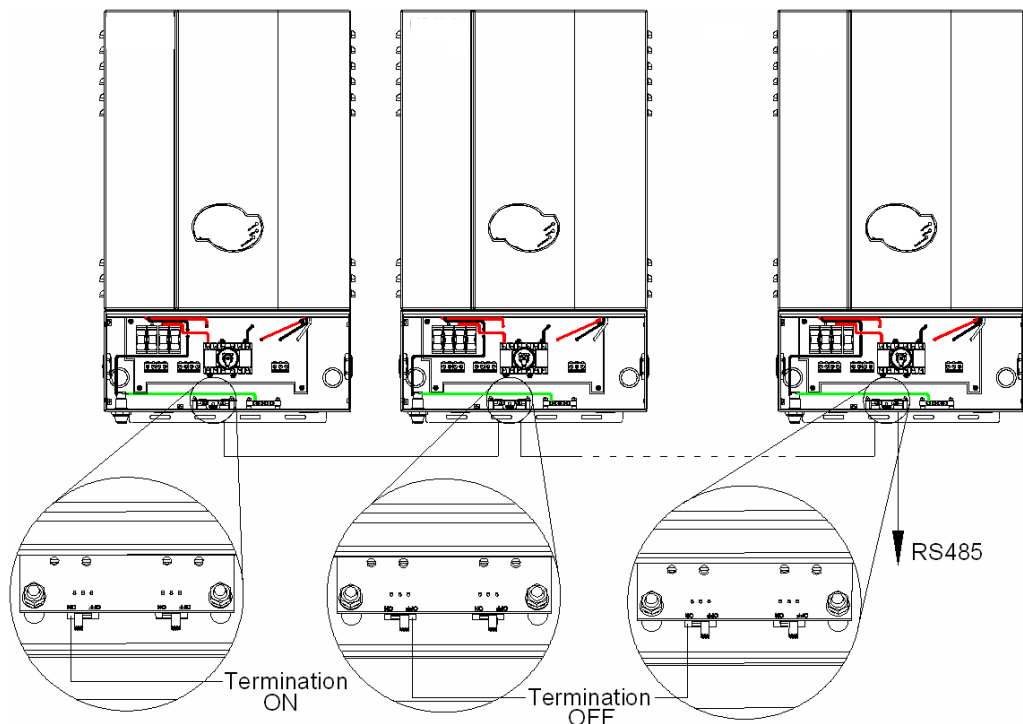


**Fig 2.4.1 positions of the communication ports and termination switches**



**Fig 2.4.2 RJ-45 Pinouts and Signals**

As shown in the Figure 2.4.2, the RS-232 signal pins, TXD and RXD, are in the RJ45-L connector. Therefore, only the RJ45-L can be used to connect to the remote PC or terminal when the RS-232 interface is selected. If RS-485 interface is selected, both RJ-45 connectors will be used for the daisy-chained / cascaded RS-485 connections shown in the Figure 2.4.3.



**Fig 2.4.3 RS-485 connection**

### Wiring inverters in parallel

PVI 3000-5300 inverters can be connected in parallel when more power is needed. In the parallel configuration, each inverter shall connect to its own PV array. It is not recommended to connect one PV array to more than one inverter. This may cause the inverter to work abnormally. The Figure 2.4.4 below shows the connections between inverters and PV arrays in parallel configuration.

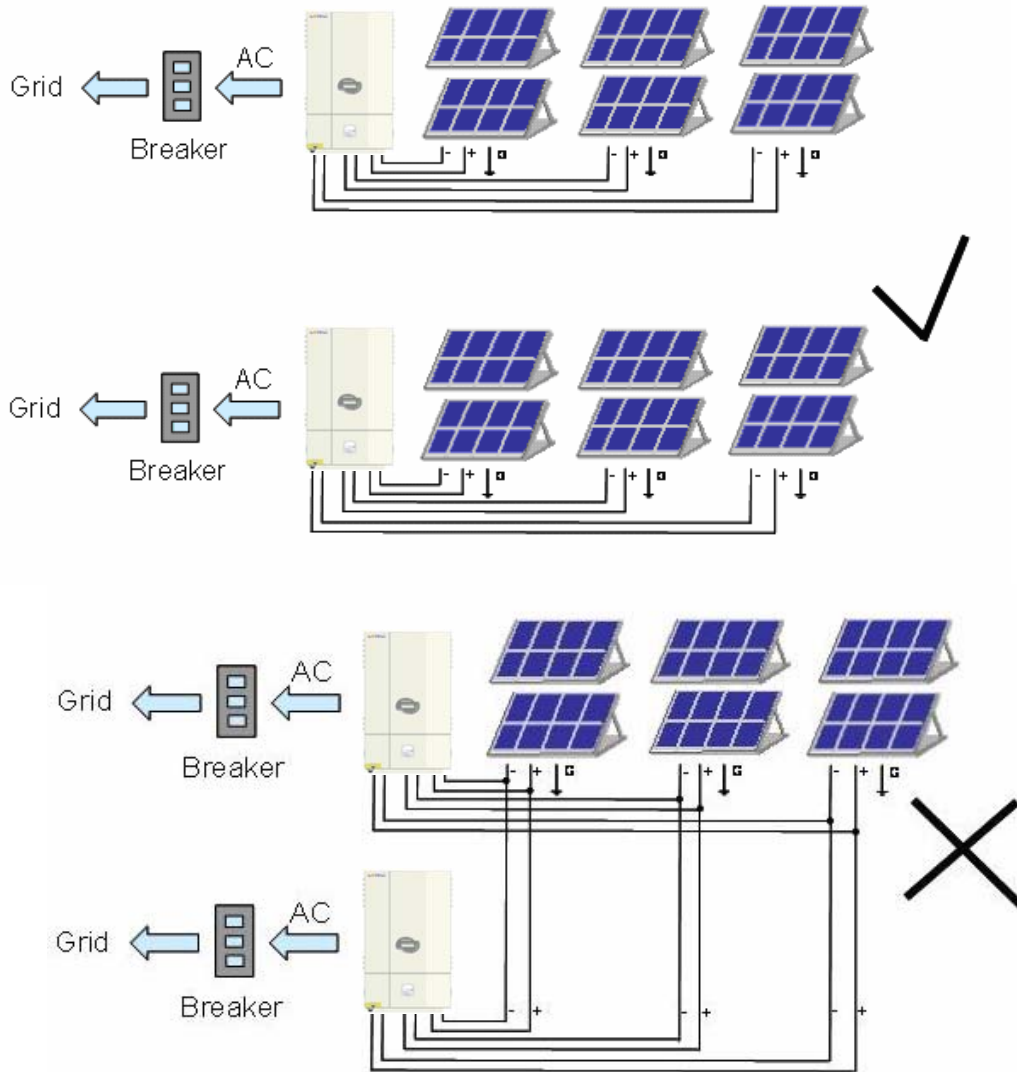


Fig 2.4.4 Parallel configuration of inverter

## 3 Commissioning the Inverter and PV System

The inverter is mounted, all connections are made and you are ready to power it up.



**NOTE:** Make sure all tools; parts, etc. are removed from the vicinity of the inverter before turning on.



**WARNING:** Make a final check for correctness of all AC and DC wiring to the inverter and in the system.



**NOTE:** With the PV modules connected and inverter disconnects still off, it is a good precaution to check PV polarity once more simply by carefully using a 1000V, DC rated digital volt meter and probing the positive (+) and negative (-) PV connections on the terminal blocks in the wiring box.

#### Turning on the inverter:

- Turn on the dedicated 2-pole circuit 240/208VAC circuit breaker on the home/building electrical panel
- Turn on the AC disconnect (if the system is equipped with one)
- Turn on the DC disconnect on the inverter.
- Watch the LED indicators for initialization (all three LEDs on) and LCD messages.
- Watch for blinking green LED and LCD messages indicating 5 minute connect to grid time and following this time, the inverter will be on-line and beginning to feed power into the AC circuit, the inverter is operating normally
- Last, look for a steady green LED indicating the inverter has stabilized at Maximum Power Point

See LCD section (4) of manual for detailed description of messages and indications.

#### Operation:

The control electronics will be active as soon as DC (PV) voltage reaches 200VDC. The inverter will go on-line with the utility/building grid when the DC voltage first exceeds 235VDC (strike voltage). Next, the inverter will load the array, bringing the DC voltage down from 235VDC to no less than 200VDC.

Once there is enough PV power at 200VDC to back feed AC power switching will automatically feed power to the grid. (The inverter will always wait 5 minutes after being turned on before going into grid-feed mode).

Because the inverter goes completely off line at night or in dark conditions when no power can be produced, the standby losses are less than 0.5 Watt, adding additional energy production annually compared to some competitor's inverter designs that remain on all the time.

Operating states, GFDI status and error indications shown by the LED indicators, and data, mode and error codes are shown by the LCD display which are described in chapter 4, "Power, GFDI, Error LED Indicators and LCD Display".

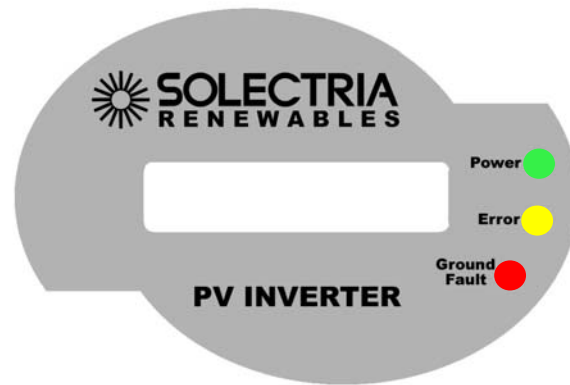
## 4 Power, Ground Fault, Error LED Indicators and LCD Display

The inverter operates automatically without the need for user interaction or maintenance.

The PVI 3000-5300 automatically starts feeding AC power into the grid every morning as the sun rises, as soon as sufficient DC voltage and PV power is available. The inverter microcontroller runs through various checks before going online with the grid and feeding power into the grid.

## 4.1 Power, Ground Fault and Error LED Indicators

There are three light-emitting diodes (LEDs) mounted on the front (center) of the inverter to show the operating condition of the inverter (to the right of the LCD display).



**Fig. 4.1: Power, Error, and Ground Fault Indicator LEDs and LCD Display**

The green LED "Power" shows the current operating condition.

The yellow LED "Error" indicates whether there is an internal or external fault present and whether the AC grid back-feed has been interrupted.

The red LED "Ground Fault" shows if a ground fault is present. (If there is any ground current measured the value can be shown on the display, scrolling through the display is necessary to locate the Ground Fault current value)

Description of LED symbols used to indicate LED status in this manual

○ : LED ON

● : LED OFF

X : Inconsequential

☀ : LED ON/OFF 0.9/0.1 Sec

⊗ : LED ON/OFF 0.1/0.9Sec

**LED Indication Table**

LED indicators	Operating status	Description
Green Yellow Red	☐ ☐ ☐	Initialization The inverter is in initialization mode.
Green Yellow Red	☐ ● ●	System Check mode The inverter is in System Check mode.
Green Yellow Red	☐ ● ●	Monitor mode The inverter is in Monitoring mode.
Green Yellow Red	○ x ●	Grid/MPP mode The inverter is in Grid Feeding mode.
Green Yellow Red	● ○ x	Fault mode The inverter is in Fault mode.
Green Yellow Red	○ ○ x	Idle mode The inverter is in Idle mode.
Green Yellow Red	● ● ●	Night Time There is no DC power coming from PV array. System is powered off.
Green Yellow Red	● ● ○	Ground Fault Ground fault detected.
Green Yellow Red	x ☼ ●	Warning Warning is detected.
Green Yellow Red	☼ x ●	De-rating Power de-rating function.

## 4.2 The LCD Display

The PVI 3000-5300 inverter is supplied ready to operate so there are no settings, which need to be made by the user for fully automatic feeding of power into the grid. The device comes standard with an LCD display on which various data can be read. All indicated data is only an indication and has tolerances of up to ± 5%.

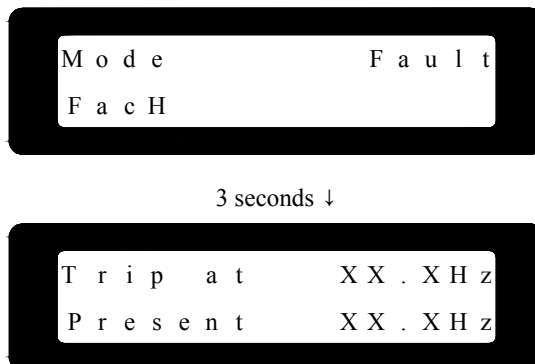
The PVI 3000-5300 inverter has a 16 x 2 LCD to show the operating status, input/output data, and error messages. As long as the DC input voltage is above the minimum MPP voltage (200VDC), the LCD continues to display the information following the process flow illustrated in the Figure 4.2.1.

The process flow may follow the operating mode, fault mode, or idle mode. The operating mode is when the system goes from power-on to system check, monitoring, and then grid feeding mode without any fault condition detected. The inverter is should work following the operating mode and eventually feeds the power to the grid. During the system check and monitoring mode, if a fault condition that could be cleared automatically is detected, then the system will go into the fault mode that the system could return to the operating mode once the fault condition goes away. One obvious example is that an “island” condition is detected due to the grid going off and then back on later, the fault condition is cleared when the power returns. If a fault cannot cleared on its own, then the system will enter the idle mode and will need a service person to clear the fault and reset the system. These three modes are illustrated in the Figure 4.2.1.

The messages for the fault mode are as follows. It shows the fault mode, serial number of the inverter, software versions of the sequential and current controllers and then the error messages which are listed in the Error Message Table on section 4.1.



There are several error messages that show the detailed conditions that cause the system to go into the fault mode, such as the messages shown below that show that the frequency of the AC grid is too high. After three (3) seconds, the message shows the present frequency and the frequency that caused the system to go into the fault mode.



The messages below show that the frequency is too low and then, 3 seconds later, the present frequency and the frequency causing the system to go into the fault mode.

```

M o d e           F a u l t
F a c L
  
```

3 seconds ↓

```

T r i p   a t       X X . X H z
P r e s e n t       X X . X H z
  
```

The message below shows that the AC voltage is too high and next it displays the present AC voltage on the grid and voltage causing the system to go into the fault mode.

```

M o d e           F a u l t
V a c H
  
```

3 seconds ↓

```

T r i p   a t       X X X . X V
P r e s e n t       X X X . X V
  
```

The message below shows that the AC voltage is too low....

```

M o d e           F a u l t
V a c L
  
```

3 seconds ↓

```

T r i p   a t       X X X . X V
P r e s e n t       X X X . X V
  
```

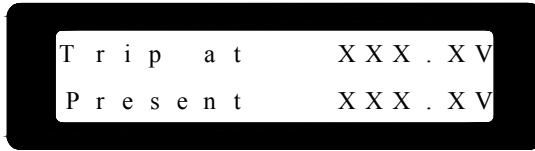
The message below shows the PV DC voltage is too high....

```

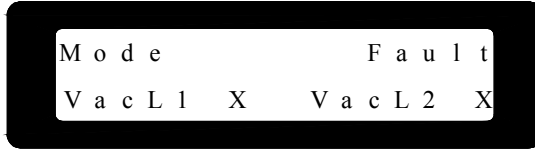
M o d e           F a u l t
V p v H
  
```

3 seconds ↓



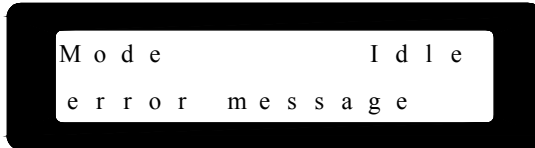
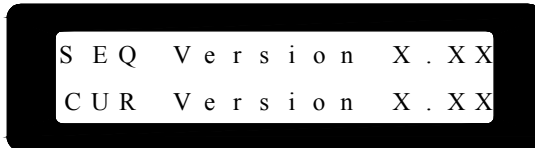
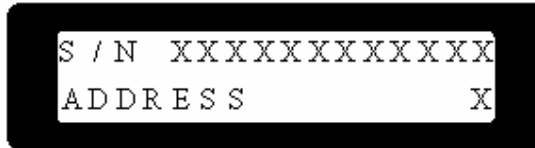


The following message presents that the AC line1 and/or line2 voltage (refer to the neutral) is/are too high (H) or too low (L)....



X: H or L

The messages for the idle mode are as follows. It shows the operating mode, serial number of the inverter, software versions of the sequential and current controllers and then the error messages which are listed in the Error Message Table on section 4.1.



The following figures explain how the display works in the operating mode.

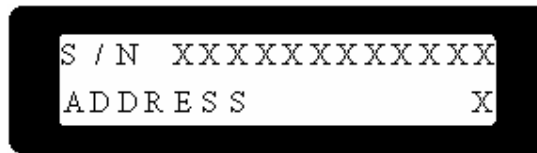
When the DC input voltage goes above the minimum MPP voltage, the inverter is powered up and will show the company name and model name (PVI 4000 in this example) on the LCD as shown below.



After 3 seconds, software versions of two embedded CPU's, Sequential and Current controllers, will be displayed on the LCD. Next, the serial number of the inverter and the address for the RS-485 communication are displayed.

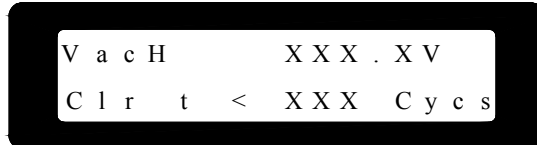


3 seconds ↓

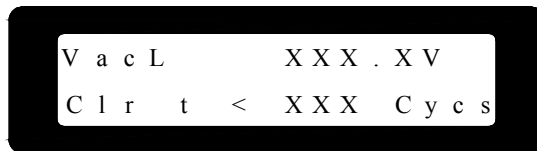


3 seconds ↓

Three (3) seconds later, it displays the setting of the VacH which is the phase-to-phase (rms) high threshold voltage setting at which point the inverter disconnects itself from the grid when abnormally high phase-to-phase AC voltage is detected. Also, the setting of the clearing time which is the total duration of time to disconnect the output from the AC grid is displayed. The clearing time is the summation of the de-bounce time and the hardware delay time. This delay is necessary to avoid nuisance trips. After the settings of the VacH and its clearing time, the settings of the VacL and its clearing time will be displayed for three (3) seconds.

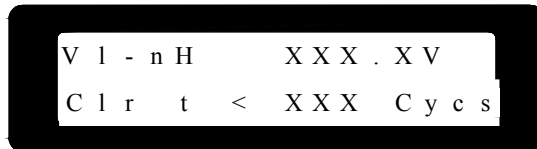


3 seconds ↓

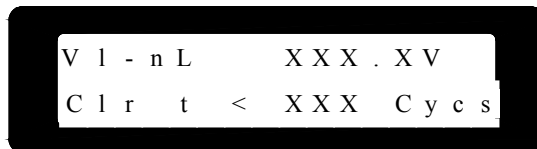


3 seconds ↓

Then the settings of the VI-nH and its clearing time will be displayed. The VI-nH setting is the phase-to-neutral (rms) high threshold voltage setting at which point the inverter disconnects its output from the AC power grid when abnormally high phase-to-neutral AC voltage is detected. After the setting of the VI-nH is displayed, the setting of the VI-nL will be displayed for 3 seconds.

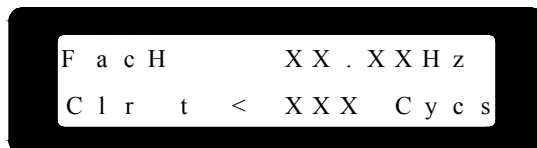


3 seconds ↓

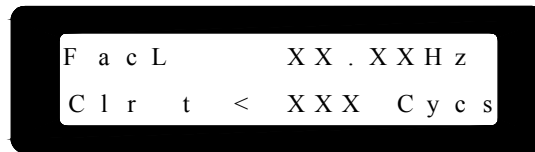


3 seconds ↓

Then the high and low threshold settings of the AC frequency and the clearing time will be shown for three (3) seconds. When the AC frequency reaches the high or low threshold setting, the inverter will disconnect its output from the AC grid.

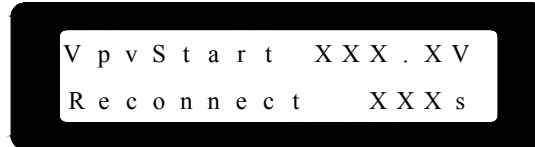


3 seconds ↓



3 seconds ↓

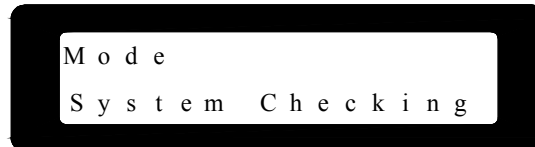
Then the setting of the re-connection time will be displayed. The re-connection time is the duration of delay time for the inverter to re-connect to the grid after the fault(s) is(are) cleared.



3 seconds ↓

Waiting Mode Display

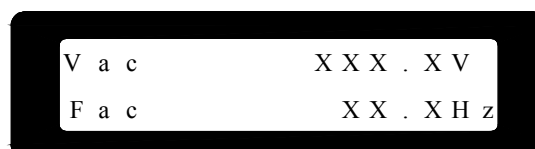
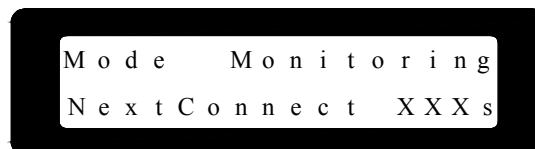
After the basic information of the inverter is displayed, the system enters the System Check mode which is indicated on the LCD.



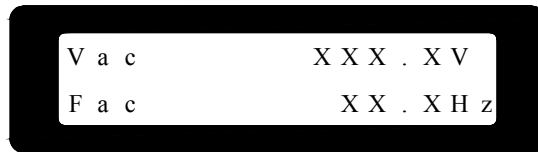
During system checking, if the grid is not connected to the inverter, then the following message will be shown on the LCD and the system will remain at this step.



Once system check is done, the inverter goes into the monitoring mode. If all data needed for grid feeding is in the acceptable range, the system will keep monitoring this data for a period of time. The following information tells users that the system will go into the grid feeding mode in XXX seconds and then show the measured data of the DC input voltages and the existing voltage and frequency on the grid side.



During the monitoring mode, if DC input voltages fall under the threshold value, the system stays in this mode and shows the information as follows. The system will still keep measuring the parameters of both DC and AC and display on the LCD.

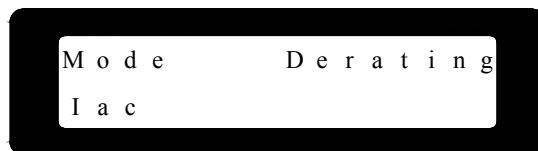
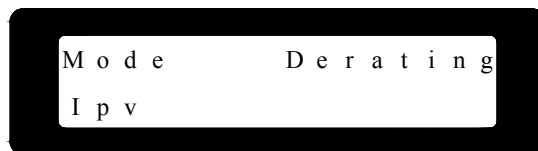
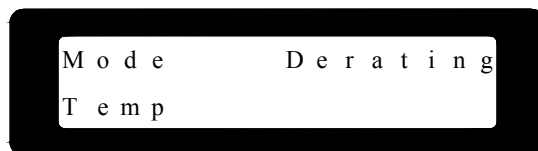


After the system enters the grid feeding mode, it will show the following information in order and repeat this until the system goes to another operating mode.

The first screen shows the current operation mode.



There are four possible de-rating indications that can be shown if power de-rating is detected. Only one potential source that causes de-rating can be detected at a time. Therefore, only one of the following messages will be displayed if power de-rating occurs. When Temp message is presented, the power de-rating is caused by the over temperature. The Ipv message shows that the power de-rating is caused by restricting the DC input current to the maximum limit. The Iac and Pac messages illustrate that the power de-rating is caused due to limiting of the maximum output AC current and power.



The next messages are the up-to-minute data of the DC input voltages and the AC output voltage. The first two messages are for the PV array and the other two messages are for the AC output power. Vpv is the incoming voltages from the PV array. Wpv is the incoming power of the PV array in Watts. Vac, Pac, Iac, and Fac are the voltage, power, current, and frequency that the inverter feeds to the grid.

```
V p v      X X X V
W p v      X X X X W
```

```
V a c      X X X . X V
P a c      X X X X W
```

```
F a c      X X . X H z
I a c      X X . X A
```

The next message shows the cumulative energy in kWh and period of time in hours for which the inverter has been delivering power to the grid from the date the inverter was installed and has been operating.

```
E a c  X X X X X X . X k W h
H      X X X H r
```

There are three possible warning messages that may be displayed with different failures. When EEPROM message is displayed, the system is unable to access the EEPROM. The COMM message means a failure of the communication function. The FAN BLOCK message shows that the fan has stopped running. These warnings could appear one after the other.

```
W a r n i n g
E E P R O M
```

```
W a r n i n g
C O M M
```

```
W a r n i n g
F A N B L O C K
```

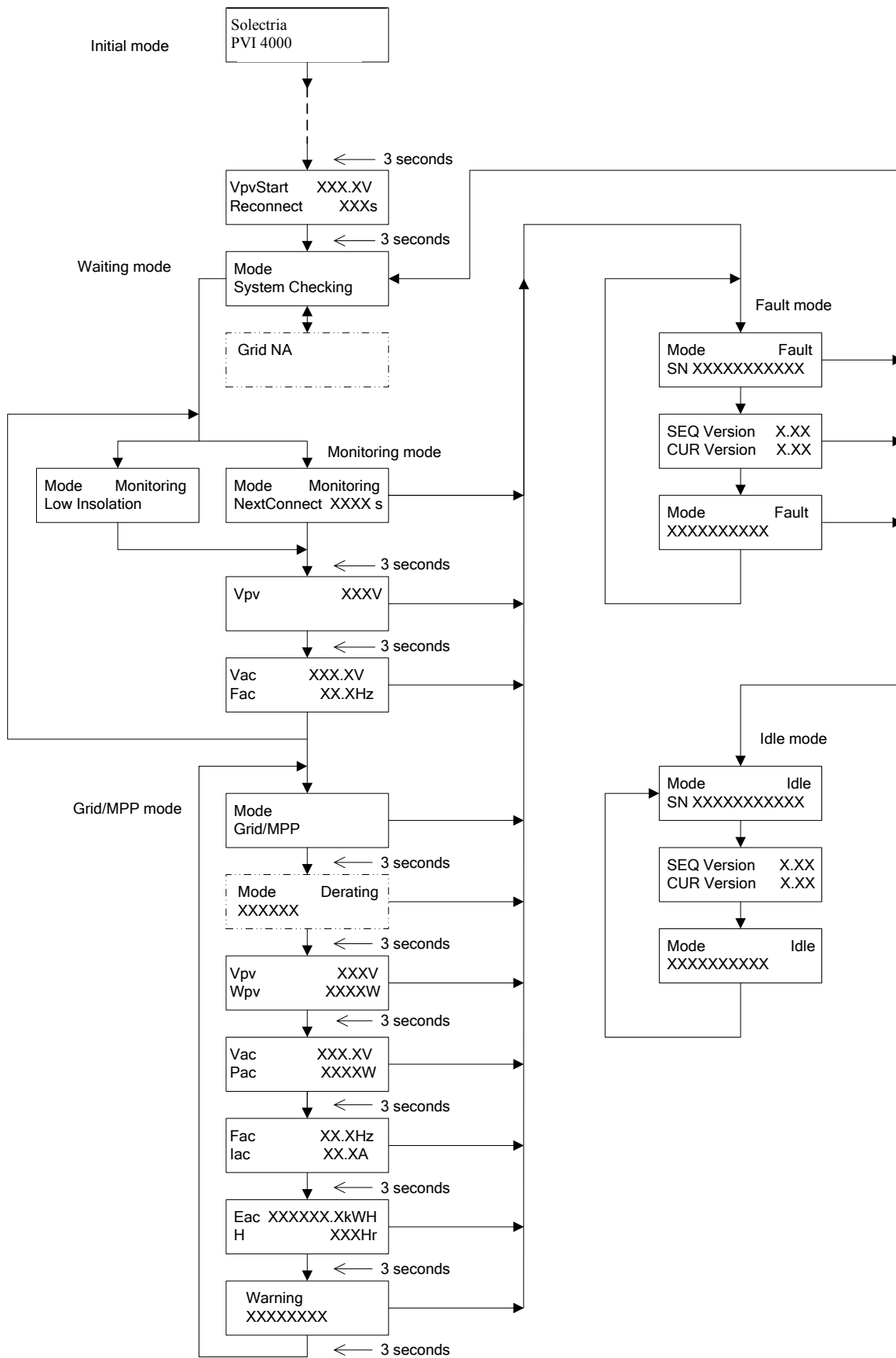


Fig 4.2.1 PVI 3000-5300 inverter LCD display flow-chart

## 5 Troubleshooting

### Diagnosis and analysing data

#### Identifying and resolving faults

The PVI 3000-5300 is fitted with a self-diagnostic system, which can recognise a majority of possible faults and show these on the display. This allows the operator to rapidly identify possible problems in the solar inverter or system. Please refer to the LCD section (4) for a thorough explanation of fault codes, modes, etc. These indicate both internal errors and external faults.

#### Ground Fault:

If a significant ground fault occurs in the PV array or wiring, the GFDI fuse (located on the wiring/connector panel) may be blown. If it is, determine and repair ground fault and replace fuse with Bussmann KLKD1 (1 Amp, 600VDC).

If the GFDI detects a ground fault current larger than 0.8A, the error LED will light and the fault will be displayed. In addition to this, the GFDI current value can be read in the display.

#### Weak Sunlight Condition:

Operation in weak sunlight, (for example early in the morning, when overcast or when snow is covering most or all of the PV array) can cause the inverter to go through a cycle of trying to start and restart several times. This can occur if the array reached 235V (strike voltage) but there is nearly no power available, for example in the very early morning low light or cloudy weather. If in doubt, wait for stronger sun.

### Explanations of Error Messages

In the event of a fault, the inverter will stop feeding the AC voltage to the building/utility and display the error message on the LCD. Qualified service personnel shall do the analysis, measurement, and debug the system if needed according to the error message in order to resume normal operation. It is recommended to analyse the fault condition(s) by referring to the table below and then remove the fault condition(s) in order to return the inverter to normal and continue to feed AC voltage to the utility steadily. Please contact Solectria Renewables if the same error message is persistent.

**Error Message Table**

Error Message	Description
GridNA	No AC voltage is detected.
Drift Fac	Islanding is detected.
VacH	The AC voltage of utility is above the upper limit.
VacL	The AC voltage of mains utility is below the lower limit.
FacH	The frequency of AC voltage of the utility is above the upper limit.
FacL	The frequency of AC voltage of the utility is below the lower limit.
VpvH	The DC voltage of PV array is above the upper limit.
Imax_AC	Over current on the AC side.
InvTempMax	The internal temperature of the inverter exceeded the safe operating limit.
Relay Open Relay Close	Relay test failed.
VacL1 H	The voltage between L1 and neutral is over the upper limit.
VacL1 L	The voltage between L1 and neutral is under the lower limit.
VacL2 H	The voltage between L2 and neutral is over the upper limit.
VacL2 L	The voltage between L2 and neutral is under the lower limit.

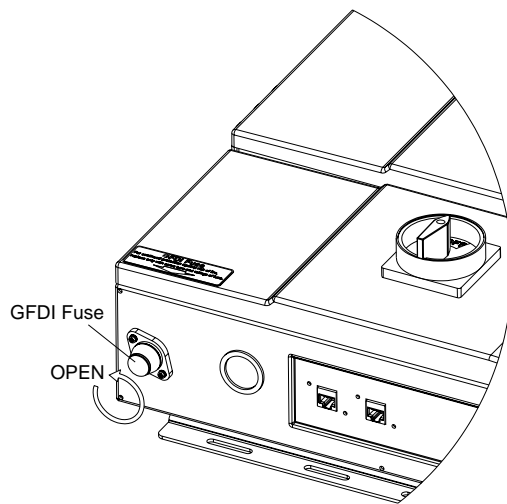
MOV Fault, AC	High voltage protection function failed on the AC side.
MOV Fault, DC	High voltage protection function failed on the DC side.
GFDI	The GFDI Fuse is open or blown.
VacL-N High	Vrms of L-N is above the upper limit.
VacL-N Low	Vrms of L-N is below the lower limit.
DCInjectCurH	Too much DC current injected into the AC grid is detected.
VdebusH	Internal DC bus voltage is above the upper limit.
Internal COMM	Internal communication failed.
Watchdog	Internal watchdog function triggered.
Idc Test	The DC injection current monitoring function failed.
Offset	Offset check for grid monitoring failed.
Temp. Sensor	The internal temperature sensor failed.
RAM Test	Memory failed
EEPROM Test	EEPROM test failed.
System Error	The system failed.
Version Error	The firmware version is not correct.
CPU Delta Fac CPU Delta Vac CPU Delta GFDI CPU Delta Idc	Internal measurement comparison error or defective hardware
IpvH	Over current on the DC side
Driver Fault	Driver circuit or power device failed
CalDataError	Calibration data is out of range
CalDataLoss	Calibration data is lost.
Ibuck Over	Internal converter over current

## Maintenance:

### Replacing the GFDI Fuse

Remove the cap of the GFDI fuse holder to open and then replace the GFDI fuse with the same type and rating (600VDC, 1A). Before replacement of the fuse, you must switch off the DC switch and the AC breaker and wait for at least 5 minutes for system to discharge.





1. Turn OFF all AC and DC switches and/or breakers
2. Wait for at least 5 minutes
3. Exchange the fuses
4. Turn ON all AC and DC switches and/or breakers

**Fig 5.1 Open the cap of the GFDI fuse holder**

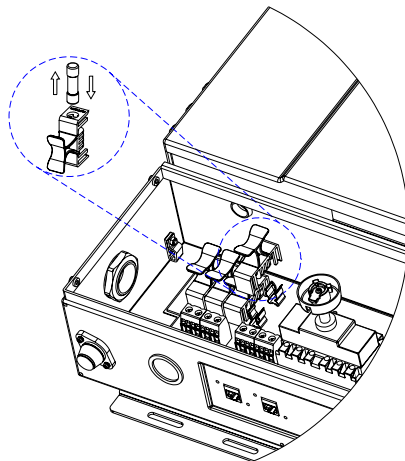


**WARNING!**

For continued protection against risk of fire, replace only with the same type and ratings of fuse (600 VDC, 1 A)!

### Replacing of the PV String Fuses

The inverter is shipped with four (4) 15A, 600Vdc PV string fuses for PV strings (or three for PVI 3000). However, the size of the PV string fuse is determined by the electrical ratings of the PV module and by UL and National Electrical Code (NEC) requirements. The minimum size of the PV string fuse is calculated using the short circuit current rating (Isc) of the PV module. The NEC requires that the fuse be sized for a minimum of 1.56 times the Isc of the PV module used in the system and not over the module's fuse rating. Please be sure to consult with the PV module manufacturer for appropriate PV string fuse rating.



1. Turn OFF all AC and DC switches and/or breaker.
2. Wait for at least 5 minutes.
3. Remove the cover of the wiring box by following the steps described in section 2.3.
4. Replace the fuses as shown in the figure 5.4.2.1.
5. Put the cover of the wiring box back and fasten the screws.
6. Turn ON all AC and DC switches and/or breakers.

**Fig 5.2 Replacement of the PV string fuses**



**WARNING!**

PV arrays is always energized when exposed to light therefore hazardous voltage is still present on the terminal blocks and the PV string fuse holders even the DC switch is switched OFF. Please cover the PV arrays with opaque (dark) materials during PV string fuse replacement.

**CAUTION!**

The string fuse size must not be greater than the maximum fuse size rating of the PV module provided on the PV module manufacturer data sheet. If no maximum fuse size is indicated, please contact the PV module manufacturer.

## 6 Product Warranty & RMA Policy

### 6.1 Warranty Policy

The Solectria Renewables Warranty Policy is stated below.

**Solectria Renewables Warranty Coverage:**

Solectria Renewables Limited Warranties are provided by Solectria Renewables, LLC. ("Solectria Renewables") and cover defects in workmanship and materials.

**Duration of a Solectria Renewables Warranty Period:**

The warranty period is 120 months from the date of purchase of the PVI3000/4000/5000/5300 by the end user or 124 months after the delivery date from Solectria Renewables to installer, dealer, distributor (merchant) whichever is shorter.

If Solectria Renewables repairs or replaces a product, its warranty continues for the remaining portion of the original Warranty Period or 90 days from the date of the return shipment to the customer, whichever is greater.

All warranties are null and void if full payment for products and associated shipping are not received in full and in a timely manner by Solectria Renewables.

Please contact Solectria Renewables Customer Service for further details on other products.

**What will Solectria Renewables do?**

Solectria Renewables will, at its option, repair or replace the defective product free of charge, provided that you notify Solectria Renewables of the product defect within the Warranty Period for your product, and provided that Solectria Renewables, through inspection, establishes the existence of such a defect and that it is covered by the Limited Warranty.

Solectria Renewables will, at its option, use new and/or reconditioned parts in performing warranty repair and building replacement products. Solectria Renewables reserves the right to use parts or products of original or improved design in the repair or replacement. All replaced products and all parts removed from repaired products become the property of Solectria Renewables.

Solectria Renewables will attempt to repair the unit within a reasonable time period (there is no reimbursement for lost energy production.)

Solectria Renewables covers both parts and labor necessary to repair the product, and return shipment to the customer via a Solectria Renewables-selected non-expedited surface freight within the contiguous United States and Canada. Alaska and Hawaii and the Rest of The World are excluded. Contact Solectria Renewables customer service for details on freight policy for return shipments outside of the contiguous United States and Canada.

**Obtaining Service:**

If your product requires troubleshooting or warranty service, contact your merchant. If you are unable to contact your merchant, or the merchant is unable to provide service, contact Solectria Renewables directly at the number listed on the website in the customer service section for your product.

Direct returns may be performed according to the Solectria Renewables Return Material Authorization Policy.

In any warranty claim, dated proof of purchase must accompany the product and the product must not have been disassembled or modified without prior written authorization by Solectria Renewables.

Proof of purchase may be in any one of the following forms:

- The dated purchase receipt from the original purchase of the product at point of sale to the end user, or
- The dated merchant invoice or purchase receipt showing original equipment manufacturer (OEM) status, or
- The dated invoice or purchase receipt showing the product exchanged under warranty.

**What does the Solectria Renewables warranty not cover?**

Solectria Renewables Limited Warranties do not cover normal wear and tear of the product or costs related to the removal, installation, or troubleshooting of the customer's electrical systems. These warranties do not apply to and Solectria Renewables will not be responsible for any defect in or damage to:

- a) The product if it has been misused, neglected, improperly installed, physically damaged or altered, either internally or externally, or damaged from improper use or use in an unsuitable environment;
- b) The product if it has been subjected to fire, water, generalized corrosion, biological infestations, acts of God or input voltage that creates operating conditions beyond the maximum or minimum limits listed in the Solectria Renewables product specifications including high input voltage from generators and lightningstrikes;
- c) The product if repairs have been done to it other than by Solectria Renewables;
- d) The product if it is used as a component part of a product expressly warranted by another manufacturer;
- e) The product if its original identification (trademark, serial number) markings have been defaced, altered, or removed;
- f) The product if it has been damaged in shipping
- g) Any installation and operation beyond the scope covered by relevant safety regulations (UL1741, NEC, etc.);

**DISCLAIMER**

**SOLECTRIA RENEWABLES LIMITED WARRANTIES ARE THE SOLE AND EXCLUSIVE WARRANTY PROVIDED BY SOLECTRIA RENEWABLES IN CONNECTION WITH YOUR SOLECTRIA RENEWABLES PRODUCT AND ARE, WHERE PERMITTED BY LAW, IN LIEU OF ALL OTHER WARRANTIES, CONDITIONS, GUARANTEES, REPRESENTATIONS, OBLIGATIONS AND LIABILITIES, EXPRESS OR IMPLIED, STATUTORY OR OTHERWISE IN CONNECTION WITH THE PRODUCT, HOWEVER ARISING (WHETHER BY CONTRACT, TORT, NEGLIGENCE, PRINCIPLES OF MANUFACTURER'S LIABILITY, OPERATION OF LAW, CONDUCT, STATEMENT OR OTHERWISE), INCLUDING WITHOUT RESTRICTION ANY IMPLIED WARRANTY OR CONDITION OF QUALITY, MERCHANTABILITY OR FITNESS FOR A PARTICULAR PURPOSE. ANY IMPLIED WARRANTY OF MERCHANTABILITY OR FITNESS FOR A PARTICULAR PURPOSE TO THE EXTENT REQUIRED UNDER APPLICABLE LAW TO APPLY TO THE PRODUCT SHALL BE LIMITED IN DURATION TO THE PERIOD STIPULATED UNDER THIS LIMITED WARRANTY.**

**IN NO EVENT WILL SOLECTRIA RENEWABLES, LLC, INCLUDING ITS SUPPLIERS, MANUFACTURERS, VENDORS, SUBCONTRACTORS, DISTRIBUTORS, DEALERS AND ANY OTHER AFFILIATES BE LIABLE FOR ANY SPECIAL, DIRECT, INDIRECT, INCIDENTAL OR CONSEQUENTIAL DAMAGES, LOSSES, COSTS OR EXPENSES HOWEVER ARISING WHETHER IN CONTRACT OR TORT INCLUDING WITHOUT RESTRICTION ANY ECONOMIC LOSSES OF ANY KIND, ANY LOSS OR DAMAGE TO PROPERTY, ANY PERSONAL INJURY, ANY DAMAGE OR INJURY ARISING FROM OR AS A RESULT OF ANY USE, MISUSE OR ABUSE, OR THE (IN-) CORRECT INSTALLATION, INTEGRATION OR OPERATION OF THE PRODUCT.**

Solectria Renewables neither assumes nor authorizes any other person to assume for it any other liability in connection with the repair or replacement of the Product.

**Exclusions of the Policy:**

If your product is a consumer product, federal law does not allow an exclusion of implied warranties. To the extent you are entitled to implied warranties under federal law, to the extent permitted by applicable law they are limited to the duration of this Limited Warranty. Some states and provinces do not allow limitations or exclusions on implied warranties or on the duration of an implied warranty or on the limitation or exclusion of incidental or consequential damages, so the above limitation(s) or exclusion(s) may not apply to you. This Limited Warranty gives you specific legal rights. You may have other rights, which may vary from state to state or province to province.

**WITHOUT LIMITING THE GENERALITY OF THE FOREGOING, UNLESS SPECIFICALLY AGREED TO BY IT IN WRITING, SOLECTRIA RENEWABLES**

**(a) MAKES NO WARRANTY AS TO THE ACCURACY, SUFFICIENCY OR SUITABILITY OF ANY TECHNICAL OR OTHER INFORMATION PROVIDED IN MANUALS OR OTHER DOCUMENTATION PROVIDED BY IT IN CONNECTION WITH THE PRODUCT; AND**

**(b) ASSUMES NO RESPONSIBILITY OR LIABILITY FOR LOSSES, DAMAGES, COSTS OR EXPENSES, WHETHER SPECIAL, DIRECT, INDIRECT, CONSEQUENTIAL OR INCIDENTAL, WHICH MIGHT ARISE OUT OF THE USE OF SUCH INFORMATION.**

**THE USE OF ANY SUCH INFORMATION WILL BE ENTIRELY AT THE USER'S RISK.**

**WARNING: LIMITATIONS ON USE**

Please refer to your product user manual for limitations on uses of the product. Specifically, please note that Solectria Renewables products are not intended for use in connection with life support systems and Solectria Renewables makes no warranty or representation in connection with any use of the product for such purposes.

Please review our Return Merchandise Authorization Policy for returning product to Solectria Renewables.

## 6.2 Return Material Authorization Policy

Please review our Return Merchandise Authorization Policy below after reviewing our Solectria Renewables Warranty Policy.

**Obtaining a required, Return Material Authorization:**

Before returning a product directly to Solectria Renewables you must obtain a Return Material Authorization (RMA) number and the correct factory "Ship To" address. Products must also be shipped prepaid. Product shipments will be refused and returned at your expense if they are unauthorized, returned without an RMA number clearly marked on the outside of the shipping box, if they are shipped collect, or if they are shipped to the wrong location.

**Information Solectria Renewables needs when you are obtaining service:**

- 1) The model names and serial number of your product
- 2) Information about the installation and use of the unit
- 3) Information about the failure and/or reason for the return
- 4) A copy of your dated proof of purchase.

**Preparing the product for shipping (an RMA form will be sent to you):**

- 1) Package the unit safely, preferably using the original box and packing materials. Please ensure that your product is shipped fully insured in the original packaging or equivalent. This warranty will not apply where the product is damaged due to improper packaging.
- 2) Include the following:
  - a. The RMA number supplied by Solectria Renewables, LLC clearly marked on the outside of the box
  - b. A return address to which the unit can be shipped. Post office boxes are not acceptable.
  - c. A contact telephone number where you can be reached during work hours.
  - d. A brief description of the problem.

Ship the unit prepaid to the address provided by your Solectria Renewables customer service representative.

**Returning a product from outside of the USA or Canada:**

In addition to the above, you **MUST** include return freight funds and are fully responsible for all documents, duties, tariffs, and deposits.

## 7 Technical Data

### Technical Information and specifications – also see *PVI 3000-5300 brochure for information and on the inverters. (see Appendix B for info).*

Input (DC) from PV array:

- Maximum open circuit voltage of PV array: 600V DC

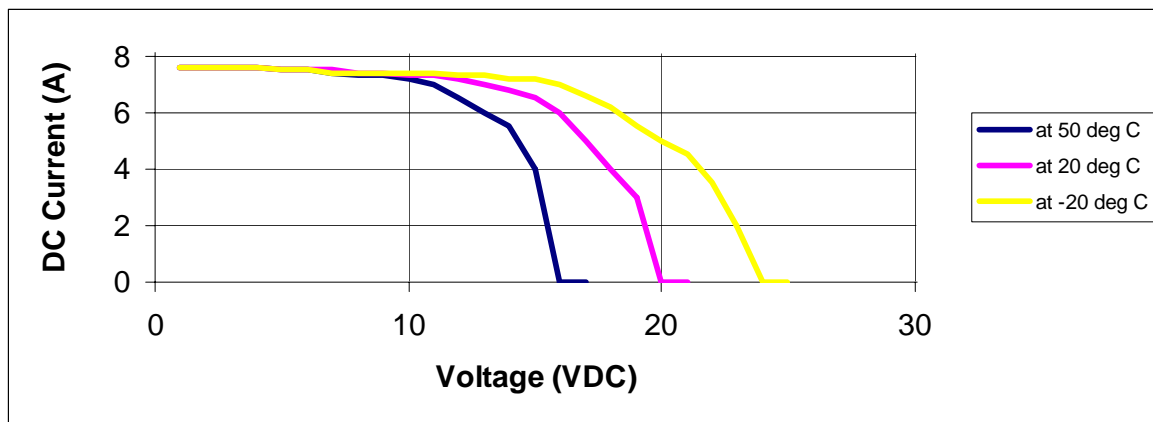


**WARNING:** NEC 690-7 must be followed to calculate the maximum number of PV modules allowed for a maximum inverter open circuit voltage (OCV) of 600V DC in extreme cold temperatures for the installation location.

- See PV string sizing chart example in Appendix C.



The open circuit voltage of PV modules depends on the cell temperature and the solar irradiation. The highest open circuit voltage occurs when the PV modules are at the coldest temperature and in bright sun. (See the following figure – Fig. 10)



**Fig. 7.1 Example representative ~100W PV module voltage – current characteristic at various cell temperatures**

Because PV modules also have a reduction in voltage at high cell temperatures, you must make sure the MPP voltage of the strings will not drop below the minimum inverter DC input voltage of 200V DC in very hot temperature conditions, including wire losses/voltage drop.

Both the maximum open circuit voltage (OCV) when at cold extreme and minimum MPP voltage when at hot extreme can be calculated for a PV module using its specification sheet. PV module string sizing can then be used to determine how many modules can/should be used in a string.

## Inverter Specifications

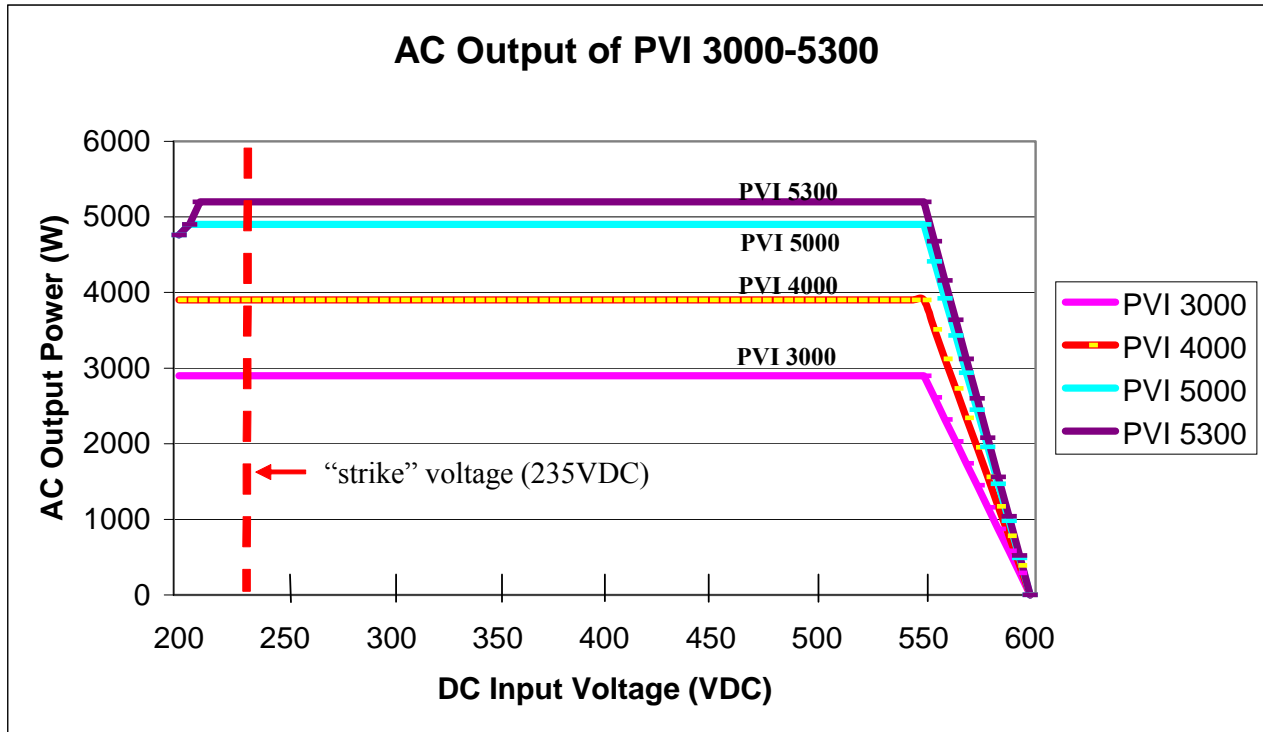
	PVI 3000	PVI 4000	PVI 5000	PVI 5300
<b>DC Input Specifications</b>				
Continuous Power @240 VAC @208 VAC	3050W 2840W	4100W 3580W	5150W 4520W	5575W 4840W
Recommended Max. PV @240 VAC Array Power, STC Rating @208 VAC	3600W 3400W	4900W 4300W	6200W 5400W	6700W 5800W
MPPT Voltage Range	200V-550 VDC	200V-550 VDC	200V-550 VDC	200V-550 VDC
Maximum Input Voltage	600 VDC	600 VDC	600 VDC	600 VDC
Strike Voltage	235 VDC	235 VDC	235 VDC	235 VDC
Maximum Input Current	16 A	20 A	25 A	25 A
Maximum Short Circuit Current	24 A	24 A	30 A	30 A
Fused Inputs	3	4	4	4
<b>AC Output Specifications</b>				
Continuous Power @240 VAC @208 VAC	2900W 2700W	3900W 3400W	4900W 4300W	5300W 4600W
Voltage Range @240 VAC @208 VAC	211-264 VAC 183-228 VAC	211-264 VAC 183-228 VAC	211-264 VAC 183-228 VAC	211-264 VAC 183-228 VAC
Frequency	60Hz Range: 59.3-60.5Hz	60Hz Range: 59.3-60.5Hz	60Hz Range: 59.3-60.5Hz	60Hz Range: 59.3-60.5Hz
Continuous Current	13 A	16.3 A	20.7 A	22.1 A
Output Current Protection	20 A	25 A	30 A	30 A
Max. Backfeed Current to PV	0 A	0 A	0 A	0 A
Power Factor	Utility, >99%	Utility, >99%	Utility, >99%	Utility, >99%
THD	<3%	<3%	<3%	<3%
Efficiency Peak @240 VAC @208 VAC	96.7 96.4	96.7 96.5	96.6 96.4	96.4 96.2
CEC Efficiency @240 VAC @208 VAC	96 95.5	96 95.5	96 96.0	96 95.5
<b>General</b>				
Enclosure	Rainproof, NEMA 3R			
Housing Material	Painted aluminum			
Ambient Temperature Range	-25°C to +55°C			
Cooling	Convection	Convection and fan assist		
Weight	50.7 lb (23 kg)	50.7 lb (23 kg)	61.7 lb (28 kg)	61.7 lb (28 kg)
Size (L x W x H)	28 4/5 in x 17 3/4 in x 6 3/4 in (732mm x 454mm x 175mm) 28 4/5 in x 17 3/4 in x 8 1/4 in (732mm x 454mm x 210mm)			
Wire Sizes	12 to 6 AWG input and output connections			
Standards	UL1741/IEEE1547, IEEE1547.1, ANSI62.41.2, FCC part 15 B			
Warranty	10 years standard			



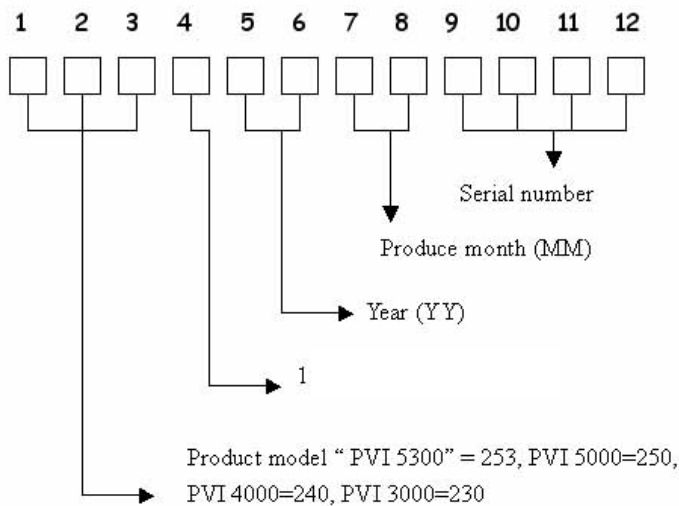
This maximum recommended power is a nominal figure based on an array with a relatively optimal tilt angle and orientation (south) as well as other average conditions. Array over-sizing is used because PV modules rarely run at their STC ratings. However, if the array is oversized too much clipping of maximum power by the inverter can occur in optimal conditions. PV module STC conditions are rarely achieved because the cells are usually at a higher temperature when full 1-sun is available, or when cells are at STC temperatures, the sun's intensity is often times less than 1-sun. Because STC conditions are rarely achieved, array over-sizing of 10-20% achieves best overall economic trade-off with inverter and array costs. The maximum recommended power to be connected to the inverter is very much dependent on average weather conditions, economic optimization, tilt and of the array and orientation (for example south, or rotating array). For arrays that are flat or nearly flat in northern location where the sun's rays are never close to being perpendicular to the array, the array can be oversized more than these recommendations. For locations that are hazy or cloudy for most of the year, also more array over-sizing may be appropriate. For arrays aiming at the sun or rotating arrays that face the sun all the time, less array over-sizing may be a good choice.

**Output to AC grid connection:**

The PVI 3000-5300 is designed to feed power into a standard 60Hz, 240 or 208V AC utility service or 208V AC provided within a facility by a step down transformer (for example, from 480V AC service). As required by NEC, there must be a dedicated 2-pole circuit breaker for the PV inverter connection. This circuit breaker (and wiring) must have a rating of 20, 25 or 30A depending on the model. The inverter is designed to work with the range of AC voltage for a 240VAC or 208V service defined by UL1741/IEEE1547.



**Fig. 7.2 AC Output power of PVI 3000-5300**



**Fig. 7.3 Serial Number Key (description)**

# Appendices

## Appendix A: PVI 3000/4000/5000/5300 brochure

The brochure can also be viewed on the website: [http://www.solren.com/downloads/PVI\\_3000-5300 kW.pdf](http://www.solren.com/downloads/PVI_3000-5300 kW.pdf)

## Appendix B: Example string sizing PVI 3000/4000/5000/5300

(Note that the chart below is only to show how string sizing charts look. Please refer to the website version for complete and updated charts for use in all temperature zones across the country.)

Updated string sizing tables are available on the website: [www.solren.com](http://www.solren.com)

All string sizing charts in: <http://www.solren.com/products/pwreleccomp.html>

Specific PVI 3000-53000 Link:

[http://www.solren.com/downloads/Solectria\\_Renewables\\_String\\_Sizing\\_PVI\\_3000-5300\\_String\\_Sizing\\_as\\_of\\_5\\_21\\_08.pdf](http://www.solren.com/downloads/Solectria_Renewables_String_Sizing_PVI_3000-5300_String_Sizing_as_of_5_21_08.pdf)

Module Manufacturer	BP Solar																			
Module Model	SX 3195		Power @ MPT (STC)	195.0 W																
Voltage @ MPT (STC)	24.4 VDC	PTC Power Rating	173.0 W																	
Current @ MPT (STC)	7.96 ADC	Temp Coeff of V <sub>mpt</sub>	0.125 V/degC	(V <sub>mpt</sub> )																
Current, short circuit	8.6 ADC	Temp Coeff of V <sub>ocv</sub>	0.111 V/degC	(V <sub>ocv</sub> )																
OCV @ 25 deg C cells	30.7 VDC	NOCT (nom. cell temp)	47 deg C	116.6 deg F																
Modules total in array	11	12	13	14	15	16	17	22	24	26	28	30	32	34	33	36				
Modules per string	11	12	13	14	15	16	17	11	12	13	14	15	16	17	11	12				
Strings in Parallel	1	1	1	1	1	1	1	2	2	2	2	2	2	2	3	3				
Voltage @ MPT (STC)	268.4	292.8	317.2	341.6	366.0	390.4	414.8	268.4	292.8	317.2	341.6	366.0	390.4	414.8	268.4	292.8				
V <sub>mpt</sub> @ max amb temp (30C, 86F amb)	217.5	237.3	257.1	276.9	296.6	316.4	336.2	217.5	237.3	257.1	276.9	296.6	316.4	336.2	217.5	237.3				
V <sub>mpt</sub> @ max amb temp (35C, 95F amb)	210.7	229.8	249.0	268.1	287.3	306.4	325.6	210.7	229.8	249.0	268.1	287.3	306.4	325.6	210.7	229.8				
V <sub>mpt</sub> @ max amb temp (40C, 104F amb)	203.8	222.3	240.8	259.4	277.9	296.4	314.9	203.8	222.3	240.8	259.4	277.9	296.4	314.9	203.8	222.3				
V <sub>mpt</sub> @ max amb temp (45C, 113F amb)	196.9	214.8	232.7	250.6	268.5	286.4	304.3	196.9	214.8	232.7	250.6	268.5	286.4	304.3	196.9	214.8				
V <sub>mpt</sub> @ max amb temp (50C, 122F amb)	190.0	207.3	224.6	241.9	259.1	276.4	293.7	190.0	207.3	224.6	241.9	259.1	276.4	293.7	190.0	207.3				
OCV @ 25 deg C cells	337.7	368.4	399.1	429.8	460.5	491.2	521.9	337.7	368.4	399.1	429.8	460.5	491.2	521.9	337.7	368.4				
OCV @ coldest temp (-40C, -40F amb)	417.1	455.0	492.9	530.8	568.7	606.6	644.6	417.1	455.0	492.9	530.8	568.7	606.6	644.6	417.1	455.0				
OCV @ coldest temp (-30C, -22F amb)	404.9	441.7	478.5	515.3	552.1	588.9	625.7	404.9	441.7	478.5	515.3	552.1	588.9	625.7	404.9	441.7				
OCV @ coldest temp (-20C, -4F amb)	392.6	428.3	464.0	499.7	535.4	571.1	606.8	392.6	428.3	464.0	499.7	535.4	571.1	606.8	392.6	428.3				
OCV @ coldest temp (-10C, 14F amb)	380.4	415.0	449.6	484.2	518.8	553.4	587.9	380.4	415.0	449.6	484.2	518.8	553.4	587.9	380.4	415.0				
OCV @ coldest temp (0C, 32F amb)	368.2	401.7	435.2	468.7	502.1	535.6	569.1	368.2	401.7	435.2	468.7	502.1	535.6	569.1	368.2	401.7				
Power @ MPT (STC)	2145	2340	2535	2730	2925	3120	3315	4290	4680	5070	5460	5850	6240	6630	6435	7020				
PTC AC system power rating	1827	1993	2159	2325	2491	2657	2823	3654	3986	4318	4650	4982	5315	5647	5481	5979				
Inverter Recommended	PVI 3000	PVI 3000	PVI 3000	PVI 3000	PVI 3000	PVI 3000	PVI 3000	PVI 4000	PVI 5000	PVI 5000	PVI 5000	PVI 5000	PVI 5300	PVI 5300	PVI 5300	PVI 5300				

## Appendix C: Contact Information

Authorized Dealers and Installers – see website: [www.solren.com](http://www.solren.com)

Specific link: <http://www.solren.com/contact/dist.htm>

Solectria Renewables LLC  
 360 Merrimack Street  
 Building 9  
 Lawrence, Massachusetts, 01843  
 USA


Tel: 978.683-9700  
 Fax: 978.683-9702  
 Email: [inverters@solren.com](mailto:inverters@solren.com)  
 Website: [www.solren.com](http://www.solren.com)

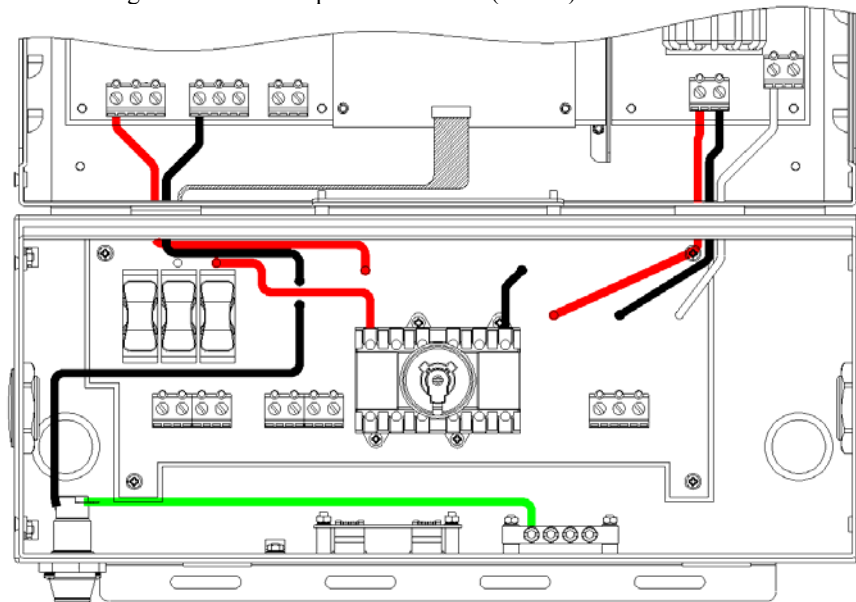


## Appendix D – Negative Grounding and Positive Grounding Option

### Connection of the DC wiring

The wiring box of the PVI 3000-5300 inverter is designed with a pair of DC terminal blocks which support up to four (4) independent PV strings to be connected in parallel in the wiring box and then feed into the inverter. The inverters other than PVI 3000 are shipped with up to four (4) 15A, 600Vdc PV string fuses for the PV strings. The PVI 3000 is shipped with three (3) 15A, 600Vdc PV string fuses, and therefore, the fourth pair of terminals (from left as shown in figure D1) are not be used to connect to a PV string. However, the size of the PV string fuse shall be determined by the electrical ratings of the PV module and by UL and National Electrical Code (NEC) requirements. Please refer to the section 5.4.2 for the replacement of the PV string fuses.

There are two (2) terminals, labeled “+” and “-”, per PV string located in the wiring box used for the DC connections. The DC equipment ground wire shall be connected to the screw of the ground bar labeled  in the wiring box of the inverter. All the screws shall be tightened with a torque of 15.6 Lb-in (1.7Nm).



*Fig D1 PVI 3000 supports only three (3) PV string fuses*

The inverters supports both negative and positive ground for PV strings connections. The JP14 and JP15 jumpers are used for the settings of the negative and positive grounding.

### Connection of the DC wiring for Negative Grounded Systems

When the inverter is shipped with the negative ground setting, it is set as shown in the figure D2. The JP14 and JP15 jumpers are placed on the lower positions to set to the negative ground and the red Vdc wire is connected to DCIN+ terminal, the black Vdc wire is connected to DCIN- terminal. In this case the positive polarity of the DC input from the PV string shall be connected to PV+ terminal and the negative polarity of the DC input from the PV string shall be connected to PV- terminal as shown in the figure D3.

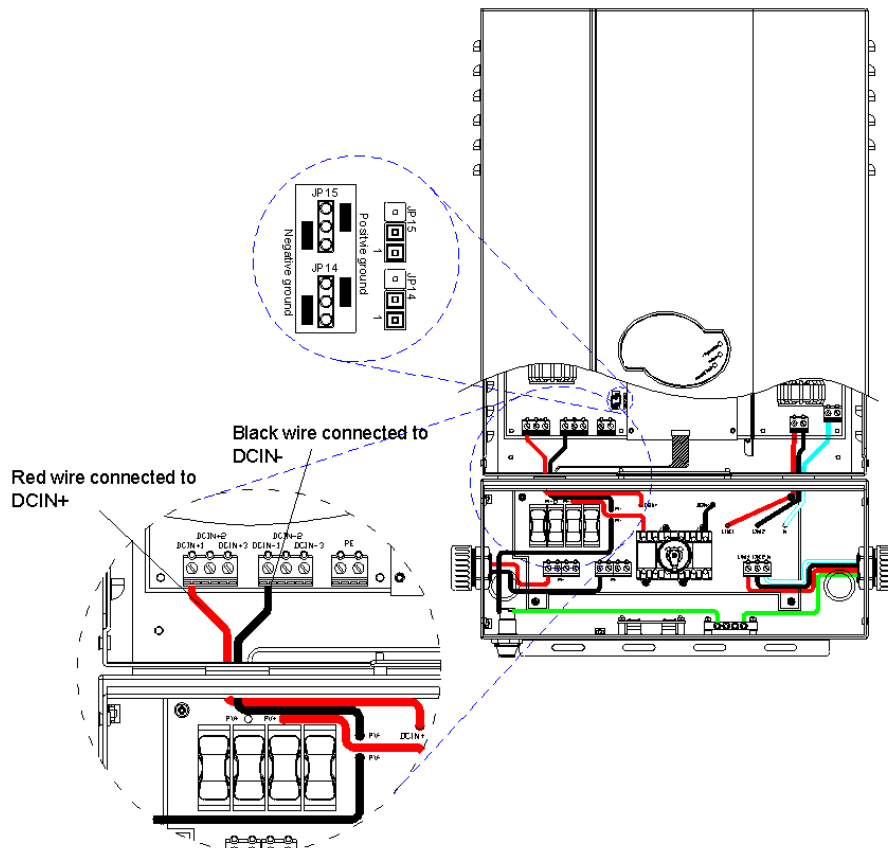


Fig D2 Negative Ground Setting and Vdc wires connections

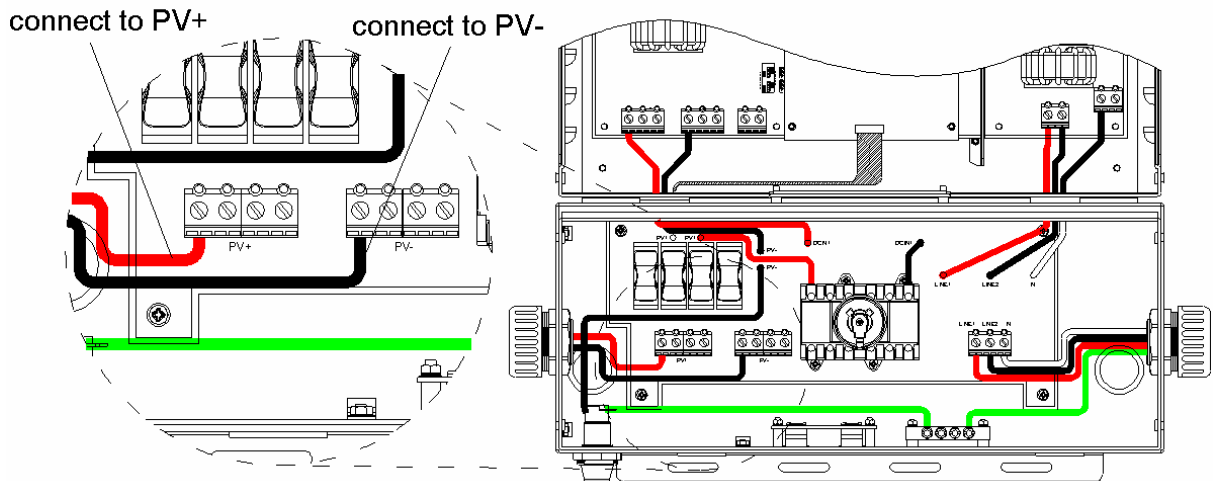



Fig D3 DC terminal blocks for DC cable connection in Negative Ground

**CAUTION!**



Polarities of each DC input from a PV string shall be correctly connected to the “+” (positive) and “-” (negative) terminals of a pair respectively. The DC voltage must be less than 600V in any condition.

The “+” wire of the DC input shall be connected to the terminal labeled “PV+” and the “-” wire of the DC input shall be connected to the terminal labeled “PV-”.

- Avoid using wire nuts to join any wires together or to make any connections in the PV system. Wire nuts are a frequent cause of unreliable connections, resistive connections, and ground faults.
- Connect the equipment ground cable to the screw of the ground bar labeled .

Tighten the screws with a torque of 15.6 Lb-in (1.7Nm).

### Connection of the DC wiring for Positive Grounded Systems

The PVI 3000-5300 inverter also supports positive ground for some applications. This option should be ordered from the factory if positive grounding is desired. If ordered as positively grounded with the “P” suffix on the part number, it will come with a label on the front stating that it is a Positive Grounded unit and the PV+ and PV- will be labeled for positively grounded, etc. The connections to the array follow the same instructions as above for hook up. If any inverter is ordered as negatively grounded, it can be “converter” to positively grounded following these instructions:

- 1.) Open the wiring box (lower unit with DC disconnect in the center) and remove the inverter cover (upper unit)
- 2.) As shown in the figure D4, below, the JP14 and JP15 jumpers need to be placed at the higher positions to set to positive grounding.
- 3.) The **red** DC wire (that connects the inverter board to the wiring box below) needs to be connected to DCIN- (labeled “PV-“) terminal on the wiring box PCB and the **black** DC wire (that connects the inverter board to the wiring box below) needs to be connected to DCIN+ terminal on the wiring box PCB.
- 4.) Add permanent weatherproof labels over the PV+ and PV- labels below the green terminal blocks. The left terminal block must be labeled “PV-“ and the right terminal block must be labeled “PV+“. Optional: add “Warning, Positively Grounded Unit” label to outside of unit at bottom right corner of wiring box. (a label kit is available from Solectria if requested).

In this case the installer shall connect the positive polarity of the DC input from the PV string(s) to the original PV- terminal(s) which are now labeled “PV+“ and the negative polarity of the DC input from the PV string(s) shall be connected to original PV+ terminal(s) now labeled “PV-“ as shown in the figure D5.

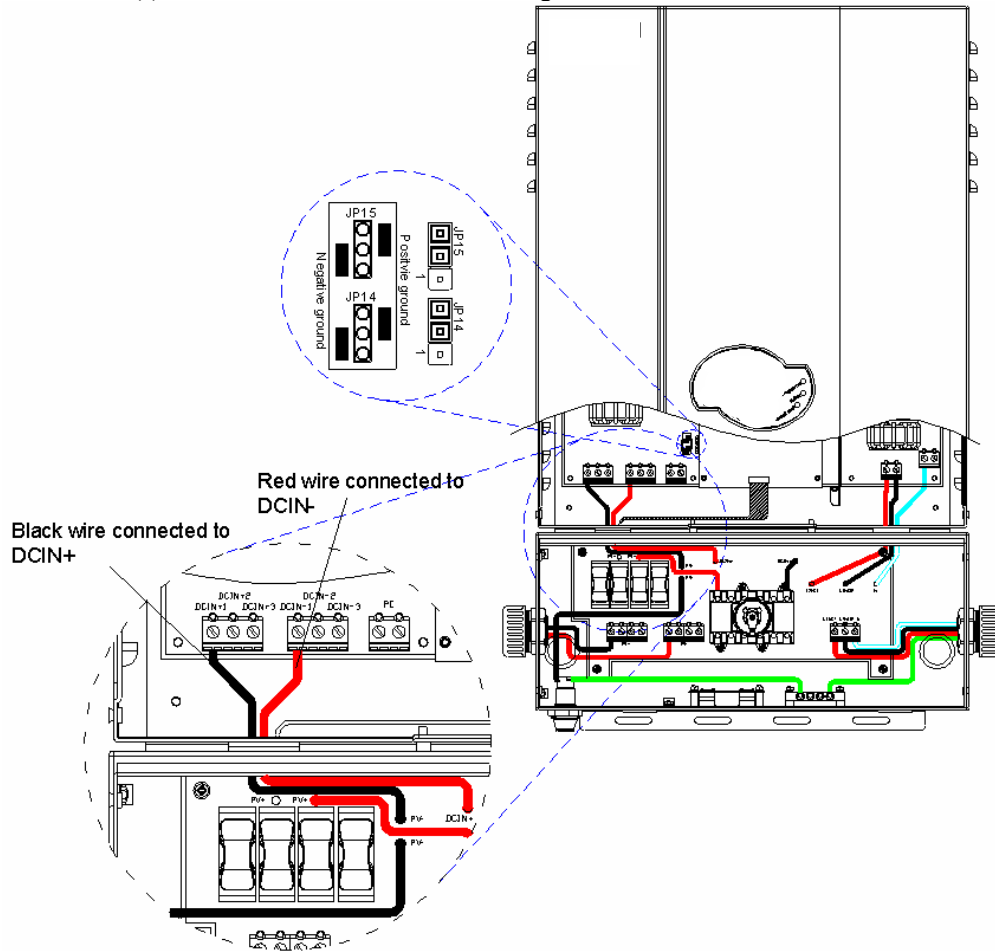


Fig D4 Positive Ground Setting and Vdc wires connections

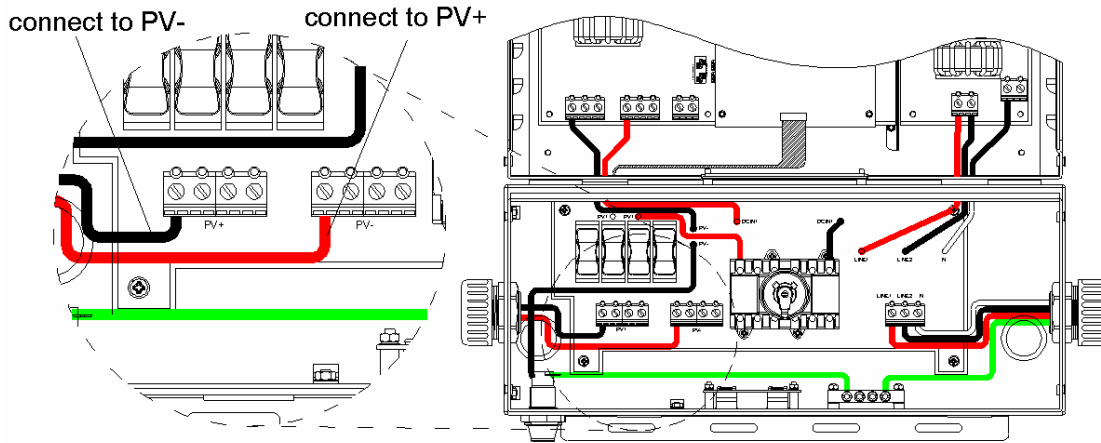



Fig D5 DC terminal blocks for DC cable connection in Positive Ground



**CAUTION!**

The Positive Polarities of the DC input from a PV strings shall be correctly connected to the original “-” (negative) terminals (re-labeled “+”) and the Negative Polarity of the DC input from a PV string shall be connected to the original “+” (positive) terminals (re-labeled “-“). The DC voltage must be less than 600V in all conditions.

- Avoid using wire nuts to join any wires together or to make any connections in the PV system. Wire nuts are a frequent cause of unreliable connections, resistive connections, and ground faults.
- Connect the equipment ground wire to the screw of the ground bar labeled 
- Tighten the screws with a torque of 15.6 lb-in (1.7Nm).



**CAUTION!**

PV arrays are energized when ex-posed to light. Use safe working practices when working on PV arrays.



**WARNING!**

Route the DC connection cables to the inverters away from any possible hazards that could damage the cables.



**WARNING!**

Hazardous voltage is still present on the device after is it disconnected from all PV DC inputs. Allow 5 minutes for the inverter to discharge the energy completely.

- Up to four (4) independent PV strings (4 pairs) can be connected to the inverter as shown in the figure 3C. The PV strings are connected in parallel in the wiring box. Therefore, these four (4) PV strings shall be the same in capacity, especially each total string voltage.

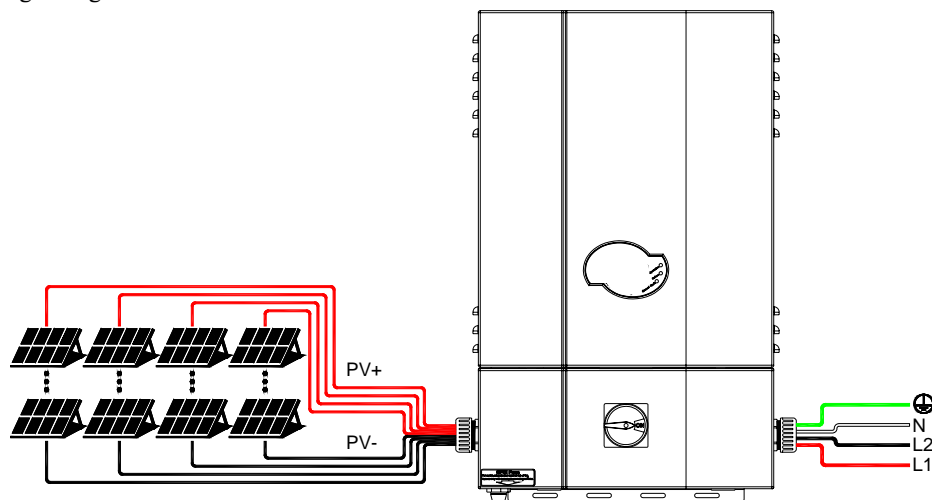


Fig D6 PV- terminal connection

**Appendix D. PVI 3000-5300 PV Inverter Fault Report Form**

<b>Basic information</b>																							
Model (i.e. “PVI 3000”)																							
Serial number																							
Purchased from																							
Purchased date	_____Y/_____M/_____D																						
<b>Installation information</b>																							
Type of installation	<input type="checkbox"/> Residential <input type="checkbox"/> Commercial																						
Installation date	_____Y/_____M/_____D																						
First operation date	_____Y/_____M/_____D																						
AC wire size and length	_____ AWG wire size    feet length of wire																						
DC wire size and length	_____ AWG wire size    feet length of wire																						
PV panel mount	<input type="checkbox"/> Roof <input type="checkbox"/> Pole <input type="checkbox"/> Ground																						
Solar tracker	<input type="checkbox"/> Yes <input type="checkbox"/> No																						
<b>PV strings</b>																							
Output power																							
Normal voltage range	Vdc																						
Peak open circuit voltage	Vdc																						
Normal current rating	Adc																						
maximum current rating	Adc																						
Number of panels																							
Number of series/parallel	_____S/_____P																						
PV panel brand & model																							
<b>Fault/error information (please write down exact words that appear on the LCD)</b>																							
Fault message 1 on LCD	<table border="1" style="width:100%; height: 1.5em;"><tr><td> </td><td> </td><td> </td><td> </td><td> </td><td> </td><td> </td><td> </td><td> </td><td> </td><td> </td><td> </td><td> </td><td> </td><td> </td><td> </td><td> </td><td> </td><td> </td><td> </td><td> </td><td> </td></tr></table>																						
Fault message 2 on LCD	<table border="1" style="width:100%; height: 1.5em;"><tr><td> </td><td> </td><td> </td><td> </td><td> </td><td> </td><td> </td><td> </td><td> </td><td> </td><td> </td><td> </td><td> </td><td> </td><td> </td><td> </td><td> </td><td> </td><td> </td><td> </td><td> </td><td> </td></tr></table>																						
Fault message 3 on LCD	<table border="1" style="width:100%; height: 1.5em;"><tr><td> </td><td> </td><td> </td><td> </td><td> </td><td> </td><td> </td><td> </td><td> </td><td> </td><td> </td><td> </td><td> </td><td> </td><td> </td><td> </td><td> </td><td> </td><td> </td><td> </td><td> </td><td> </td></tr></table>																						
Fault message 4 on LCD	<table border="1" style="width:100%; height: 1.5em;"><tr><td> </td><td> </td><td> </td><td> </td><td> </td><td> </td><td> </td><td> </td><td> </td><td> </td><td> </td><td> </td><td> </td><td> </td><td> </td><td> </td><td> </td><td> </td><td> </td><td> </td><td> </td><td> </td></tr></table>																						
Fault message 5 on LCD	<table border="1" style="width:100%; height: 1.5em;"><tr><td> </td><td> </td><td> </td><td> </td><td> </td><td> </td><td> </td><td> </td><td> </td><td> </td><td> </td><td> </td><td> </td><td> </td><td> </td><td> </td><td> </td><td> </td><td> </td><td> </td><td> </td><td> </td></tr></table>																						
Fault message 6 on LCD	<table border="1" style="width:100%; height: 1.5em;"><tr><td> </td><td> </td><td> </td><td> </td><td> </td><td> </td><td> </td><td> </td><td> </td><td> </td><td> </td><td> </td><td> </td><td> </td><td> </td><td> </td><td> </td><td> </td><td> </td><td> </td><td> </td><td> </td></tr></table>																						
Description of problem	-Does this failure happen regularly or intermittently? -Can you reproduce the failure? -How much energy has been produced thus far? (kWh)																						

Form filled out by \_\_\_\_\_

Date \_\_\_\_\_

Appendix D – UL1741/IEEE1547 Listing Letter



165 Main Street  
Cortland, NY 13045

Telephone: +1 607 758 6438  
Facsimile: +1 607 758 9608  
[www.intertek-etlsemko.com](http://www.intertek-etlsemko.com)

### Listing Certificate

To: Whom it may concern  
Email:  
Fax:  
Ph:  
cc:

Re: Listing Verification

Date: July 21, 2008

Pages: 1, including cover sheet

The following Company/product(s) is listed for use with the ETL Listed Mark(s).

Standard(s): Safety Inverters, Converters, & Controllers for Use in Independent Power Systems (UL-1741).  
Company: SOLECTRIA RENEWABLES, LLC. - Lawrence, MA USA  
Product(s): PV Inverter.  
Model(s): PVI followed by 3000, 3000-P, 4000, 4000-P, 5000, 5000-P, 5300, 5300-P.

If you have any further questions, please feel free to call me at 1-800-345-3851 ext. 438.

Regards,

Debbie Nadge, Accreditation Secretary



Confidentiality Notice: The information contained in this facsimile transmittal is privileged and confidential. It is intended only for the use of the addressee. If the reader of this message is not the intended recipient, or person responsible to deliver it to the intended recipient, you are hereby notified that any dissemination, distribution or copy of this facsimile transmittal is strictly prohibited. If you have received this transmittal in error, please notify us immediately by telephone and please return the original transmittal to the address above. Thank you.