

Conext™ XW+ Inverter/Charger

Conext XW+ 6848 NA

Conext XW+ 5548 NA

Installation Guide

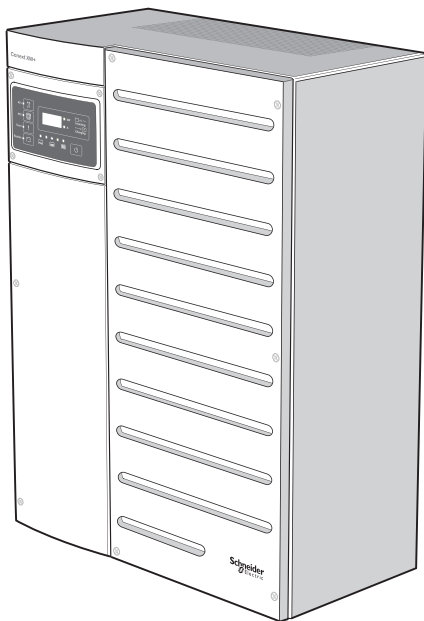

Conext™ XW+

Inverter/Charger

Installation Guide

Copyright © 2007-2014 Schneider Electric. All Rights Reserved.

All trademarks are owned by Schneider Electric Industries SAS or its affiliated companies.

Exclusion for Documentation

UNLESS SPECIFICALLY AGREED TO IN WRITING, SELLER

(A) MAKES NO WARRANTY AS TO THE ACCURACY, SUFFICIENCY OR SUITABILITY OF ANY TECHNICAL OR OTHER INFORMATION PROVIDED IN ITS MANUALS OR OTHER DOCUMENTATION;

(B) ASSUMES NO RESPONSIBILITY OR LIABILITY FOR LOSSES, DAMAGES, COSTS OR EXPENSES, WHETHER SPECIAL, DIRECT, INDIRECT, CONSEQUENTIAL OR INCIDENTAL, WHICH MIGHT ARISE OUT OF THE USE OF SUCH INFORMATION. THE USE OF ANY SUCH INFORMATION WILL BE ENTIRELY AT THE USER'S RISK; AND

(C) REMINDS YOU THAT IF THIS MANUAL IS IN ANY LANGUAGE OTHER THAN ENGLISH, ALTHOUGH STEPS HAVE BEEN TAKEN TO MAINTAIN THE ACCURACY OF THE TRANSLATION, THE ACCURACY CANNOT BE GUARANTEED. APPROVED CONTENT IS CONTAINED WITH THE ENGLISH LANGUAGE VERSION WHICH IS POSTED AT WWW.SESOLAR.COM.

Date and Revision

March 2014 Rev H

Document Part Number

975-0239-01-01

Product Part Numbers

Product Part Numbers

865-6848-01 – Conext XW+ 6848 NA

865-5548-01 – Conext XW+ 5548 NA

Related Product Part Numbers

865-1015-01 – Conext XW+ Power Distribution Panel

865-1025 – Conext XW+ Conduit Box

865-1020-01 – Conext XW+ Connection Kit for INV2 INV3 PDP

865-1030-1 – Conext MPPT 60 150 Solar Charge Controller

865-1032 – Conext MPPT 80 600 Solar Charge Controller

865-1050-01 – Conext System Control Panel

865-1060-01 – Conext Automatic Generator Start

865-1058 – Conext ComBox

865-1080-01 – Conext Battery Monitor

Contact Information

www.SEsolar.com

Please contact your local Schneider Electric Sales Representative or visit our website at:

<http://www.schneider-electric.com/sites/corporate/en/support/operations/local-operations/local-operations.page>

Information About Your System

As soon as you open your product, record the following information and be sure to keep your proof of purchase.

Serial Number _____

Product Number _____

Purchased From _____

Purchase Date _____

About This Guide

Purpose

The purpose of this Installation Guide is to provide explanations and procedures for installing the Schneider Electric Conext XW+ Inverter/Charger.

Scope

The Guide provides safety guidelines, detailed planning, and procedures for installing the Conext XW+ Inverter/Charger and related system components. It does not provide details about configuration, operation, maintenance, or troubleshooting. See the Operation Guide or Owner's Guide of each device for this information. This Guide does not provide details about particular brands of batteries, photoelectric cells, or generators. Consult individual battery manufacturers for this information.

Audience

This Installation Guide is intended for any qualified personnel planning to install the Conext XW+ Inverter/Charger and related system components. Qualified personnel have training, knowledge, and experience in:

- Installing electrical equipment
- Applying applicable installation codes
- Analyzing and reducing the hazards involved in performing electrical work
- Installing and configuring batteries
- Selecting and using Personal Protective Equipment (PPE)

Servicing of batteries must only be performed or supervised by qualified personnel knowledgeable of batteries and the required precautions. Keep unqualified personnel away from batteries.

No responsibility is assumed by Schneider Electric for any consequences arising out of the use of this material.

Organization

This Guide is organized into five chapters and three appendices.

Chapter 1, "Introduction" lists and describes the components and basic features of the Conext XW+ Inverter/Charger.

Chapter 2, “Pre-Installation and Wall-Mounting” describes the pre-installation steps, and gives instructions for wall-mounting the Conext XW+, Conext XW+ Power Distribution Panel and Conext XW+ Conduit Box.

Chapter 3, “Wiring the Conext XW+ Inverter/Charger and Conext XW+ Power Distribution Panel” describes procedures for installing the Conext XW+ Inverter/Charger.

Chapter 4, “Xanbus Network Installation” provides detailed information for planning and installing the components necessary for network communication on a Xanbus system.

Chapter 5, “Conext XW+ Inverter/Charger Accessories Installation” provides detailed instructions for installing certain accessories for your Conext XW+ Inverter/Charger.

Appendix A, “Specifications” provides the electrical and mechanical specifications for the Conext XW+ Inverter/Charger.

Appendix B, “Wiring Diagrams” illustrate the most basic configurations and are for reference only. Specific installations may require additional equipment to meet national or local electric codes. Ensure all safety requirements are strictly followed.

Appendix C, “Split-Phase to Single-Phase Conversion Instructions” provides instructions for converting a Conext XW+ Inverter/Charger 120 V/240 V, split-phase model to a 120 V, single-phase model.

Conventions Used

The following conventions are used in this Guide.

Abbreviations and Acronyms

CEC	California Energy Commission
CSA	Canadian Standards Association
GT	Grid Tie
LCD	Liquid Crystal Display
LED	Light Emitting Diode
MPPT	Maximum Power Point Tracking
NEC	US National Electrical Code NFPA-70
PV	Photovoltaic
PVGFP	PV Ground Fault Protection
UL	Underwriters Laboratories
VAC	Volts AC
VDC	Volts DC

Related Information

For information about operating the Conext XW+ Inverter/Charger, see the *Conext XW+ Inverter/Charger Owner's Guide* (975-0240-01-01).

You can find more information about Schneider Electric as well as its products and services at www.SEsolar.com.

For available accessories, see “Optional Accessories” on page 1–5.

Important Safety Instructions

READ AND SAVE THESE INSTRUCTIONS - DO NOT DISCARD

This guide contains important safety instructions for the Conext XW+ Inverter/Charger that must be followed during installation procedures. **Read and keep this Installation Guide for future reference.**

Read these instructions carefully and look at the equipment to become familiar with the device before trying to install, operate, service or maintain it. The following special messages may appear throughout this bulletin or on the equipment to warn of potential hazards or to call attention to information that clarifies or simplifies a procedure.



The addition of either symbol to a “Danger” or “Warning” safety label indicates that an electrical hazard exists which will result in personal injury if the instructions are not followed.



This is the safety alert symbol. It is used to alert you to potential personal injury hazards. Obey all safety messages that follow this symbol to avoid possible injury or death.

DANGER

DANGER indicates a hazardous situation which, if not avoided, will result in death or serious injury.

WARNING

WARNING indicates a hazardous situation which, if not avoided, could result in death or serious injury.

CAUTION

CAUTION indicates a hazardous situation which, if not avoided, could result in minor or moderate injury.

NOTICE

NOTICE is used to address practices not related to physical injury. The safety alert symbol shall not be used with this signal word.
--

Safety Information

- 1. Before using the inverter, read all instructions and cautionary markings on the unit, the batteries, and all appropriate sections of this manual.**
2. Use of accessories not recommended or sold by the manufacturer may result in a risk of fire, electric shock, or injury to persons.
3. The inverter is designed to be permanently connected to your AC and DC electrical systems. The manufacturer recommends that all wiring be done by a certified technician or electrician to ensure adherence to the local and national electrical codes applicable in your jurisdiction.
4. To avoid a risk of fire and electric shock, make sure that existing wiring is in good condition and that wire is not undersized. Do not operate the inverter with damaged or substandard wiring.
5. Do not operate the inverter if it has been damaged in any way.
6. This unit does not have any user-serviceable parts. Do not disassemble the inverter except where noted for connecting wiring and cabling. See your warranty for instructions on obtaining service. Attempting to service the unit yourself may result in a risk of electrical shock or fire. Internal capacitors remain charged after all power is disconnected.
7. To reduce the risk of electrical shock, disconnect both AC and DC power from the inverter before attempting any maintenance or cleaning or working on any components connected to the inverter. Putting the unit in Standby mode will not reduce this risk.
8. The inverter must be provided with an equipment-grounding conductor connected to the AC input ground.
9. Do not expose this unit to rain, snow, or liquids of any type. This product is designed for indoor use only. Damp environments will significantly shorten the life of this product and corrosion caused by dampness will not be covered by the product warranty.
10. To reduce the chance of short-circuits, always use insulated tools when installing or working with this equipment.
11. Remove personal metal items such as rings, bracelets, necklaces, and watches when working with electrical equipment.

⚠ DANGER**HAZARD OF ELECTRIC SHOCK, EXPLOSION, OR ARC FLASH**

- Apply appropriate personal protective equipment (PPE) and follow safe electrical work practices. See NFPA 70E or CSA Z462.
- This equipment must only be installed and serviced by qualified electrical personnel.
- Never operate energized with covers removed
- Energized from multiple sources. Before removing covers identify all sources, de-energize, lock-out, and tag-out and wait 2 minutes for circuits to discharge
- Always use a properly rated voltage sensing device to confirm all circuits are de-energized.

Failure to follow these instructions will result in death or serious injury.

⚠ DANGER**HAZARD OF ELECTRIC SHOCK, EXPLOSION, OR ARC FLASH**

- Remove watches, rings, or other metal objects.
- This equipment must only be installed and serviced by qualified electrical personnel.
- Keep sparks and flames away from the batteries.
- Use tools with insulated handles.
- Wear protective glasses, gloves and boots.
- Do not lay tools or other metal parts on top of batteries.

Failure to follow these instructions will result in death or serious injury.

⚠ DANGER

HAZARD OF ELECTRIC SHOCK, EXPLOSION, OR ARC FLASH

- Battery Circuit Breakers must be installed according to the specifications and requirements defined by Schneider Electric.
- Servicing of batteries must only be performed by qualified personnel knowledgeable of batteries and the required precautions. Keep unqualified personnel away from batteries.
- Disconnect the charging source prior to connecting or disconnecting battery terminals.

Failure to follow these instructions will result in death or serious injury.

Limitations on Use

⚠ WARNING

LIMITATIONS ON USE

The Conext XW+ Inverter/Charger is not intended for use in connection with life support systems or other medical equipment or devices.

Failure to follow these instructions can result in death or serious injury.

Explosive Gas Precautions

⚠ DANGER

IGNITION HAZARD

This equipment is not ignition protected. To prevent fire or explosion, do not install this product in locations that require ignition-protected equipment. This includes any confined space containing vented batteries, or flammable chemicals such as, natural gas (NG), liquid petroleum gas (LPG) or gasoline (Benzine/Petrol).

- Do not install in a confined space with machinery powered by flammable chemicals, or storage tanks, fittings, or other connections between components of fuel or flammable chemical systems.

Failure to follow these instructions will result in death or serious injury.

Working in the vicinity of lead acid batteries is dangerous. Batteries generate explosive gases during normal operation. Therefore, you must read this Guide and follow the instructions exactly before installing or using your inverter/charger.

To reduce the risk of battery explosion, follow these instructions and those published by the battery manufacturer and the manufacturer of the equipment in which the battery is installed.

FCC Information to the User

This equipment has been tested and found to comply with the limits for a Class B digital device, pursuant to part 15 of the FCC Rules. These limits are designed to provide reasonable protection against harmful interference in a residential installation. This equipment generates, uses and can radiate radio frequency energy and, if not installed and used in accordance with the instructions, may cause harmful interference to radio communications. However, there is no

guarantee that interference will not occur in a particular installation. If this equipment does cause harmful interference to radio or television reception, which can be determined by turning the equipment off and on, the user is encouraged to try to correct the interference by one or more of the following measures:

- Reorient or relocate the receiving antenna.
- Increase the separation between the equipment and the receiver.
- Connect the equipment to a circuit different from that to which the receiver is connected.
- Consult the dealer or an experienced radio/TV technician for help.

Contents

Safety Information

Limitations on Use	-xi
Explosive Gas Precautions	-xi
FCC Information to the User	-xi

1 Introduction

Overview	1-2
Inside the Box	1-2
Conext XW+ Inverter/Charger and System Components	1-2
Battery Temperature Sensor	1-3
Conext XW Jumpers (For Single-Phase Conversion)	1-3
Conext XW+ Features	1-4
Optional Accessories	1-5
Conext XW+ Conduit Box	1-5
Conext XW+ Power Distribution Panel	1-5
Conext XW+ Connection Kit for INV2 INV3 PDP	1-7
Conext 120/240VAC Breaker Kit for Conext XW+ PDP	1-8
Conext MPPT 60 150 Solar Charge Controller	1-8
Conext MPPT 80 600 Solar Charge Controller	1-8
Conext System Control Panel	1-9
Conext Automatic Generator Start	1-9
Conext ComBox	1-10
Conext Battery Monitor	1-10
Conext 3 Phase Breaker Kit for Conext XW+ PDP	1-11
100A, 125VDC Breaker Master Pack (12 units)	1-11
80A, 125VDC Breaker Master Pack (12 units)	1-11
60A, 160VDC Breaker Master Pack (48 units)	1-11
250A, 160VDC Breaker Master Pack (6 units)	1-11

2 Pre-Installation and Wall-Mounting

Pre-Installation	2-2
Planning the Installation	2-2
Installation Tools and Materials	2-2
Location	2-3
Clearance Requirements	2-4
Knockout Selection	2-4
Air Filter and AUX Port Connector Installation	2-5

Wall-Mounting - - - - -	2-6
Installing the Mounting Plate - - - - -	2-8
Wall-Mounting the Conext XW+ and PDP - - - - -	2-9
Installing the Conext XW+ Conduit Box - - - - -	2-10
Communications Network Preparation - - - - -	2-12
Battery Bank Preparation - - - - -	2-13
Battery Bank Requirements - - - - -	2-14
Battery Cable Requirements - - - - -	2-14
Torque Values - - - - -	2-16
Torque values for the Conext XW+ - - - - -	2-16
Torque Values for the XW+ Power Distribution Panel - - - - -	2-16

3 Wiring the Conext XW+ and Power Distribution Panel

Removing the AC Access Panel and PDP Internal Faceplates - - - - -	3-2
AC Access Panel Removal - - - - -	3-2
Conext XW+ Power Distribution Panel Internal Faceplate Removal - - - - -	3-4
Communication Ports and BTS Port - - - - -	3-5
AUX Port - - - - -	3-5
AUX+12V Voltage Supply - - - - -	3-6
AUX-RPO: User Remote Power OFF (RPO) - - - - -	3-6
User Line Wiring - - - - -	3-7
AUX Port Terminal Assignments - - - - -	3-7
Wiring the Conext XW+ Inverter/Charger with a PDP - - - - -	3-7
Conext XW+ Inverter/Charger Grounding - - - - -	3-8
Grounding the DC System - - - - -	3-8
Battery Temperature Sensor Installation - - - - -	3-10
Making DC Connections - - - - -	3-11
Making AC Connections - - - - -	3-17
AC Terminal Block - - - - -	3-18
AC Equipment Grounding - - - - -	3-20
AC System Bonding - - - - -	3-21
AC wiring the Conext XW+ PDP to the Conext XW+ Inverter/Charger - - - - -	3-22
Wiring the Conext XW+ Power Distribution Panel to a Generator (On-Grid) - - - - -	3-24
Wiring the Conext XW+ Power Distribution Panel to a Generator (Off-Grid) - - - - -	3-25
AC Wiring to the Inverter Load Sub-Panel - - - - -	3-26
To connect the XW+ PDP to the Inverter Load Sub-Panel and Utility Grid - - - - -	3-28
Basic Functional Test – Single Inverter - - - - -	3-29
Confirming All Connections - - - - -	3-29
Applying DC Power to the Inverter - - - - -	3-30
Enabling the Inverter - - - - -	3-31
AC Voltage Check - - - - -	3-34
Confirming Battery Charger Operation - - - - -	3-34
Wiring Additional Conext XW+ units with a PDP - - - - -	3-37
Pre-Installation Steps - - - - -	3-38

Conext XW+ Inverter/Charger Grounding	3-40
Dual Inverter/Charger Installation	3-40
DC Grounding	3-40
DC positive bus bar installation	3-40
DC Wiring for a Dual-Inverter System	3-41
AC equipment grounding	3-43
Breaker installation	3-43
AC Wiring for a Dual-Inverter System	3-44
Bypass Interlock Plate Installation	3-46
Triple Inverter/Charger Installation	3-46
DC grounding	3-47
DC Positive Bus Bar installation	3-47
DC Wiring for a Triple-Inverter System	3-47
Power Distribution Jumper Preparation (for Triple-Inverter System Only)	3-48
Breaker Installation	3-49
AC equipment grounding	3-49
AC Wiring for a Triple-Inverter System	3-50
External Bypass Switch Installation	3-53
Basic Functional Test - Multiple Inverters	3-54
Wiring a Balanced Three-Phase System	3-56
Pre-Installation Steps	3-57
Conext XW+ Inverter/Charger Grounding	3-59
DC Wiring for a Three-Phase System	3-60
DC grounding	3-61
DC Positive Bus Bar installation	3-62
DC Wiring for a Balanced Three-Phase System	3-62
Breaker Installation	3-63
AC equipment grounding	3-64
AC Wiring for a Three-Phase System	3-65
Bypass Interlock Plate Installation (Three-Phase)	3-66
Wiring the Conext XW+ Inverter/Charger without a PDP	3-67
Pre-Installation Steps	3-68
Feed-in Protection Requirements	3-68
Conext XW+ Inverter/Charger Grounding	3-69
Grounding the DC System	3-69

4 Xanbus Network Installation

The Xanbus Network	4-2
Network Components	4-2
Xanbus-enabled devices	4-3
Xanbus power supply	4-3
Xanbus cables	4-4
Network terminators	4-4

Installing the Network - - - - -	4-4
Before You Begin the Installation - - - - -	4-5
Installation Tools and Materials - - - - -	4-5
Installing AC sync and Xanbus cables - - - - -	4-5
Guidelines for Routing the Xanbus Cables - - - - -	4-7
5 Conext XW Series Optional Accessories Installation	
Conext Combox Installation - - - - -	5-2
Conext System Control Panel Installation - - - - -	5-2
Installing the SCP via the Xanbus Network - - - - -	5-3
Replacing the Inverter Information Panel with the SCP - - - - -	5-4
Verifying the Installation - - - - -	5-7
A Specifications	
Electrical Specifications - - - - -	A-2
Grid-tie Specifications - - - - -	A-3
Conext XW+ Series Inverter/Charger Overload Capability - - - - -	A-4
Conext XW+ 6848 NA AC Overload Capability - - - - -	A-4
Conext XW+ 5548 NA AC Overload Capability - - - - -	A-4
Output Power Versus Ambient Temperature - - - - -	A-5
Conext XW+ Series Inverter/Charger Efficiency - - - - -	A-6
Inverting Efficiency (Typical) - - - - -	A-6
Charging Efficiency (Typical) - - - - -	A-6
Charging Power Factor - - - - -	A-7
Grid-tie Sell Mode Efficiency (Typical) - - - - -	A-7
Mechanical Specifications - - - - -	A-8
Accessories- - - - -	A-9
B Wiring Diagrams	
Single-Inverter System (Backup Only) Without a Conext XW+ Power Distribution Panel - - - - -	B-3
Single-Inverter System (Backup Only) With a Conext XW+ Power Distribution Panel - - - - -	B-4
Single-Inverter System Renewable Energy (Solar)- - - - -	B-5
Dual-Inverter System Renewable Energy (Solar)- - - - -	B-6
C Split-Phase to Single-Phase Conversion Instructions	
Converting 120 V/240 V Split-Phase to 120 V Single-Phase - - - - -	C-2
Installation Tools and Materials - - - - -	C-2
Disconnecting Power Sources - - - - -	C-3
AC Access Panel Removal - - - - -	C-3
Reconfiguring the Secondary Transformer Wires on X1 and X2 Connectors - - - - -	C-4
Reconfiguring the AC Ports on the Load, AC1, and AC2 Connectors - - - - -	C-6
Upgrading the Firmware - - - - -	C-7
Updating the Label - - - - -	C-8

1

Introduction

Chapter 1, “Introduction” lists and describes the components and basic features of the Conext XW+ Inverter/Charger.

Topics in this chapter include:

- “Overview” on page 1–2
- “Inside the Box” on page 1–2
- “Conext XW+ Features” on page 1–4
- “Optional Accessories” on page 1–5

Overview

The Conext XW+ is a modular building block sine-wave inverter/charger that can be used for residential and commercial battery based off-grid, grid backup, and grid interactive applications.

The Conext XW+ is a self-contained DC to AC inverter, battery charger, and integrated AC transfer switch. It is configurable in a hybrid system to operate with generators and renewable energy sources. These configurations are capable of extending battery based off-grid/backup autonomy.

Note: The Conext XW+ 5548 NA and Conext XW+ 6848 NA inverter/chargers are designed for operation with single phase, three wire (120 V/240 V) AC sources and should not be connected to a three-phase AC source.

Inside the Box

Conext XW+ Inverter/Charger and System Components

The following system components are included in this package. If any items are missing, contact your authorized dealer.

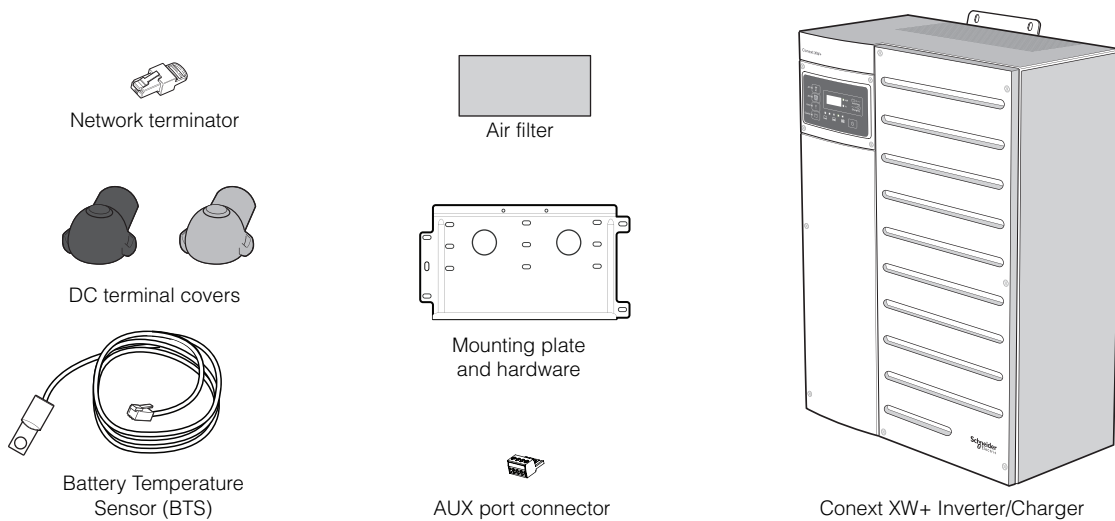

Figure 1-1 Conext XW+ Inverter/Charger and System Components

Battery Temperature Sensor

The Battery Temperature Sensor (BTS) included in this package monitors the temperature of the battery bank and adjusts the charging accordingly. For installation instructions, see “Battery Temperature Sensor Installation” on page 3–10 of this Guide.

Conext XW Jumpers (For Single-Phase Conversion)

Conext XW Jumpers are used to reconfigure a standard Conext XW+ 120 V/240 V, three-wire, split-phase model to accept a 120 V, 2-wire, single-phase connection. Use the jumpers to reconfigure the transformer wires. For more information, see Appendix C, “Split-Phase to Single-Phase Conversion Instructions” in this Guide.

Conext XW+ Features

Front View

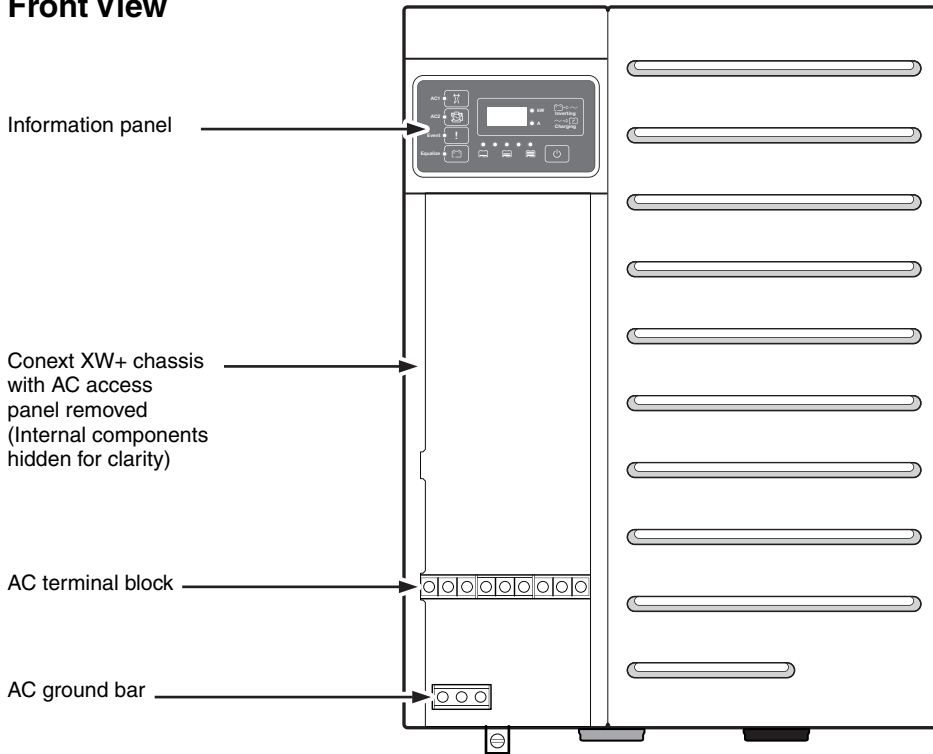

Bottom View

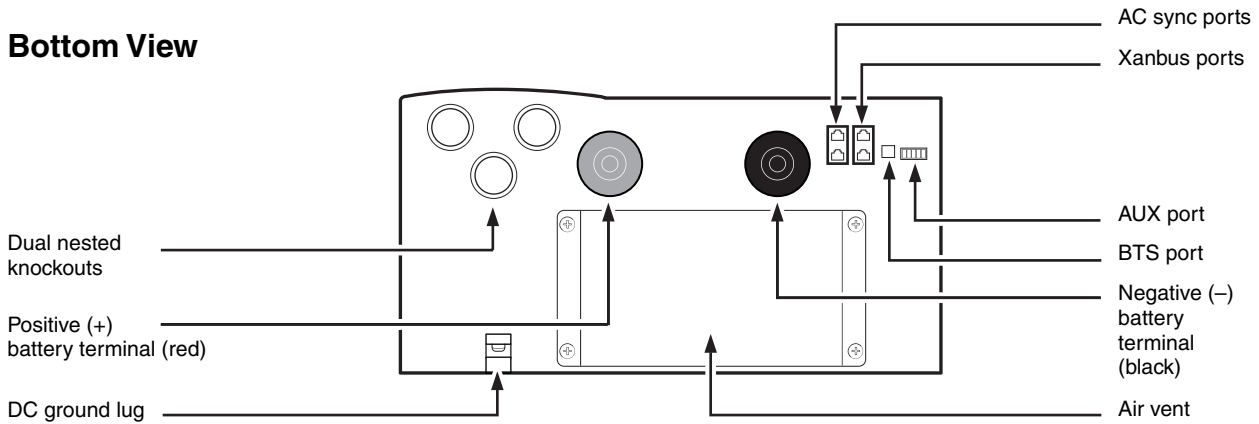

Figure 1-2 Conext XW+ Inverter/Charger Features

Optional Accessories

The following optional accessories are available for the Conext XW+ Inverter/Charger.

For an up-to-date list, call an authorized dealer or visit www.SEsolar.com.

Conext XW+ Conduit Box

Part Number
865-1025-01

The Conext XW+ Conduit Box provides an enclosure over the bottom of the Conext XW+ and covers the cabling that runs underneath.

For installation instructions, see “Installing the Conext XW+ Conduit Box” on page 2–10 of this Guide.

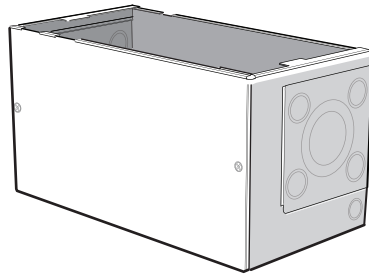

Figure 1-3 Conext XW+ Conduit Box

Note: Your installation may require the inclusion of the Conext XW+ Conduit Box, depending on local electrical code. Consult your local electrical authority to ensure your installation is code-compliant.

Conext XW+ Power Distribution Panel

Part Number
865-1015-01

The Conext XW+ Power Distribution Panel (PDP) is factory wired and labelled with everything to support a single-inverter installation.

Internal wiring and breakers can be added to expand the Conext XW+ with up to three inverters, four charge controllers, or other equipment to support 120/240 volt, three-wire, single-phase systems.

The PDP interfaces with the following Conext products:

- Conext XW+ 5548 NA and Conext XW+ 6848 NA Inverter/Chargers
- Conext MPPT Solar Charge Controllers (breakers and wiring not included)
- C-Series Charge Controllers (breakers and wiring not included).

The Conext XW+ Power Distribution Panel includes the components shown below.

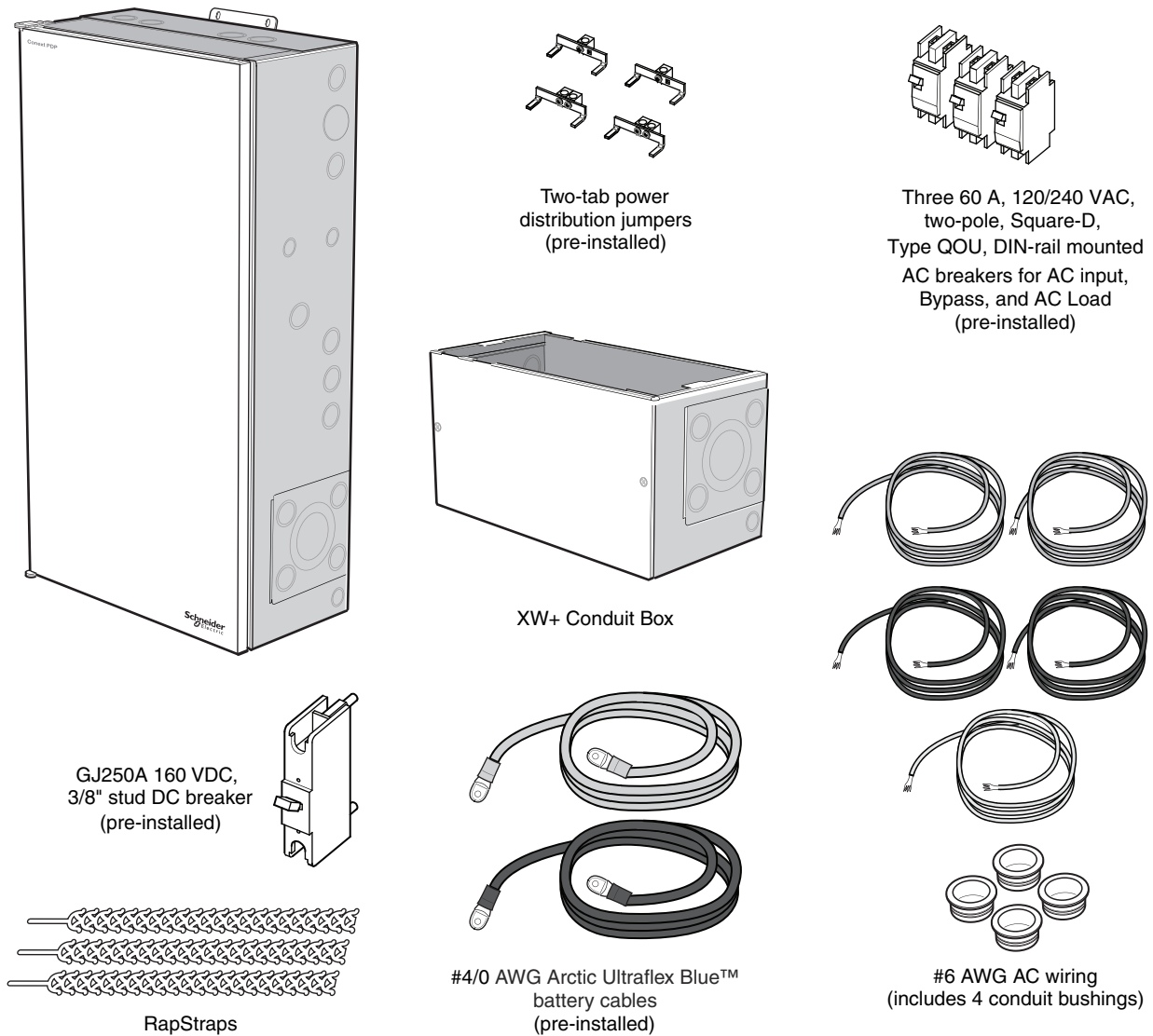

Figure 1-4 Conext XW+ Power Distribution Panel with Conduit Box

Not shown:

- One ground terminal bus bar
- One neutral terminal bus bar
- One battery negative terminal bus bar

Conext XW+ Connection Kit for INV2 INV3 PDP

Part Number
865-1020-01

The Conext XW+ Connection Kit is the extension kit required for connecting a second or third Conext XW+ Inverter/Charger in the same system.

The Conext XW+ Connection Kit includes the components shown below.

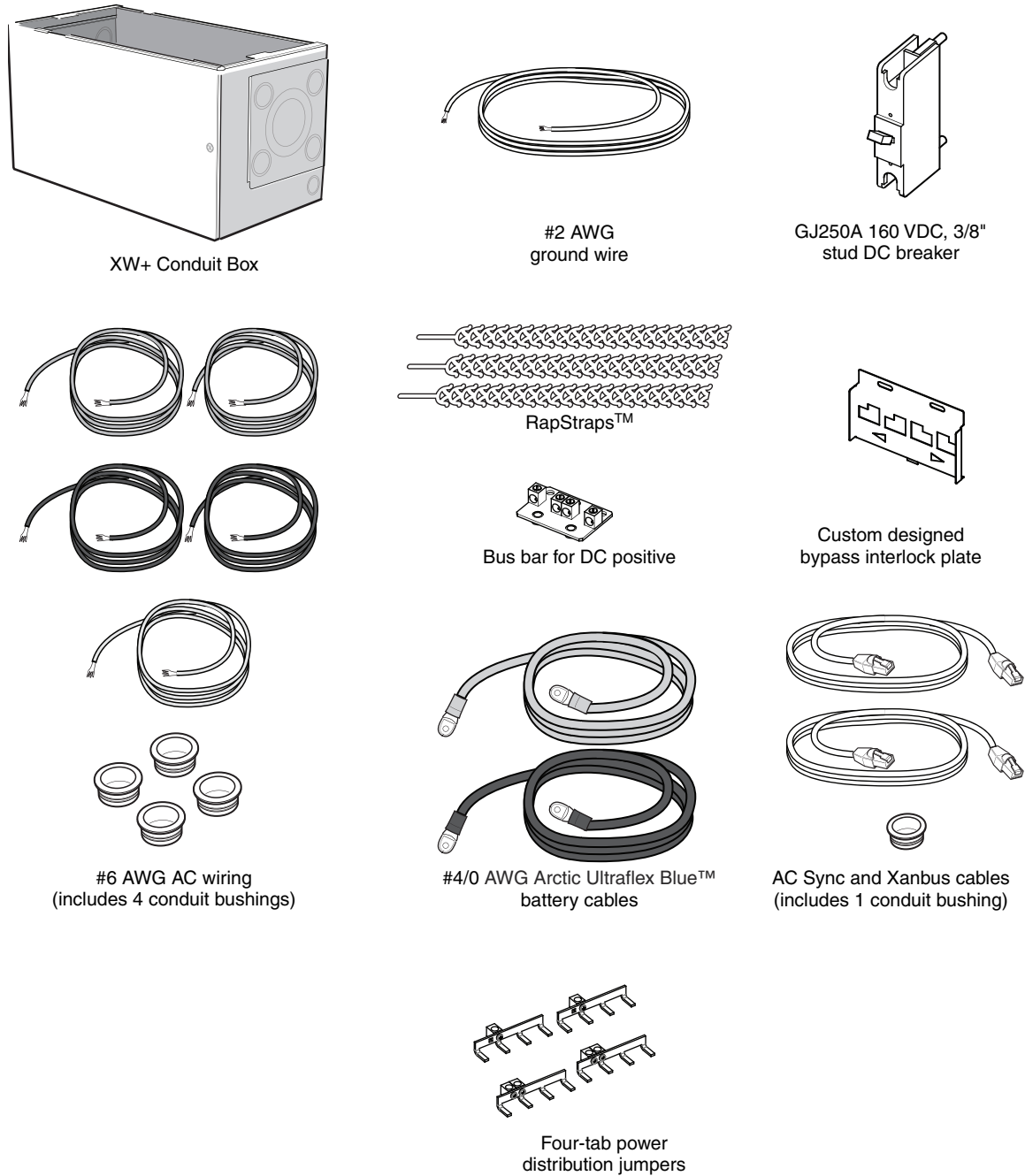

Figure 1-5 Conext XW+ Connection Kit

Conext 120/240VAC Breaker Kit for Conext XW+ PDP

Part Number 865-1215-01 Included: Three 60 A, 120/240 VAC, two-pole, Square-D, type QOU, DIN-rail mountable AC breakers, jumpers, bypass interlock.

Conext MPPT 60 150 Solar Charge Controller

Part Number 865-1030-1 The MPPT 60 150 Solar Charge Controller is a photovoltaic (PV) charge controller that tracks the maximum power point of a PV array to deliver the maximum available current for charging batteries.

For more information, go to www.SEsolar.com.

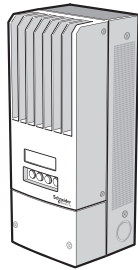

Figure 1-6 Conext MPPT 60 150 Solar Charge Controller

Conext MPPT 80 600 Solar Charge Controller

Part Number 865-1032 The MPPT 80 600 Solar Charge Controller offers an industry-first set of integration features and top performance that allows for large PV array systems to be easily installed and connected to the battery bank at the lowest possible cost.

For more information, go to www.SEsolar.com.

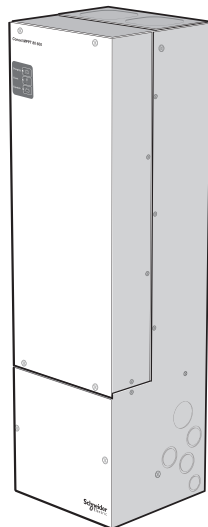

Figure 1-7 Conext MPPT 80 600 Solar Charge Controller

Conext System Control Panel

Part Number
865-1050-01

The Conext System Control Panel (SCP) gives a single point of control to set up and monitor your entire Conext XW+ Inverter/Charger installation.

Featuring a graphical, backlit liquid crystal display, the SCP displays configuration and diagnostic information for devices connected to the network.

For installation instructions, see “Conext XW+ Inverter/Charger Accessories Installation” on page 5-1 of this Guide.

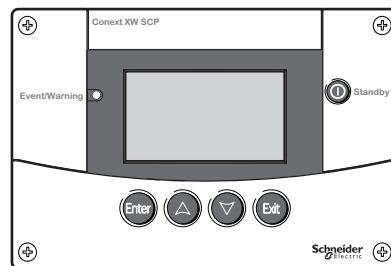

Figure 1-8 Conext System Control Panel

Conext Automatic Generator Start

Part Number
865-1060-01

The Conext Automatic Generator Start (AGS) can automatically start and stop a generator, providing your Conext XW+ Inverter/Charger with power to recharge depleted batteries while powering your loads. The AGS adds intelligence to power management and minimizes time spent monitoring batteries and inverter loads.

For more information, see the *Conext Automatic Generator Start Owner's Guide*.

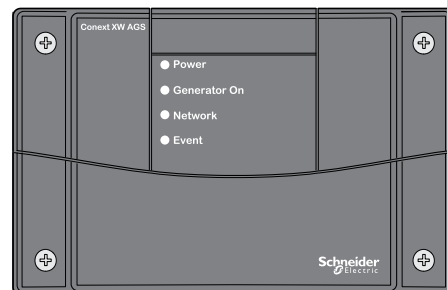

Figure 1-9 Conext Automatic Generator Start

Conext ComBox

Part Number
865-1058

The Conext ComBox Communication and Monitoring Device is a multi-function communication device that enables monitoring of system performance through a PC or the Internet.

It also acts as a communications gateway between a network of Xanbus™-enabled devices and Modbus devices.

For more information, see the *Conext ComBox Owner's Guide*.

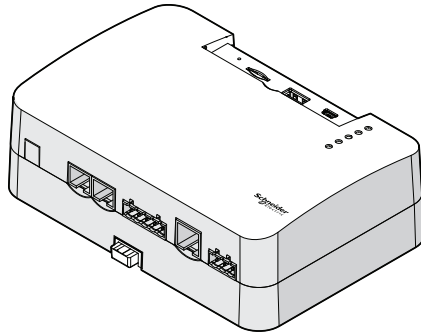

Figure 1-10 Conext ComBox

Conext Battery Monitor

Part Number
865-1080-01

The Battery Monitor is Xanbus-enabled, and features a local display to selectively show the estimated operating voltage, current, consumed amp-hours, remaining capacity and remaining hours in your 48 V battery bank.

For more information, see the *Conext Battery Monitor Quick Start Guide*.

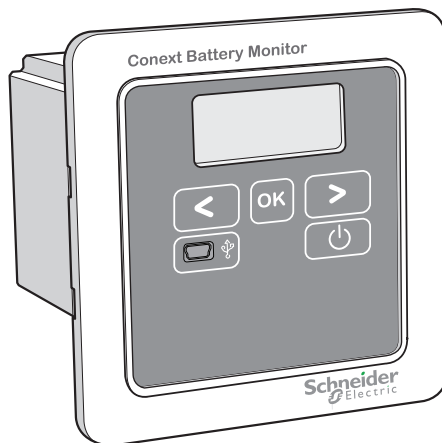

Figure 1-11 Conext Battery Monitor

Conext 3 Phase Breaker Kit for Conext XW+ PDP

Part Number Included: Three 60 A, 120/208 VAC, one-pole, Square-D, type QOU, DIN-rail
865-1315-01 mountable AC breakers, jumpers, bypass interlock.

100A, 125VDC Breaker Master Pack (12 units)

Part Number
865-1080

80A, 125VDC Breaker Master Pack (12 units)

Part Number
865-1070

60A, 160VDC Breaker Master Pack (48 units)

Part Number
865-1075

250A, 160VDC Breaker Master Pack (6 units)

Part Number
865-1065

2

Pre-Installation and Wall-Mounting

Chapter 2, “Pre-Installation and Wall-Mounting” describes the pre-installation steps, and gives instructions for wall-mounting the Conext XW+, Conext XW+ Power Distribution Panel and Conext XW+ Conduit Box.

Topics in this chapter include:

- “Pre-Installation” on page 2–2
- “Wall-Mounting” on page 2–6
- “Communications Network Preparation” on page 2–12
- “Battery Bank Preparation” on page 2–13
- “Torque Values” on page 2–16

Pre-Installation

Before installing the Conext XW+ Inverter/Charger, read all instructions and cautionary markings in this Guide.

Note: Obtain all necessary permits prior to starting the installation. **Installations must meet all local codes and standards.** Installation of this equipment should only be performed by skilled personnel such as qualified electricians and Certified Renewable Energy (RE) System installers.

⚠ WARNING

HEAVY EQUIPMENT

The Conext XW+ Inverter/Charger weighs approximately 120 lbs. (54 kg). A two-person lift is required. To prevent personal injury, always use proper lifting techniques during installation.

Failure to follow these instructions can result in death or serious injury.

Planning the Installation

- Read this entire chapter before beginning the installation. It is important to plan the installation from beginning to end.
- Assemble all tools and materials needed for the installation.

Installation Tools and Materials

To complete the installation, you will need the following tools:

- Socket wrench, appropriately sized
- Phillips head screwdriver, appropriately sized
- Level

Depending on your installation, additional hardware may be required. The following items are not included with the Conext XW+ Inverter/Charger:

- Battery cables
- Grounding wire: #14 AWG to #2 AWG (1.63mm to 6.54mm)
- Lag bolts to secure the mounting plates
- Screws for mounting the Conduit Box
- Additional wiring to connect the PDP to the inverter load sub-panel and utility grid
- Appropriate materials and hardware for additional wall-mount support

Location

The Conext XW+ is certified for dry, indoor (heated or unheated) installations only.

Locate any electronic equipment susceptible to radio frequency and electromagnetic interference as far away from the inverter as possible.

Fire safety

▲ WARNING

IGNITION AND FIRE HAZARD

This equipment is not ignition protected. To prevent fire or explosion, do not install this product in locations that require ignition-protected equipment. This includes any confined space containing lead acid batteries, or flammable chemicals such as, natural gas (NG), liquid petroleum gas (LPG) or gasoline (Benzine/Petrol).

- Do not install in a confined space with machinery powered by flammable chemicals, or storage tanks, fittings, or other connections between components of fuel or flammable chemical systems.
- Do not install the inverter near readily flammable materials such as cloth, paper, straw, or plastic sheeting. Keep flammable materials a minimum distance of 600 cm (24 in.) from the top surface and 30 cm (12 in.) from either side surface and the front of the Conext XW+ Inverter/Charger.

Failure to follow these instructions can result in death or serious injury.

Clearance Requirements

Provide at least 91 cm (36 in.) of clearance in front of the inverter, and a minimum of 15 cm (6 in.) of clearance at the top and bottom of the inverter for ventilation. Ensure the vents remain unobstructed, and that the Conext XW+ Power Distribution Panel door has adequate room to fully open.

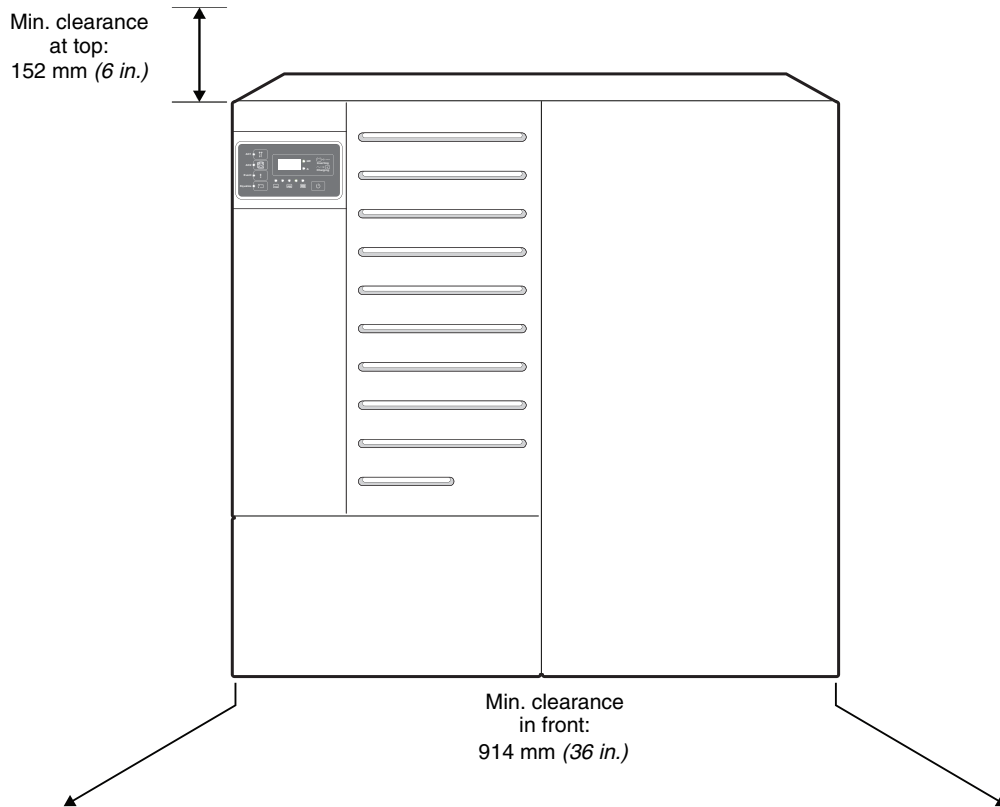

Figure 2-1 Example of clearance requirements for a Conext XW+ with PDP

Knockout Selection

Note: Do not drill, cut, or punch holes into the Conext XW+ Inverter/Charger, Conext XW+ Conduit Box or Conext XW+ Power Distribution Panel. Use only the knockouts provided for conduit entry.

The Conext XW+ Inverter/Charger, Conext XW+ Power Distribution Panel, and Conext XW+ Conduit Box are equipped with nested dual knockouts for wiring through conduits.

Read Chapter 3, "Wiring the Conext XW+ Inverter/Charger and Conext XW+ Power Distribution Panel" and choose the knockouts for your installation.

See Figure 2-2, below, for an example of available knockouts along the top and side of the Conext XW+ Power Distribution Panel.

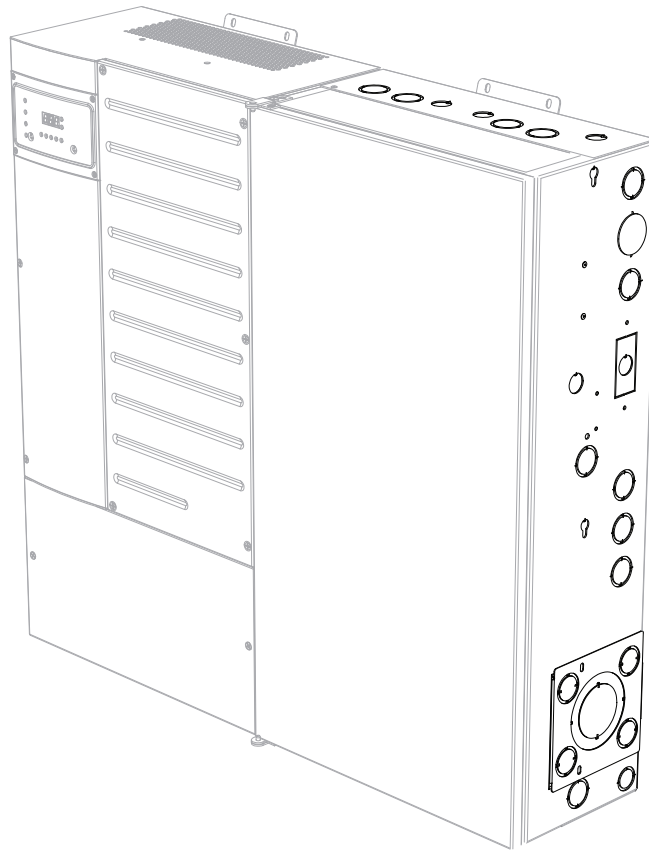

Figure 2-2 Example of available knockouts on the PDP

Remove your choice of knockouts from the Conext XW+ chassis, Conext XW+ Conduit Box, and/or Conext XW+ Power Distribution Panel. Ensure that no debris remains inside the chassis. Insert appropriately-sized conduit bushings into each conduit hole.

Air Filter and AUX Port Connector Installation

Insert the air filter by tucking it into the grooves on the sides of the air vent cover (See Figure 2-3.)

If you are planning to use the auxiliary (AUX) port features, insert the AUX port connector into the AUX port. (See Figure 2-3.)

For more information, see “AUX Port” on page 3–5 of this Guide.

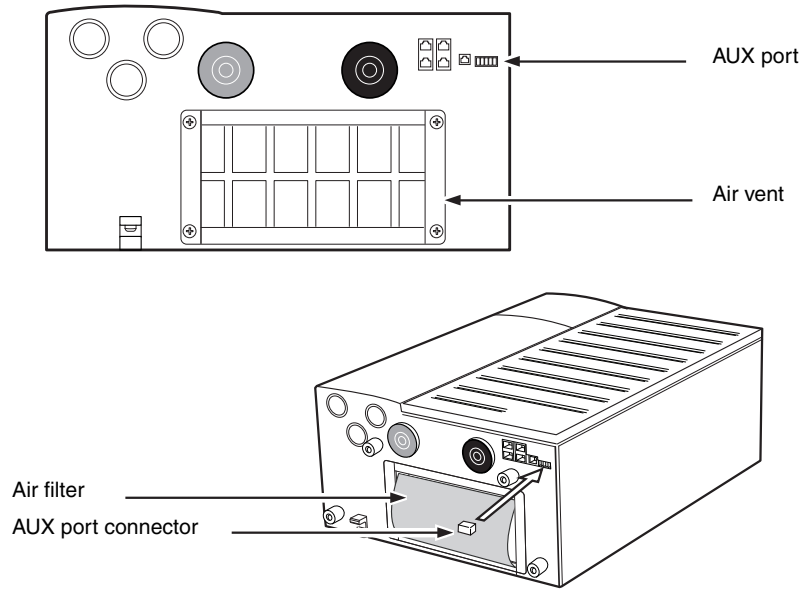

Figure 2-3 Air Filter and AUX Port Connector Installation

Wall-Mounting

⚠ WARNING

HEAVY EQUIPMENT

The Conext XW+ Inverter/Charger can cause serious injury if it falls or is dropped on a person.

For structural and seismic stability, the Conext XW+ Inverter/Charger must be mounted onto a vertical supporting surface strong enough to support a minimum of 500 lbs. (227 kg).

Failure to follow these instructions can result in death or serious injury.

A mounting plate is included with each Conext XW+ Inverter/Charger and Conext XW+ Power Distribution Panel (PDP), designed to meet standards for structural and seismic stability. When properly installed, the system also meets Section 59 of UL 1741 for Static Loads.

Each Conext XW+ and PDP requires a separate mounting plate. Attach the mounting plate to the wall before you attach the Conext XW+ or PDP to the mounting plate.

Each mounting plate requires a minimum of four 1/4-inch diameter lag bolts or other fasteners (not included). The fasteners must be strong enough to support 500 lbs (227 kg).

The type of fastener required to secure the mounting plate varies according to the vertical surface and wall structure of your installation location. For a list of recommended fasteners, see Table 2-1, below.

Table 2-1 Recommended fasteners

Structure	Required Fastener	Screws Per Plate
Wood studs at 16" on-center (O.C.)	1/4" Ø × 3 1/2" long lag screw	Four
Wood studs not at 16" O.C. (3/4" minimum plywood panel required)	1/4" Ø × 1" long wood screw	Six
Steel studs at 16" O.C. (minimum 18 gauge)	1/4" Ø self-drilling screw	Four

The holes of each mounting plate are spaced 16 inches (40 cm) apart, so that the mounting plate will span two wall studs spaced 16 inches on-center. Additional mounting holes are provided to allow for other mounting options.

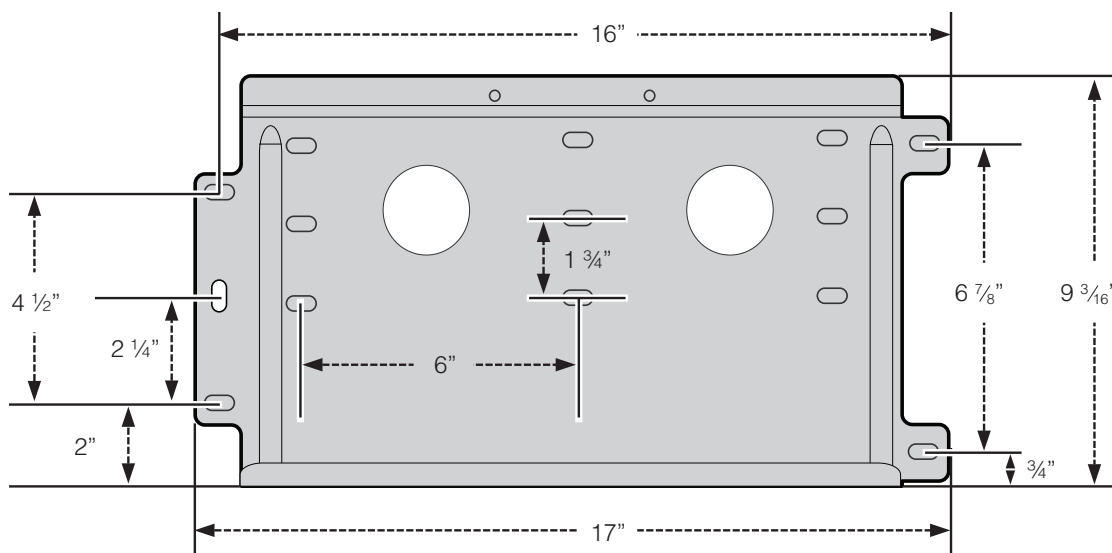

Figure 2-4 Mounting plate dimensions

Note: If the wall does not have 16-inch (40 cm) on-center studs, you will need to provide adequate support for the mounting plates. For example, a sheet of plywood can be attached to the wall, and the mounting plates can then be attached to plywood.

Installing the Mounting Plate

To install the mounting plate:

1. Locate the wall studs.
2. If necessary, secure a $\frac{3}{4}$ " plywood panel or other appropriate additional support panel to the wall studs. The additional support panel must span at least three wall studs.

Note: To secure the additional support panel to the wall, use hardware sized to support a minimum of 500 lbs. (227 kg). (Hardware not included.)

3. Using a level, secure the first mounting bracket to the wall. Ensure the mounting plate is centered on the wall studs, as shown in Figure 2-5. Use recommended anchoring hardware to secure the plate (see Table 2-1).

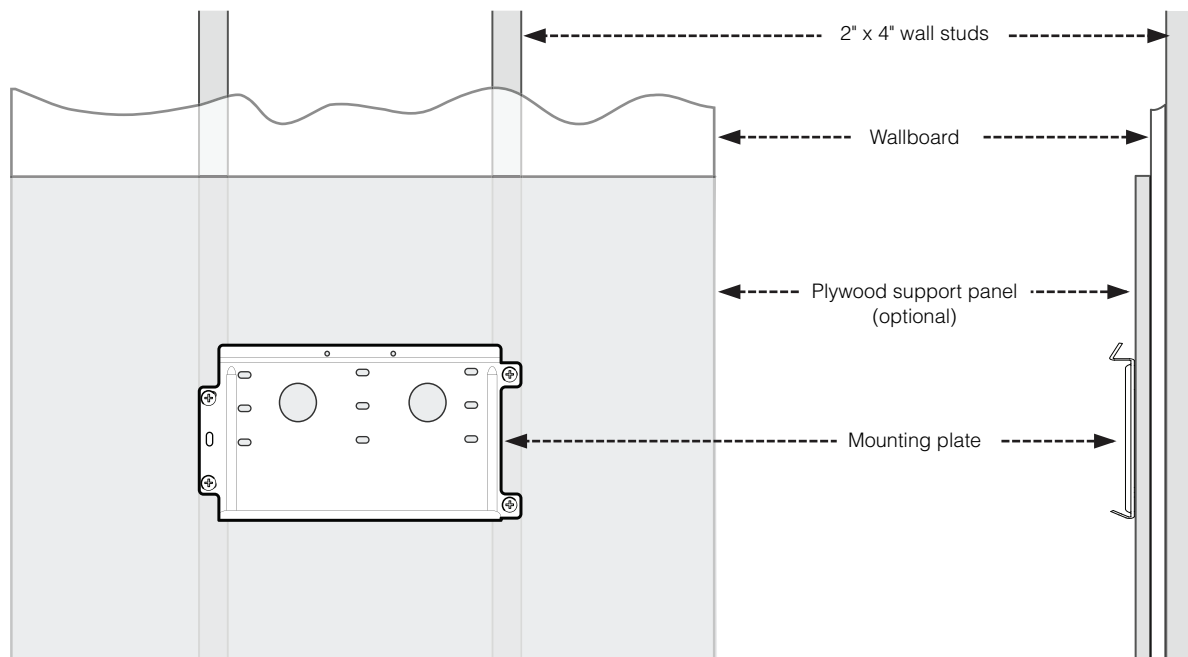

Figure 2-5 Mounting plate centered on wall studs

Installation tip

If you install the bottom of the mounting plate at 60" (152 cm) from floor, the inverter information panel will be approximately 65" from the floor.

4. Install additional mounting plates adjacent to each other as needed.

Note: The mounting plates are designed to interlock (as shown in Figure 2-5, so that multiple plates can be installed without additional measuring or leveling).

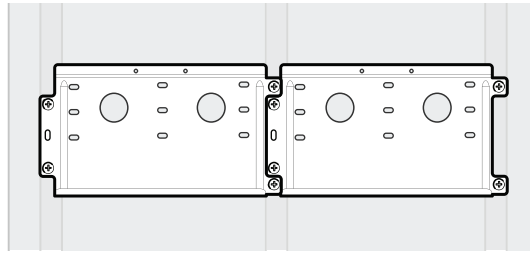

Figure 2-6 Two interlocking mounting plates

Wall-Mounting the Conext XW+ and PDP

To wall-mount the Conext XW+ Inverter/Charger:

1. Align the flange on the back of the Conext XW+ chassis with the bottom edge of the mounting plate, as shown in Figure 2-7.

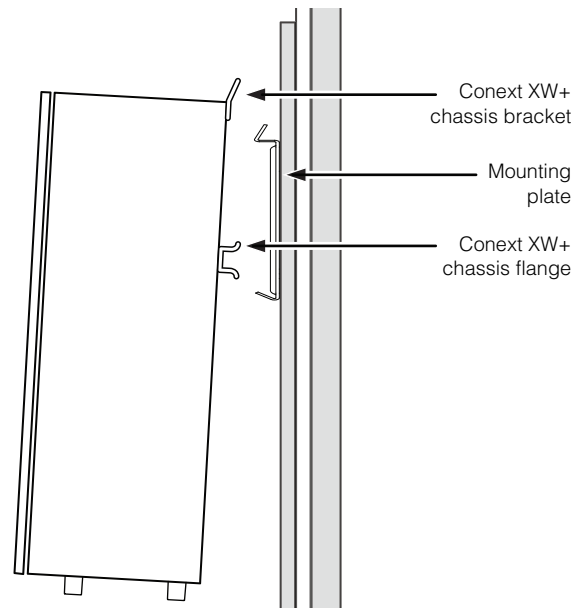

Figure 2-7 Wall-mounting the Conext XW+

▲ WARNING

HEAVY EQUIPMENT

The Conext XW+ Inverter/Charger weighs approximately 120 lbs. (54 kg). A two-person lift is required. To prevent personal injury, always use proper lifting techniques during installation.

Failure to follow these instructions can result in death or serious injury.

2. Lower the Conext XW+ chassis flange onto the mounting plate.
3. Secure the bracket at the top of the Conext XW+ chassis with two #10 self-tapping screws (included).
4. Wall-mount the PDP and any additional Conext XW+ Inverter/Chargers using the same procedure shown in steps 1-3 (above).

Installation tip

The PDP is designed to mount on the right side of the inverter/charger, but it can be configured to mount on the left side instead. For more information, see the *Conext XW+ Power Distribution Panel Installation Guide*.

Installing the Conext XW+ Conduit Box

The Conext XW+ Conduit Box is divided into two parts: the rear panel and the front panel.

To secure the Conduit Box to the Conext XW+ chassis:

1. Remove both #10 screws from the bottom of the Conext XW+ chassis.
2. Find the keyhole slots located under the top of the rear panel.
3. Align the keyhole slots on the top panel of the Conduit Box with the corresponding #10 screws on the bottom of the inverter.

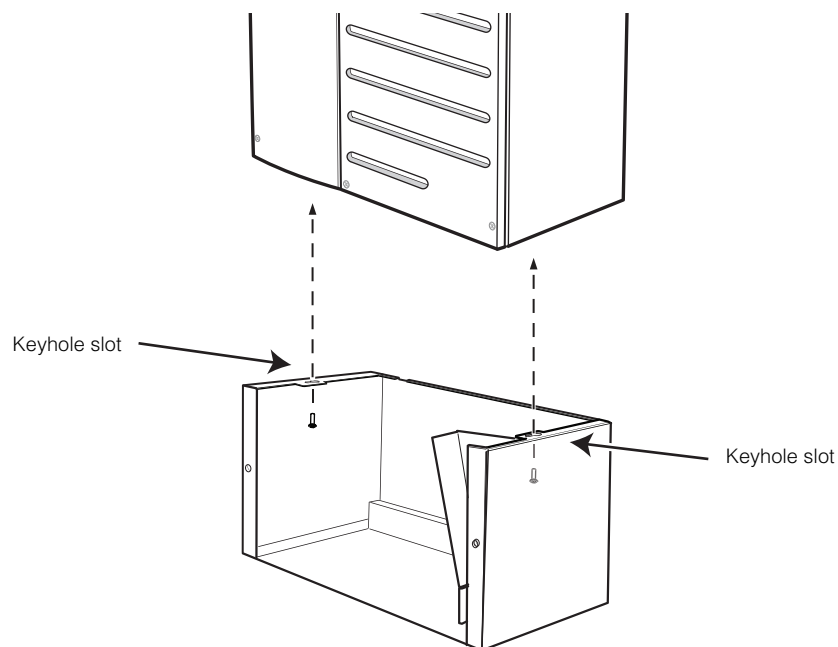

Figure 2-8 Conduit Box keyhole alignment

4. Secure the Conduit Box to the inverter with the both #10 screws.

- Using two screws (not included), secure the bracket at the bottom edge of the rear panel to the wall. See Figure 2-9.

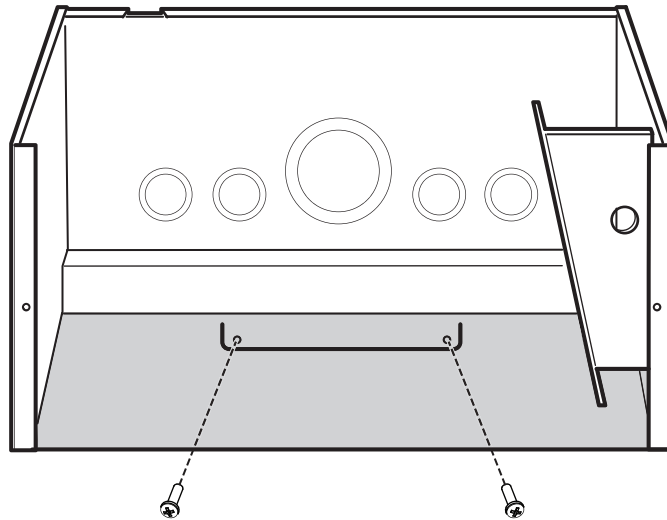

Figure 2-9 Wall-mounting the Conduit Box

Installation tip

Do not secure the front panel of the Conduit Box until you have completed all wiring.

To secure the front panel of the Conduit Box:

- Slide the bottom lip of the front panel over the lower edge of the rear panel.
- Align the two holes in the front panel with the two holes in the back panel.
- Using two #10-32 screws (included), secure the front panel to the rear panel.

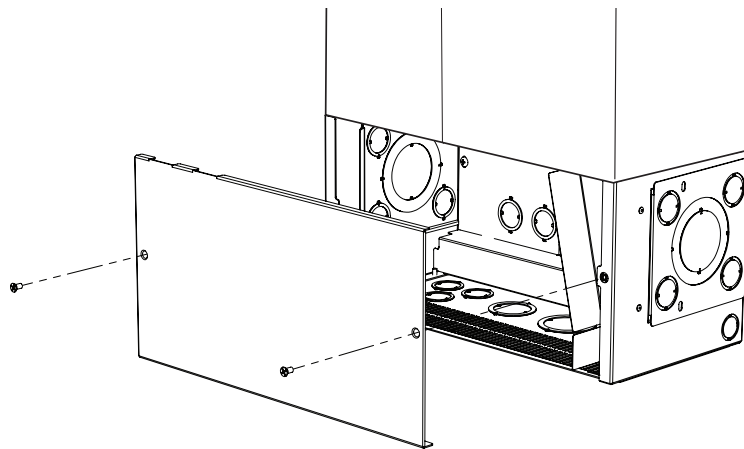

Figure 2-10 Conduit Box installation

Communications Network Preparation

⚠ WARNING

XANBUS SHOCK HAZARD

Xanbus cables in contact with DC or AC power can transmit an electric shock. Do not route the Xanbus cables in the same conduit or panel as the AC and DC power cabling.

Failure to follow these instructions can result in death or serious injury.

To separate the communications cables and signal cables from the DC and AC wiring, a raceway (wire barrier) has been included in the design of both the Conext XW+ Power Distribution Panel and the Conext XW+ Conduit Box.

This raceway is built into the bottom of the Conext XW+ Power Distribution Panel and Conext XW+ Conduit Box (see Figure 2-11, below) and is held in place by a single screw at the top of each raceway.

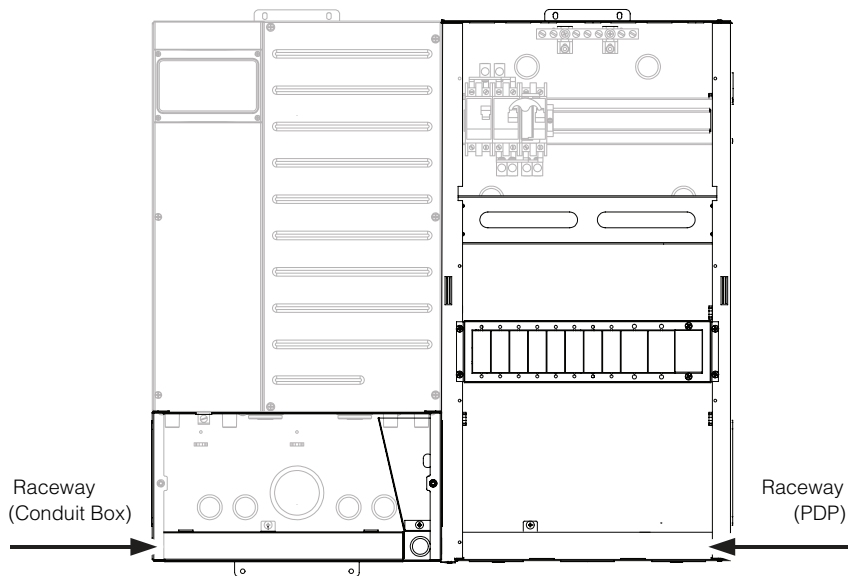

Figure 2-11 Example of raceways in a single-inverter system

Before making AC and DC connections, route communication cables (including Battery Temperature Sensor) through the raceways. For easier identification, use a different color for each communications cable, or cable tags.

Connect communications cables to their components after AC and DC connections are made.

Battery Bank Preparation

▲ WARNING

BATTERY TYPE AND SET UP HAZARDS

Incorrect battery configurations or settings for battery types can lead to dangerously high battery temperature, fire and explosion.

To avoid damaging your batteries during charging or equalization, and to minimize the risk of fire or explosion consult battery manufacture's documentation before setting battery parameters and follow the battery manufacturer's recommended settings.

- Always use and connect the Battery Temperature Sensor (BTS).
- Always verify that the configured battery type matches the battery type being used.
- Custom battery settings should be configured by qualified personnel only.
- When using Lithium-Ion batteries, ensure that the battery pack being used includes a Battery Management System (BMS) with safety controls.
- Do not use wet type Lithium-Ion batteries.

Failure to follow these instructions can result in death or serious injury.

The Conext XW+ Inverter/Charger operates with batteries as its source of DC power. If DC power sources are connected directly to the inverter, the DC rating of the inverter can be exceeded and the inverter can be damaged.

NOTICE

OTHER SOURCES OF DC POWER

Do not connect DC power sources, such as PV arrays, wind turbines, or micro-hydro turbines, directly to the Conext XW+ Inverter/Charger. Connect DC power sources to a charge controller and then to the battery. DC surge protection should also be installed.

Failure to follow these instructions can result in damage to equipment.

Choose Flooded, AGM, Gel, Lithium-Ion, or custom batteries for your installation.

Consider the following recommendations for battery use:

- Use only deep cycle types for inverter applications.
- Use the same battery type for all batteries in the bank.
- Use only batteries from the same lot and date in your battery bank. This information is usually printed on a label located on the battery.

Battery Bank Requirements

The DC voltage of the Conext XW+ Inverter/Charger must match the nominal voltage of the system and battery-connected devices. The inverter is a 48 V inverter; therefore, the battery bank and battery-connected devices in the system must be configured for 48 volts.

Note: The minimum recommended battery bank is 440 Ah per inverter/charger. The Conext XW+ Inverter/Charger is designed to operate with batteries and should not be operated without them. Also, do not allow the battery bank to become completely discharged. If the voltage of the battery bank falls below 10 volts, the Conext XW+ Inverter/Charger will not operate.

Battery Cable Requirements

⚠ WARNING

OVERHEATING OF DC TERMINALS AND CABLES

Overheating of the DC terminals or DC cables to dangerous temperatures may occur due to improper installation.

- Do not put anything between the cable lug and the terminal surface.
- Do not over-tighten connections; observe all recommended torque values.
- Do not apply any type of anti-oxidant paste until after the cable connection is tightened.
- Do not under size cables; install cables sized in accordance with national electrical code requirements.
- DC cables must have crimped copper compression lugs or crimped and soldered copper compression lugs; soldered connections alone are not acceptable. Lugs must be rated for use with fine-stranded cable.
- Do not use coarse-stranded cable; the lack of flexibility may pull DC terminal connections loose.

Failure to follow these instructions can result in death or serious injury.

Battery cable length

Cable runs should be kept as short as practical. Length should not exceed 10 feet (3 m). Run the positive and negative cables alongside each other. Avoid cable loops.

In order to keep the battery cable length short, install the Conext XW+ Inverter/Charger as close as possible to the battery room or battery enclosure.

Note: For best system performance, ensure that positive and negative battery cables are installed in close proximity to each other.

Overcurrent protection

▲ WARNING
<p>DC OVER CURRENT</p> <p>The NEC/CEC requires both DC over current protection and a DC disconnect switch for residential and commercial electrical systems. Fuses and disconnects must be sized to protect the wiring in the system and are required to open before the wire reaches its maximum current carrying capability.</p> <p>Failure to follow these instructions can result in death or serious injury.</p>

Terminal covers

Color-coded snap-on DC terminal covers are included to avoid accidental contact with the terminals. Terminal covers are required for all installations, even if a Conext XW+ Conduit Box is used. It is also recommended that the shank of the ring terminals (cable lugs) be covered with heat shrink or some other form of insulation.

Note: The NEC/CEC requires both overcurrent protection and a disconnect switch for residential and commercial electrical systems. These items are not supplied as part of the inverter, but are included with the Conext XW+ Power Distribution Panel.

Table 2-2 Recommended Battery Cable Size Versus Length

Inverter Model	Up to 5 Feet (1.5 m) (90°C wire)	Up to 10 Feet (3 m) (90°C wire)
Conext XW+ 5548 NA	#2/0 AWG (70 mm ²)	#4/0 AWG (120 mm ²)
Conext XW+ 6848 NA	#4/0 AWG (120 mm ²)	#4/0 AWG (120 mm ²)

Table 2-3 Battery Cable (in Conduit) to Maximum Breaker/Fuse Size

Cable Size Required	Maximum Breaker/Fuse Size
#2/0 (00) AWG (70 mm ²)	175 amps
#4/0 (0000) AWG (120 mm ²)	250 amps

Torque Values

Torque values for the Conext XW+

Table 2-4 Torque Values for AC Wiring (AC Terminals and Ground Bar)

Wire Size		Torque Value	
AWG	mm	In-lb	N-m
14–10	1.63–2.59	35	4.0
8	3.26	40	4.5
6–4	4.11–5.19	45	5.1

Table 2-5 Torque Values for the Chassis Ground Lug

Wire Size		Torque Value	
AWG	mm	In-lbs	N-m
6–4	4.11–5.19	45	5.1
3–2	5.83–6.54	50	5.6

Table 2-6 Torque Values for the Inverter Battery Terminals

Torque Value	
Ft-lbs	N-m
15	20.4

Torque Values for the Conext XW+ Power Distribution Panel

Table 2-7 Torque Values for AC Disconnects and AC Breakers

Wire Size		Torque Value	
AWG	mm	In-lb	N-m
16–10	1.29–2.59	45	5.1
8	3.26	45	5.1
6–4	4.11–5.19	45	5.1

Table 2-8 Torque Values for the Ground Bus, AC Neutral Bus, DC Negative Bus, and DC Positive Bus in the Conext XW+ Power Distribution Panel

Wire Size		Torque Value	
AWG	mm	In-lbs	N-m
14–10	1.63–2.59	35	4.0
8	3.26	40	4.5
6–4	4.11–5.19	45	5.1
3–2/0	5.83–9.27	50	5.6

Table 2-9 Torque Values for the power distribution jumpers in the Conext XW+ Power Distribution Panel

Wire Size		Torque Value	
AWG	mm	In-lbs	N-m
14-10	1.63-2.59	35	4.0
8	3.26	40	4.5
6-4	4.11-5.19	45	5.1
3-2/0	5.83-9.27	50	5.6

Table 2-10 Torque Values for the Battery Cables to the DC Negative Bus, and DC Positive Bus in the Conext XW+ Power Distribution Panel

Torque Value	
Ft-lbs	N-m
15	20.4

3

Wiring the Conext XW+ Inverter/Charger and Conext XW+ Power Distribution Panel

Chapter 3, “Wiring the Conext XW+ Inverter/Charger and Conext XW+ Power Distribution Panel” describes procedures for installing the Conext XW+ Inverter/Charger.

Topics in this chapter include:

- “Removing the AC Access Panel and PDP Internal Faceplates” on page 3–2
- “Wiring the Conext XW+ Inverter/Charger with a PDP” on page 3–7
- “Wiring Additional Conext XW+ units with a PDP” on page 3–37
- “Wiring a Balanced Three-Phase System” on page 3–56
- “Wiring the Conext XW+ Inverter/Charger without a PDP” on page 3–67

Removing the AC Access Panel and PDP Internal Faceplates

AC Access Panel Removal

⚠ DANGER

HAZARD OF ELECTRIC SHOCK, EXPLOSION, OR ARC FLASH

- Apply appropriate personal protective equipment (PPE) and follow safe electrical work practices. See NFPA 70E or CSA Z462.
- This equipment must only be installed and serviced by qualified electrical personnel.
- Never operate energized with covers removed
- Energized from multiple sources. Before removing covers identify all sources, de-energize, lock-out, and tag-out and wait 2 minutes for circuits to discharge
- Always use a properly rated voltage sensing device to confirm all circuits are de-energized.

Failure to follow these instructions will result in death or serious injury.

⚠ DANGER

HAZARD OF ELECTRIC SHOCK, EXPLOSION, OR ARC FLASH

- Remove watches, rings, or other metal objects.
- This equipment must only be installed and serviced by qualified electrical personnel.
- Keep sparks and flames away from the batteries.
- Use tools with insulated handles.
- Wear protective glasses, gloves and boots.
- Do not lay tools or other metal parts on top of batteries.

Failure to follow these instructions will result in death or serious injury.

▲ DANGER

HAZARD OF ELECTRIC SHOCK, EXPLOSION, OR ARC FLASH

- Battery Circuit Breakers must be installed according to the specifications and requirements defined by Schneider Electric.
- Servicing of batteries must only be performed by qualified personnel knowledgeable of batteries and the required precautions. Keep unqualified personnel away from batteries.
- Disconnect the charging source prior to connecting or disconnecting battery terminals.

Failure to follow these instructions will result in death or serious injury.

To access the AC terminal block on the Conext XW+ for AC wiring, you will need to remove the AC access panel, located below the inverter information panel on the left side of the Conext XW+ chassis.

To remove the AC access panel, remove the two screws from the AC access cover and slide the cover slightly to the left and lift away from the Conext XW+ chassis.

Installation tip

When re-securing the AC access cover, ensure its recessed edge slips inside the edge of the front panel.

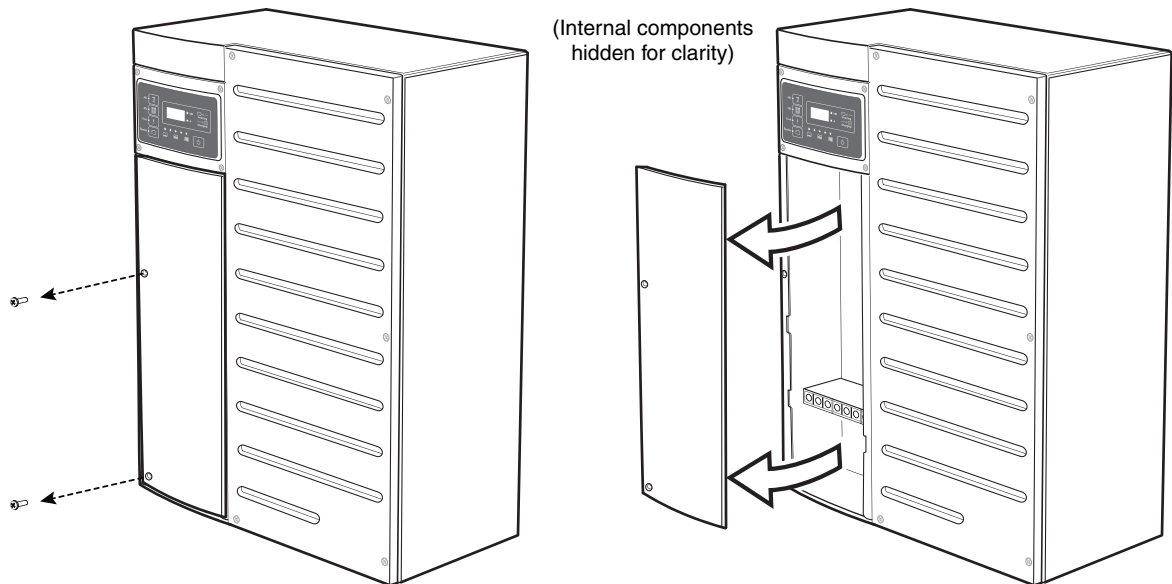

Figure 3-1 AC access panel removal

Conext XW+ Power Distribution Panel Internal Faceplate Removal

If you are wiring the Conext XW+ Inverter/Charger to a Conext XW+ Power Distribution Panel (PDP), you will need to remove the two front faceplates from the PDP.

For easier access to the faceplates, begin by removing the panel door from its hinges.

To remove the PDP door:

1. Remove the screw at the top hinge of the PDP door and remove the top section of the hinge.
2. Using your thumb or forefinger, gently pivot the hinge upward as you remove the PDP door.

To remove the PDP faceplates:

1. Remove the four screws holding the upper faceplate in place.
2. Remove the four screws holding the lower faceplate in place.

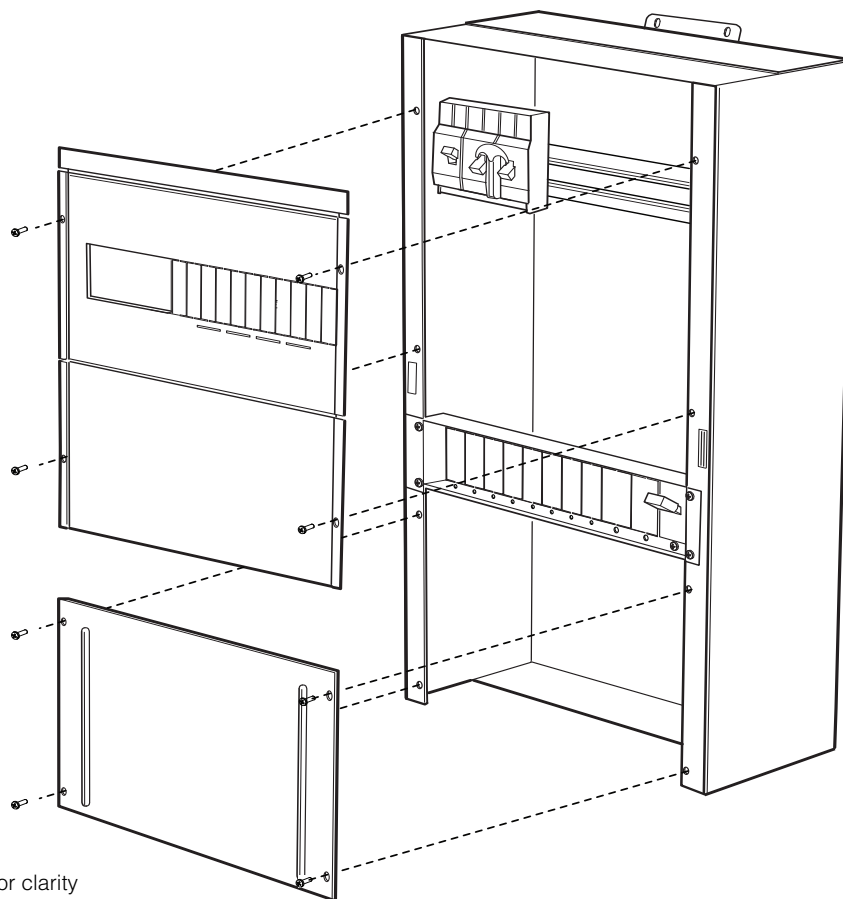

Figure 3-2 Conext XW+ Power Distribution Panel faceplate removal

Communication Ports and BTS Port

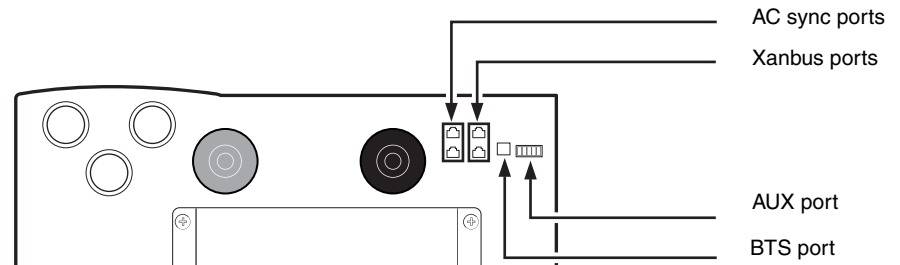

Figure 3-3 Conext XW+ Inverter/Charger communication ports

There are five communication ports and a Battery Temperature Sensor (BTS) port located on the bottom of the Conext XW+ chassis (as shown above in Figure 3-3):

- Two Xanbus ports for making network connections between inverters, charge controllers, and accessories. For more information, see Chapter 4, “Xanbus Network Installation”.
- Two AC sync ports to connect multiple Conext XW+ Inverter/Chargers in parallel. For installation instructions, see “Installing AC sync and Xanbus cables” on page 4–5.
- AUX port: 12 VDC/250 mA output to control a relay, fan, indicator light, or other device, using a Conext System Control Panel (SCP) or Conext ComBox. For more information, see “AUX Port” on page 3–5.
- Battery Temperature Sensor (BTS) port: For more information, see “Battery Temperature Sensor Installation” on page 3–10.

AUX Port

The Conext XW+ Inverter/Charger has a 12 VDC auxiliary (AUX) output that can be configured to trigger in response to one of the following conditions:

- low battery voltage
- high battery voltage
- low battery temperature
- high battery temperature
- charge bulk exit
- charge absorption exit
- heatsink temperature
- TOD (time of day)

The auxiliary output can also be triggered manually using a Conext System Control Panel or ComBox.

Note: The AUX port is connected via an AUX port connector, included with the Conext XW+ Inverter/Charger.

The 12 VDC output can be used to trigger a relay to disconnect batteries from the inverter/charger when battery voltage or temperature are out of range.

The auxiliary output is also designed to provide the following functions:

- Auxiliary 12 VDC power supply. See AUX+12V Voltage Supply, below.
- Remote Power Off. See AUX-RPO: User Remote Power OFF (RPO), below.

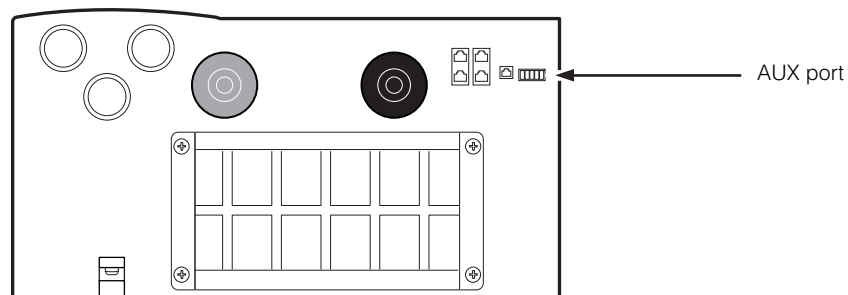

Figure 3-4 AUX Port Location

AUX+12V Voltage Supply

DC voltage is available between JU-1 (AUX +12 V) and JU-3 (AUX-COM, signal return). The power available at these terminals is 12 VDC and maximum current is 250 mA (3 watts).

AUX+12 V and AUX-COM terminals can be used to power a relay (3 watts maximum).

Note: Additional fuses may be necessary for some installations.

AUX +12 V voltage supply can be programmed for different tasks ON and OFF using the Conext System Control Panel.

Default status of AUX+12 V is OFF.

AUX-RPO: User Remote Power OFF (RPO)

Connecting JU-2 (AUX-RPO) and JU-3 (AUX-COM) terminals together through an external switch (normal open contact) will provide the system shut off function if the switch is closed. The external switch, if pressed, overrides the control provided from the front panel.

To enable the AUX port remote power off function, enable the RPO setting from the System Control Panel. For more information, see the *Conext XW+ Inverter/Charger Owner's Guide*. If the external switch is cleared (not pressed), the system can be enabled back from the front panel.

Select an external switch with normal open contact; consult your local system designer or qualified technician for specific installation instructions.

User Line Wiring

Use twisted pairs of #24 AWG to #12 AWG (0.51mm to 2.05mm) for connections. Carefully route the wires away from high power load cables to minimize noise effects on signal integrity.

AUX Port Terminal Assignments

Table 3-1 User Connector Terminals and Functions

Pin	Reference	Name	Function
JU-1	AUX+12V	+12 V User Voltage Supply	+12 VDC Voltage source: 250 mA maximum
JU-2	AUX-RPO	Remote Power Off	Remote Power Off Logic Level: Active Low. Activating this signal shuts down system operation.
JU-3	AUX-COM	Common Ground Reference	Return Common Ground Reference for 12 V, Remote Power Off signals.
JU-4	EXT_TS_OUT	External Transfer switch: Output signal	Open collector type drive circuit (30V/0.5A max)
JU-5	EXT_TS_IN	External Transfer switch: Input signal	External Transfer switch: Low signal range:(0-5V) High signal range:10-28V with the consumption of 8mA@12V and 10mA@24V.

Wiring the Conext XW+ Inverter/Charger with a PDP

NOTICE

OVERLOADING THE DISTRIBUTION PANEL

The amount of power that can be fed into a distribution panel and the means and location for feed-in, must be in accordance with NEC 2008 article 690.64 or the current requirements of the local electrical code.

Failure to follow these instructions can result in damage to equipment.

This section provides instructions for making AC and DC connections between the Conext XW+ Inverter/Charger and an Conext XW+ Power Distribution Panel (PDP), using a Conext XW+ Conduit Box and the pre-installed cables in the PDP.

To install a Conext XW+ without the Conext XW+ Conduit Box or PDP, see “Wiring the Conext XW+ Inverter/Charger without a PDP” on page 3–67 of this Guide.

Note: If a Conext XW+ Conduit Box is installed, run the communication and Battery Temperature Sensor cables through the raceway at the rear of the Conext XW+ Conduit Box and PDP before making AC and DC connections. The raceways become more difficult to access after AC and DC wiring is completed. For more information, see “Communications Network Preparation” on page 2–12 of this Guide.

Conext XW+ Inverter/Charger Grounding

⚠ WARNING

UNGROUNDING EQUIPMENT

Equipment ground terminals must be reliably connected to ground by appropriately sized grounding conductors. All installations must comply with national and local codes. Consult local and national codes for specific grounding and bonding requirements.

Failure to follow these instructions can result in death or serious injury.

The Conext XW+ is provided with ground terminals that must be reliably connected to ground (protective earth) by appropriately sized equipment grounding conductors. System grounding for the AC and DC systems must be done according to all applicable NEC and local installation codes.

For more information about system grounding, see “Grounding the DC System” on page 3–8 and “AC Equipment Grounding” on page 3–20.

Grounding the DC System

To connect the Conext XW+ to the DC grounding system, use the ground lug at the bottom of the Conext XW+ chassis (see “Conext XW+ Features” on page 1–4). The terminal accepts wires from #14 AWG (1.63 mm) to #2 AWG (6.54 mm).

System grounding for the DC system, which typically involves bonding (connecting) the battery negative circuit to ground, is dependent on the system configuration.

Note: If a grounded DC system is required, ensure that the system bonding is done in one location only, and that all conductors and connections comply with all applicable NEC and local installation codes.

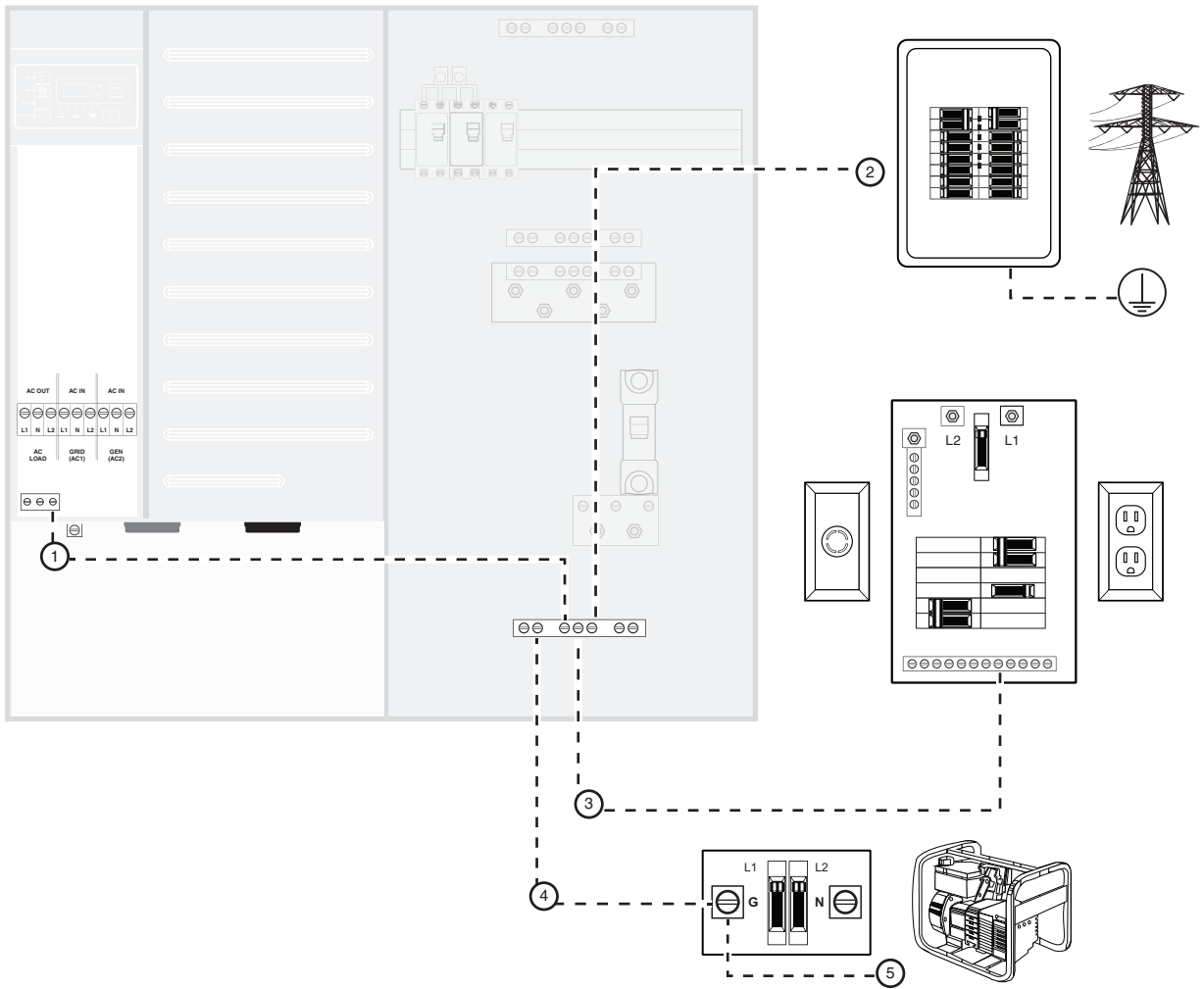

DC Terminal Connections

1. To AC ground bar

Note: May not be required if DC ground is used instead.

2. To main utility panel

3. To inverter load sub-panel

4. To generator disconnect

Note: Depending on the location of the generator and local code requirements, the generator disconnect may be located in the power distribution panel.

5. To AC generator

Grounding requirements may vary.

Cable routing may vary. See Knockout Selection on page 2-5 and Communications Network Preparation on page 2-12.

For torque values, see page 2-16 and 2-17.

Figure 3-5 DC Grounding Using a Conext XW+ Power Distribution Panel

Battery Temperature Sensor Installation

⚠ WARNING

BATTERY TEMPERATURE

The Battery Temperature Sensor provides necessary information for performance and safety.

Always install and connect the Battery Temperature Sensor (BTS).

Failure to follow these instructions can result in death or serious injury.

The Battery Temperature Sensor (BTS) regulates battery charging based on battery temperature. The BTS extends battery life by minimizing overcharging in warm temperatures and undercharging in cold temperatures.

The BTS connects to the Conext XW+ via the BTS port, which is located at the bottom of the Conext XW+ chassis, next to the communication ports.

Note: Connect the BTS to the batteries only after the battery bank has been prepared and is ready to connect to the inverter.

To install the Battery Temperature Sensor:

1. Route the BTS cable through your preferred conduit route and insert the BTS jack into the BTS port.
2. Route the BTS cable to the battery enclosure, and then connect the BTS using one of the following methods (as shown in Figure 3-6 on page 3-11):
 - a) Connect the BTS ring terminal directly to a battery terminal (recommended), or:
 - b) Attach the BTS to any side of the battery you wish to monitor by using the adhesive backing on the BTS.

Note: When using the adhesive backing, install the BTS on the side of the battery below the electrolyte level.

Installation tip

Place the sensor between batteries and place the batteries in an insulated box to reduce the influence of the ambient temperature outside the battery enclosure.

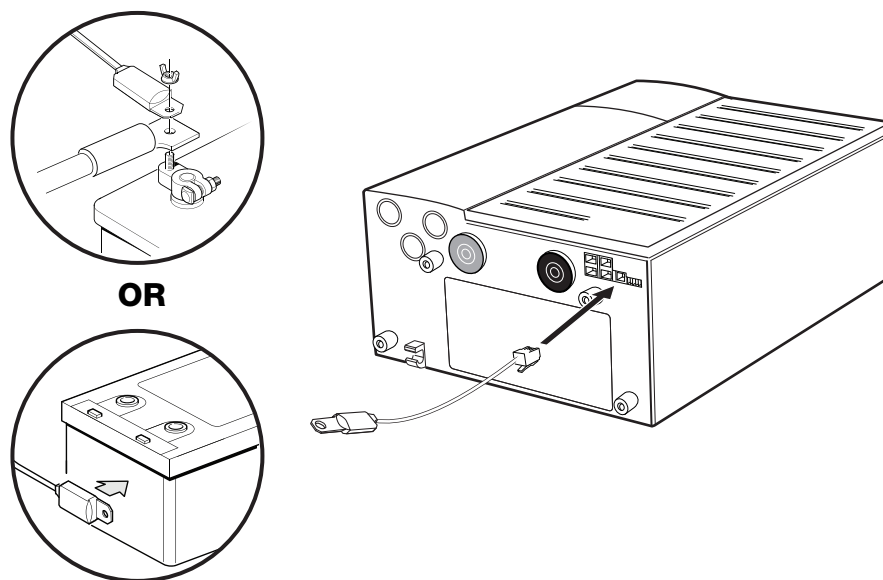

Figure 3-6 Battery Temperature Sensor Installation

Making DC Connections

Battery cables

⚠ DANGER

HAZARD OF ELECTRIC SHOCK, EXPLOSION, OR ARC FLASH

- Apply appropriate personal protective equipment (PPE) and follow safe electrical work practices. See NFPA 70E or CSA Z462.
- This equipment must only be installed and serviced by qualified electrical personnel.
- Never operate energized with covers removed
- Energized from multiple sources. Before removing covers identify all sources, de-energize, lock-out, and tag-out and wait 2 minutes for circuits to discharge
- Always use a properly rated voltage sensing device to confirm all circuits are de-energized.

Failure to follow these instructions will result in death or serious injury.

⚠ DANGER

HAZARD OF ELECTRIC SHOCK, EXPLOSION, OR ARC FLASH

- Remove watches, rings, or other metal objects.
- This equipment must only be installed and serviced by qualified electrical personnel.
- Keep sparks and flames away from the batteries.
- Use tools with insulated handles.
- Wear protective glasses, gloves and boots.
- Do not lay tools or other metal parts on top of batteries.

Failure to follow these instructions will result in death or serious injury.

⚠ DANGER

HAZARD OF ELECTRIC SHOCK, EXPLOSION, OR ARC FLASH

- Battery Circuit Breakers must be installed according to the specifications and requirements defined by Schneider Electric.
- Servicing of batteries must only be performed by qualified personnel knowledgeable of batteries and the required precautions. Keep unqualified personnel away from batteries.
- Disconnect the charging source prior to connecting or disconnecting battery terminals.

Failure to follow these instructions will result in death or serious injury.

⚠ WARNING

OVERHEATING OF DC TERMINALS AND CABLES

Overheating of the DC terminals or DC cables to dangerous temperatures may occur due to improper installation.

- Do not put anything between the cable lug and the terminal surface.
- Do not over-tighten connections; observe all recommended torque values.
- Do not apply any type of anti-oxidant paste until after the cable connection is tightened.
- Do not under size cables; install cables sized in accordance with national electrical code requirements.
- DC cables must have crimped copper compression lugs or crimped and soldered copper compression lugs; soldered connections alone are not acceptable. Lugs must be rated for use with fine-stranded cable.
- Do not use coarse-stranded cable; the lack of flexibility may pull DC terminal connections loose.

Failure to follow these instructions can result in death or serious injury.

NOTICE

DC REVERSE POLARITY

Before making the final DC connection or closing the DC breaker or disconnect, check cable polarity at both the battery and the inverter/charger. Positive (+) must be connected to positive (+). Negative (-) must be connected to negative (-).

Failure to follow these instructions can result in damage to equipment.

Battery cables are not included in the Conext XW+ Inverter/Charger package. Depending on your installation requirements, you will need to supply at least one pair of battery cables. For battery cable requirements, see “Battery Cable Requirements” on page 2–14.

Note: One pair of #4/0 AWG Arctic Ultraflex Blue™ battery cables is included with each Conext XW+ Power Distribution Panel and Conext XW+ Connection Kit for INV2 INV3 PDP. For more information, see “Optional Accessories” on page 1–5.

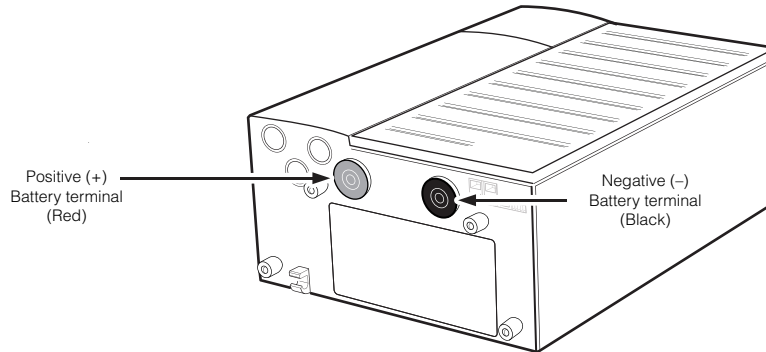

Figure 3-7 Battery terminals (bottom of Conext XW+)

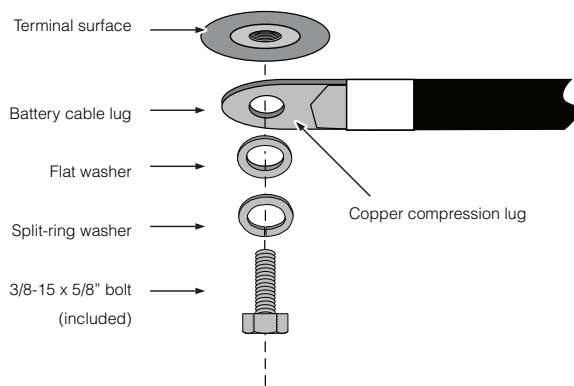

Figure 3-8 Battery cable connection

To connect the Conext XW+ Power Distribution Panel (PDP) to the Conext XW+ Inverter/Charger:

1. Connect the positive battery cable (pre-installed in the PDP) to the positive battery terminal at the bottom of the Conext XW+, as shown in Figure 3-9 on page 3-16.
2. Connect the negative battery cable (pre-installed in the PDP) to the negative battery terminal at the bottom of the Conext XW+ Inverter/Charger.

Note: When making the connections, be sure to observe correct hardware stacking and proper polarity, and ensure that nothing obstructs the connection between the terminal surface and the battery cable lug. (See Figure 3-8 on page 3-14.)

3. Attach the DC terminal covers (included with the Conext XW+ Inverter/Charger) to the bottom of the Conext XW+ DC terminals.

To connect the Conext XW+ Power Distribution Panel (PDP) to the Battery Bank:

1. Connect your battery cables (not included) to the PDP. Connect the negative battery cable to the DC Negative Bus, and the positive battery cable to the input end of the GJ250A 160 VDC, 3/8" stud DC breaker (pre-installed in the PDP), as shown in Figure 3-9 on page 3-16.

Note: To properly attach and torque the positive cable to the DC breaker, you may need to temporarily remove the breaker from the rail.



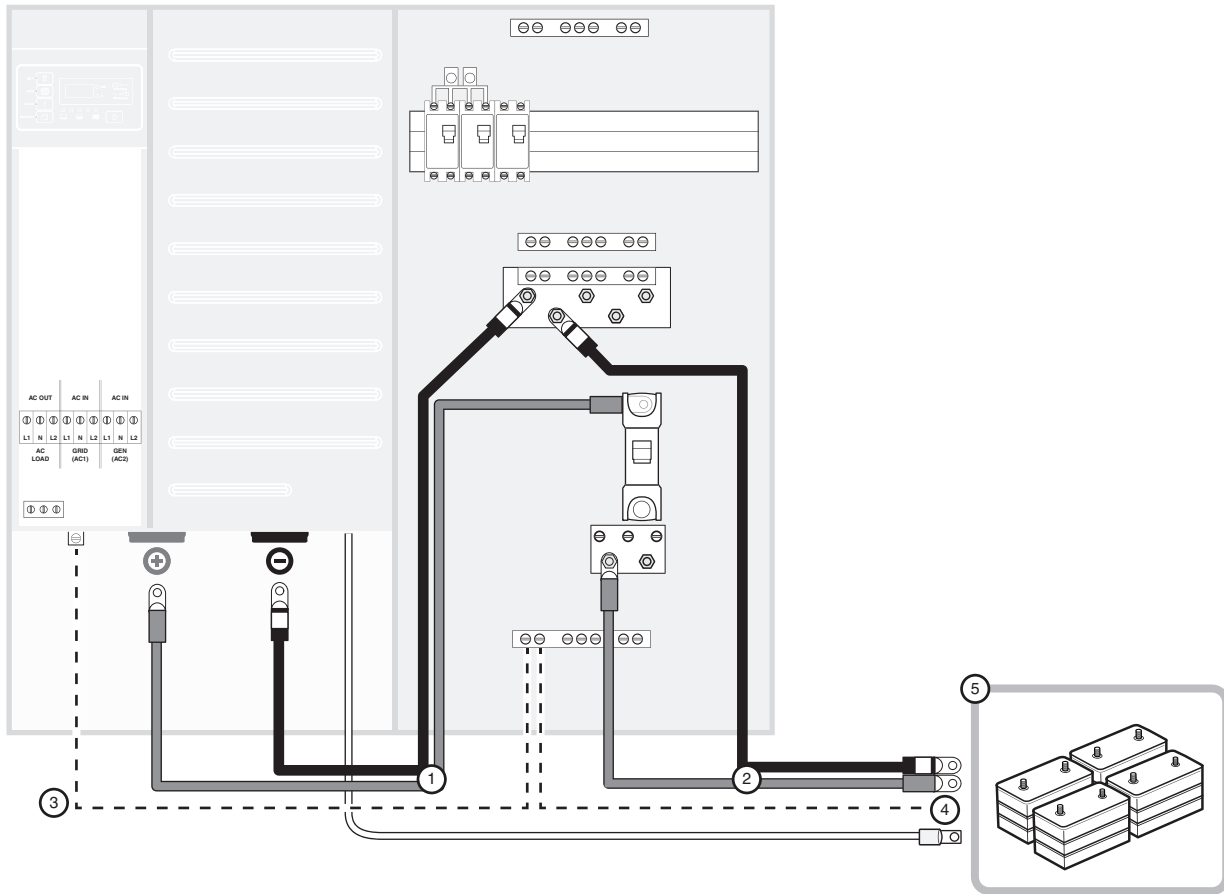

2. Route your battery cables from the PDP, through your preferred conduit path, to the battery location. Do not connect the cables to the battery yet.

Note: Before connecting the DC cables from the PDP to the battery, perform the procedures in "Making AC Connections" on page 3-17.



LEGEND

- 1. #4/0 AWG Arctic Ultraflex Blue battery cables (included with PDP)
- 2. Battery cables (not included)
- 3. Battery system bonding wire
- 4. Grounding conductor
- 5. Vented battery enclosure

-  Positive (+) Battery cable
-  Negative (-) Battery cable
-  BTS cable
-  Grounding wire

Actual wiring requirements may vary.
 Cable routing may vary. See Knockout Selection on page 2-5 and Communications Network Preparation on page 2-12.
 For torque values, see page 2-16 and 2-17.

Figure 3-9 DC Connections to a Single Inverter Using a PDP

Making AC Connections

This section provides instructions for making AC connections between the Conext XW+ Inverter/Charger and the Conext XW+ Power Distribution Panel (using the pre-installed AC cables in the PDP) and between the PDP and your inverter load sub-panel.

Note: Install an inverter load sub-panel and AC conduit before completing your Conext XW+ installation. For more information, see “AC Wiring to the Inverter Load Sub-Panel” on page 3–26.

Note: Do not use a GFCI equipped AC source to power either the Grid (AC1) or Generator (AC2) inputs. The AC input filters on the Conext XW+ may cause nuisance tripping of ground fault protected outputs.

NOTICE
<p>BACK FED AC POWER</p> <p>Back fed AC Power can damage equipment. Do not wire the inverter's AC output port directly to the utility line or generator output.</p> <p>Failure to follow these instructions can result in damage to equipment.</p>

Note: Wiring the inverter's AC output to the utility or generator output will cause severe damage to the inverter which is not covered under warranty.

AC Terminal Block

⚠ DANGER

HAZARD OF ELECTRIC SHOCK, EXPLOSION, OR ARC FLASH

- Apply appropriate personal protective equipment (PPE) and follow safe electrical work practices. See NFPA 70E or CSA Z462.
- This equipment must only be installed and serviced by qualified electrical personnel.
- Never operate energized with covers removed
- Energized from multiple sources. Before removing covers identify all sources, de-energize, lock-out, and tag-out and wait 2 minutes for circuits to discharge
- Always use a properly rated voltage sensing device to confirm all circuits are de-energized.

Failure to follow these instructions will result in death or serious injury.

⚠ DANGER

HAZARD OF ELECTRIC SHOCK, EXPLOSION, OR ARC FLASH

- Remove watches, rings, or other metal objects.
- This equipment must only be installed and serviced by qualified electrical personnel.
- Keep sparks and flames away from the batteries.
- Use tools with insulated handles.
- Wear protective glasses, gloves and boots.
- Do not lay tools or other metal parts on top of batteries.

Failure to follow these instructions will result in death or serious injury.

⚠ DANGER**HAZARD OF ELECTRIC SHOCK, EXPLOSION, OR ARC FLASH**

- Battery Circuit Breakers must be installed according to the specifications and requirements defined by Schneider Electric.
- Servicing of batteries must only be performed by qualified personnel knowledgeable of batteries and the required precautions. Keep unqualified personnel away from batteries.
- Disconnect the charging source prior to connecting or disconnecting battery terminals.

Failure to follow these instructions will result in death or serious injury.

To access the AC terminal block, you will need to remove the AC access panel. For more information, see “Removing the AC Access Panel and PDP Internal Faceplates” on page 3–2.

The AC terminal block includes three terminals each (L1, L2, and Neutral) for AC Grid input (AC1), AC Generator input (AC2), and AC Out (AC LOAD) connections. (see Figure 3-10 on page 3–19.)

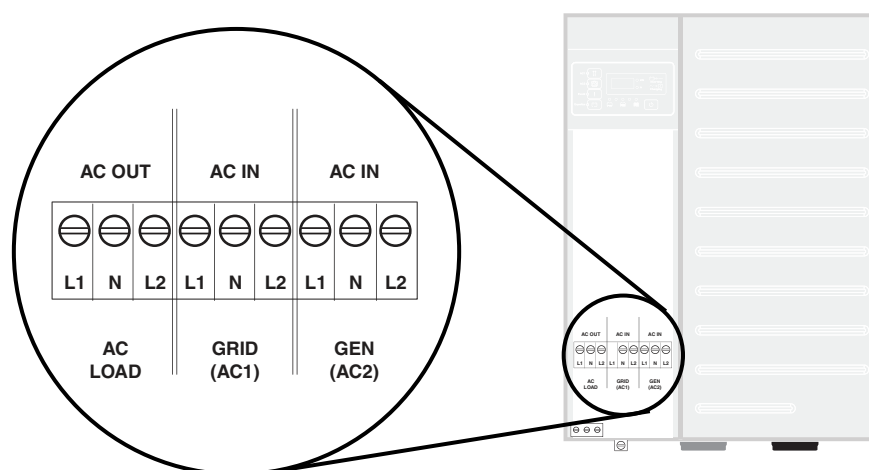
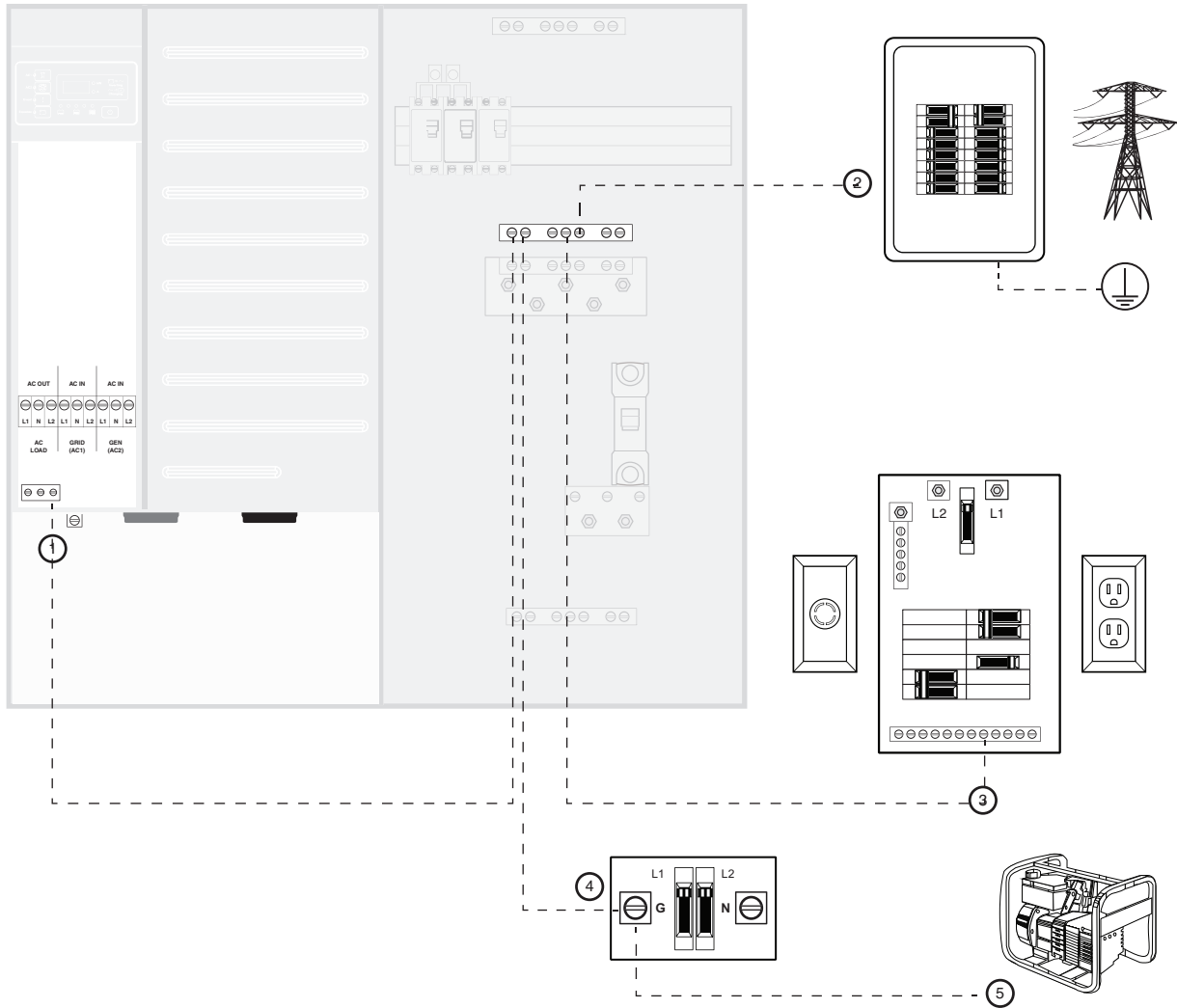

Figure 3-10 AC terminal block

The neutral inputs are connected to each other, requiring only one neutral connection when installed with a Conext XW+ Power Distribution Panel. Without the PDP, additional neutral connections may be required at the input sources.

AC Equipment Grounding

See Table 2-4 on page 2-16 for torque values for the AC terminal and AC ground bar. See Table 2-8 on page 2-16 for torque requirements for the ground bar in the Conext XW+ Power Distribution Panel.



LEGEND

- 1. To AC ground bar
- 2. To main utility panel
- 3. To inverter load sub-panel

Note: May not be required if DC ground is used instead.

- 4. Generator disconnect

Note: Depending on the location of the generator and local code requirements, the generator disconnect may be located in the power distribution panel.

- 5. To AC generator

Grounding requirements may vary.

Cable routing may vary. See Knockout Selection on page 2-5 and Communications Network Preparation on page 2-12. For torque values, see page 2-16 and 2-17.

Figure 3-11 AC Equipment Grounding With the PDP

AC System Bonding

⚠ WARNING

MULTIPLE AC NEUTRAL-TO-GROUND BONDS

Verify that only one neutral-to-ground bond exists in the system. Having more than one neutral-to-ground bond in a system violates local electrical codes, may create a shock or fire hazard, and may cause some sensitive equipment to malfunction.

Failure to follow these instructions can result in death or serious injury.

System bonding refers to connection (bonding) of one of the current-carrying conductors of an electrical system to ground. This creates a "grounded conductor" or "neutral" that is at ground potential, but is separate from the equipment ground conductor. System bonding must be done at only one location. Procedures for system bonding vary between on-grid and off-grid systems.

System bonding for on-grid systems

The Conext XW+ does not connect the neutral to ground. The AC input neutral is already bonded to ground by the incoming utility grid system. Do not connect the neutral to ground in any additional location.

The Conext XW+ does not switch or disconnect the AC neutral in any mode of operation, so even in invert (back-up) mode, the inverter load sub-panel neutral is bonded to ground by the utility grid system. It must not be grounded again in the inverter load sub-panel.

System bonding for off-grid systems

In a system without a generator, or with a generator that does not provide a grounded neutral, you must make the connection from neutral to ground in the inverter load sub-panel or main distribution panel, as applicable.

In a system with a generator that provides a grounded neutral, no additional connection from neutral to ground is needed. Do not connect neutral to ground in the inverter load sub-panel or main distribution panel, as applicable.

AC wiring the Conext XW+ Power Distribution Panel to the Conext XW+ Inverter/Charger

To connect the Conext XW+ Power Distribution Panel to the Conext XW+ Inverter/Charger:

1. In the Conext XW+ Power Distribution Panel (PDP), locate the wire labelled **INV1 N-LOAD (SPLIT PHASE)**, pre-installed in the neutral bus bar N-LOAD terminal. Connect the **INV1 N-LOAD (SPLIT PHASE)** wire to the AC Load terminal (**N-LOAD**) on the Conext XW+ Inverter/Charger, as shown in Figure 3-12 on page 3-23.
2. Locate the wires labelled **INV1 L1-LOAD** and **INV1 L2-LOAD**, pre-installed in the terminals at the input (top) side of the 60 A, 120/240 VAC, two-pole, type QOU output AC breaker in the PDP. Connect the **INV1 L1-LOAD** and **INV1 L2-LOAD** wires to the AC Load terminals (**L1 -LOAD** and **L2-LOAD**, respectively) on the Conext XW+ Inverter/Charger.
3. Locate the wires labelled **INV1 L1-GRID** and **INV1 L2-GRID**, pre-installed in the terminals at the bottom of the output breaker in the PDP.
4. Connect the **INV1 L1-GRID** and **INV1 L2-GRID** to the Conext XW+ Inverter/Charger, using one of the following methods (depending on your installation):
 - If the AC source will be the utility grid, connect to the **GRID (AC1)** terminals (**L1-GRID**, **L2-GRID**) on the Conext XW+ Inverter/Charger. (See Figure 3-12 on page 3-23.)

Note: In an on-grid system with a generator, you will need to install an additional 60 A, 120/240 VAC, two-pole, type QOU AC breaker onto the DIN rail. For information, see Figure 3-13 on page 3-24.

- If the system will be off-grid and the only AC source will be a generator, connect these wires to the **GEN (AC2)** terminals (**L1-GEN**, **L2-GEN**) on the Conext XW+ Inverter/Charger. (See Figure 3-14 on page 3-25.)

Note: Both lines (L1 and L2) of input power must be connected in order for the Conext XW+ Inverter/Charger to operate. For example, L1 and L2 of Grid Input L1 and L2 of Gen Input need to be connected.

Note: Additional neutral terminals (N-GRID, N-GEN) are provided on the Conext XW+ Inverter/Charger for installations that do not use the XW+ Power Distribution Panel. For more information, see “Wiring the Conext XW+ Inverter/Charger without a PDP” on page 3-67.

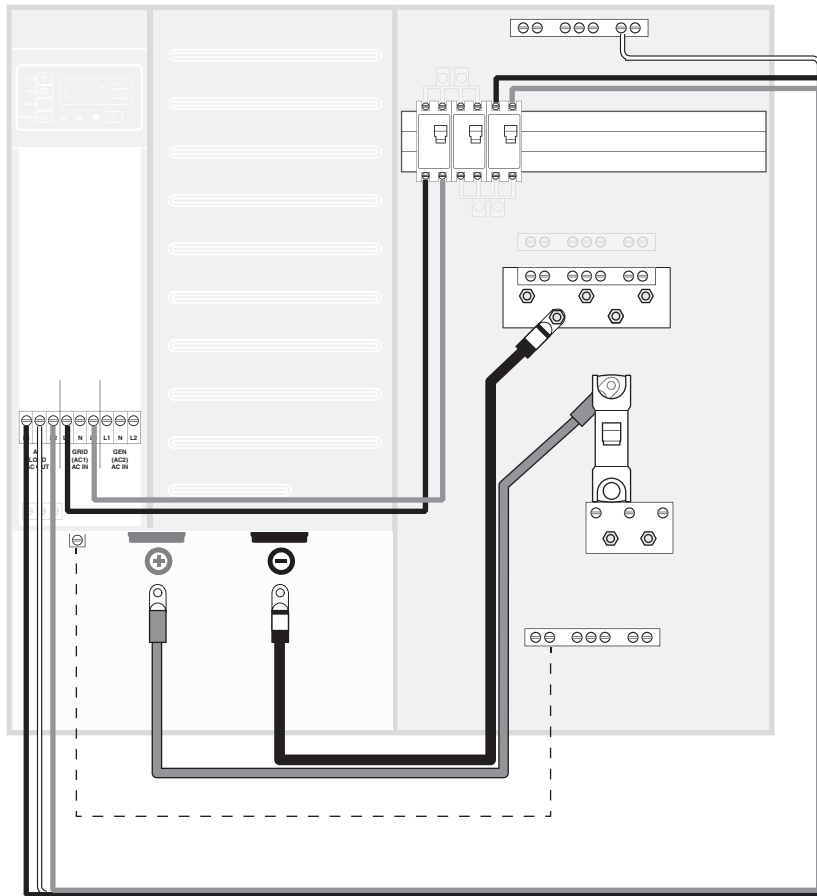

LEGEND

- Grounding wire
- ==== Neutral
- Hot L1
Hot L2
- Positive (+)
Battery cable
- Negative (-)
Battery cable

Actual wiring requirements may vary.
Cable routing may vary. See Knockout Selection on page 2-5 and Communications Network Preparation on page 2-12.
For torque values, see page 2-16 and 2-17.

Figure 3-12 Wiring the Conext XW+ Power Distribution Panel to the Conext XW+ Inverter/Charger

Wiring the Conext XW+ Power Distribution Panel to a Generator (On-Grid)

In an on-grid installation, the generator will require an additional 60 A, 120/240 VAC, two-pole, type QOU AC breaker to be installed in the Conext XW+ Power Distribution Panel.

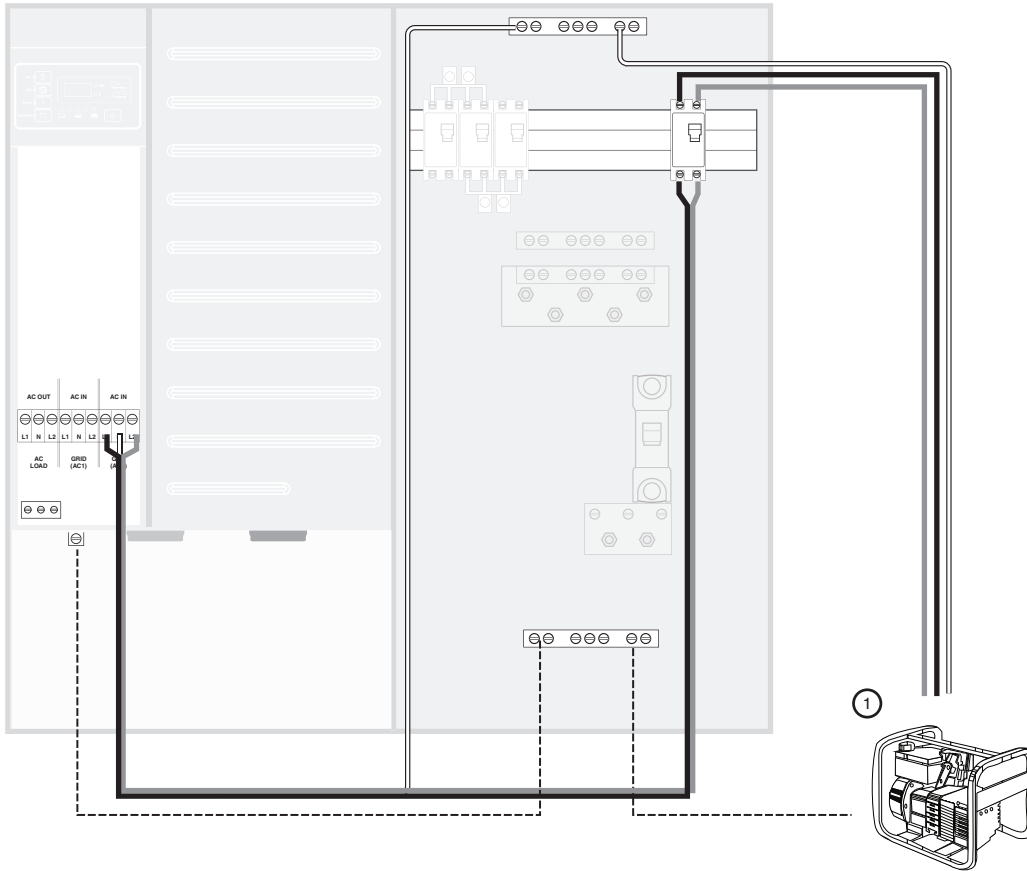

LEGEND

- 1. AC generator
- Grounding wire
- ==== Neutral
- Hot L1
—— Hot L2

Cable routing may vary. See Knockout Selection on page 2-5 and Communications Network Preparation on page 2-12. For torque values, see page 2-16 and 2-17.

Figure 3-13 Wiring the Conext XW+ Power Distribution Panel to a Generator (On-Grid)

Wiring the Conext XW+ Power Distribution Panel to a Generator (Off-Grid)

In an off-grid installation, the generator can be connected to the breakers provided in the PDP. No additional breaker is required.

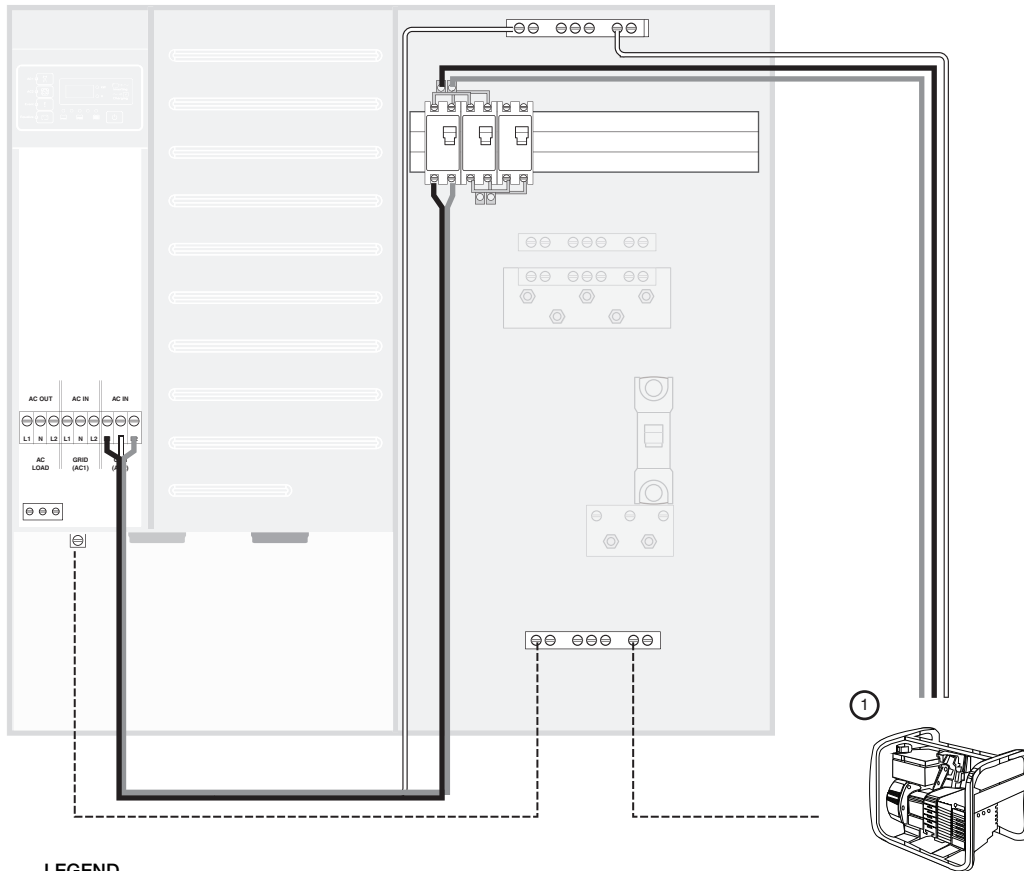

LEGEND

- 1. AC generator
- Grounding wire
- ==== Neutral
- Hot L1
- Hot L2

Actual wiring requirements may vary.
 Cable routing may vary. See Knockout Selection on page 2-5 and Communications Network Preparation on page 2-12.
 For torque values, see page 2-16 and 2-17.

Figure 3-14 Wiring the PDP to a Generator (Off Grid)

AC Wiring to the Inverter Load Sub-Panel

⚠ DANGER

HAZARD OF ELECTRIC SHOCK, EXPLOSION, OR ARC FLASH

- Apply appropriate personal protective equipment (PPE) and follow safe electrical work practices. See NFPA 70E or CSA Z462.
- This equipment must only be installed and serviced by qualified electrical personnel.
- Never operate energized with covers removed
- Energized from multiple sources. Before removing covers identify all sources, de-energize, lock-out, and tag-out and wait 2 minutes for circuits to discharge
- Always use a properly rated voltage sensing device to confirm all circuits are de-energized.

Failure to follow these instructions will result in death or serious injury.

⚠ DANGER

HAZARD OF ELECTRIC SHOCK, EXPLOSION, OR ARC FLASH

- Remove watches, rings, or other metal objects.
- This equipment must only be installed and serviced by qualified electrical personnel.
- Keep sparks and flames away from the batteries.
- Use tools with insulated handles.
- Wear protective glasses, gloves and boots.
- Do not lay tools or other metal parts on top of batteries.

Failure to follow these instructions will result in death or serious injury.

▲ DANGER**HAZARD OF ELECTRIC SHOCK, EXPLOSION, OR ARC FLASH**

- Battery Circuit Breakers must be installed according to the specifications and requirements defined by Schneider Electric.
- Servicing of batteries must only be performed by qualified personnel knowledgeable of batteries and the required precautions. Keep unqualified personnel away from batteries.
- Disconnect the charging source prior to connecting or disconnecting battery terminals.

Failure to follow these instructions will result in death or serious injury.

An inverter load sub-panel and AC conduit must be installed before your Conext XW+ installation can be completed.

Wiring

Wiring for connections between the PDP and the inverter load sub-panel is not included. Power distribution jumpers in the PDP accept up to a #2/0 AWG (9.27mm) cable (maximum).

See “Torque Values” on page 2–16 for torque requirements

To install the inverter load sub-panel and AC conduit:

1. Choose a location for the inverter load sub-panel and install it according to the manufacturer's directions.
2. Install an AC conduit between the PDP and the inverter load sub-panel.
3. Determine which circuits the Conext XW+ Inverter/Charger will power and install the appropriate circuit breakers into the inverter load sub-panel.
4. For on-grid systems:
 - a) Disconnect all power to the main AC panel (utility grid).
 - b) Choose which circuits will be backed by the inverter(s), and remove their wires from the main panel.
 - c) Reroute these wires to the new inverter load sub-panel.
5. Remove unused breakers from utility panel.
6. Install a 60 amp maximum (disconnect) main circuit breaker in the inverter load sub-panel.

NOTICE**BACK FED AC POWER**

Back fed AC Power can damage equipment. Do not wire the inverter's AC output port directly to the utility line or generator output.

Failure to follow these instructions can result in damage to equipment.

To connect the Conext XW+ Power Distribution Panel to the Inverter Load Sub-Panel and Utility Grid:

1. Connect L1 (from the L1 output jumper) and L2 (from the L2 output jumper), Neutral, and Ground to your inverter load sub-panel.
2. Connect the ground wire between the PDP and the main AC Panel (utility grid).
3. Connect Neutral from the PDP to the main AC panel (utility grid).
4. Connect L1 and L2 from the input side of the 60 A, 120/240 VAC, two-pole, Type QOU AC1 breaker (L1 and L2 jumpers) to the main AC panel (utility grid).

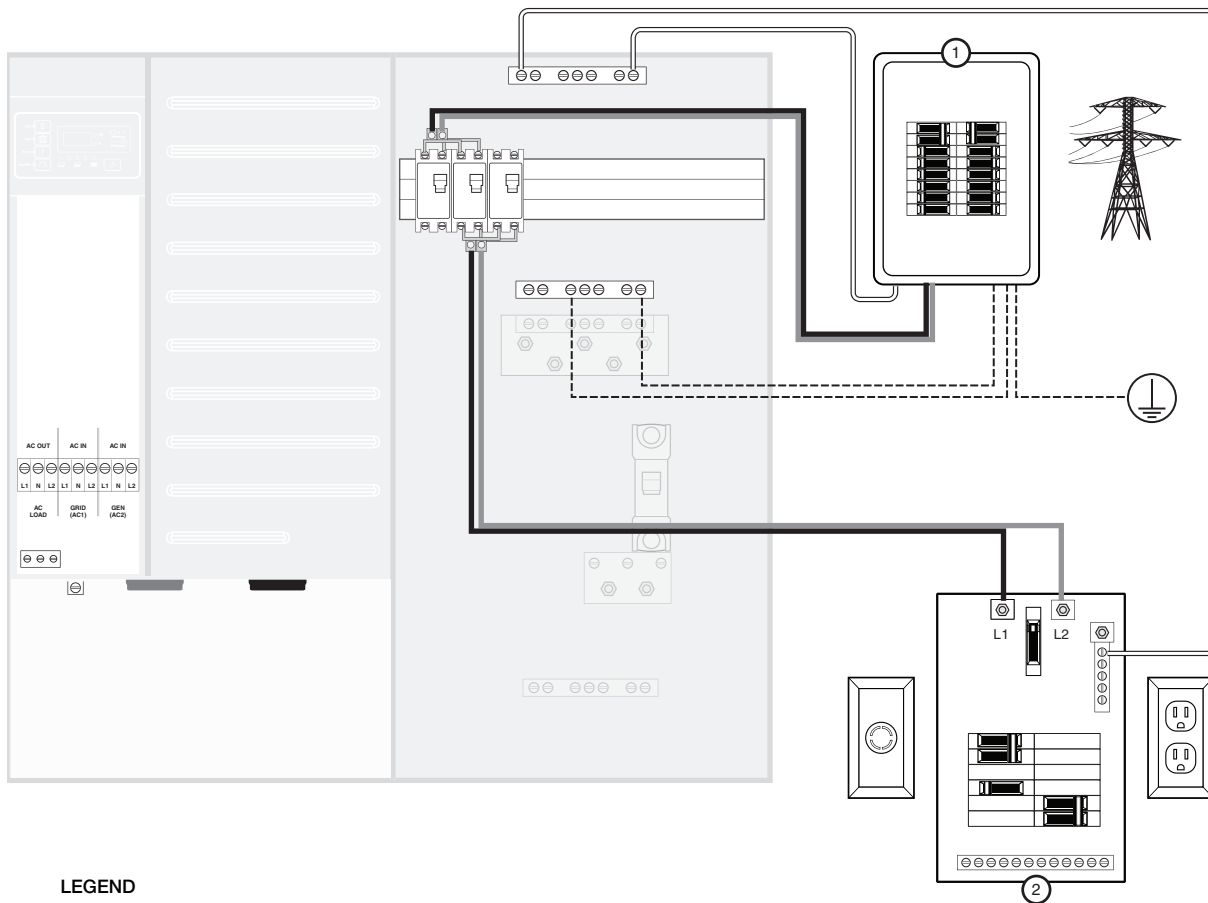

LEGEND

- 1. Main utility panel
- 2. Inverter load sub-panel
- Grounding wire
- ===== Neutral
- ===== Hot L1
- ===== Hot L2

Actual wiring requirements may vary.
 Cable routing may vary. See Knockout Selection on page 2-5 and Communications Network Preparation on page 2-12.
 For torque values, see page 2-16 and 2-17.

Figure 3-15 Wiring the PDP to the Inverter Load Sub-Panel or Utility Grid

Basic Functional Test – Single Inverter

Complete the following steps to perform a basic functional test of the Conext XW+ Inverter/Charger. If any test fails, refer to the Troubleshooting section in the *Conext XW+ Inverter/Charger Owner's Guide* for assistance.

Confirming All Connections

After the AC and DC wiring have been installed and connected, check that all connections are correct and secure, and re-secure the AC access panel.

⚠ DANGER

HAZARD OF ELECTRIC SHOCK, EXPLOSION, OR ARC FLASH

- Apply appropriate personal protective equipment (PPE) and follow safe electrical work practices. See NFPA 70E or CSA Z462.
- This equipment must only be installed and serviced by qualified electrical personnel.
- Never operate energized with covers removed
- Energized from multiple sources. Before removing covers identify all sources, de-energize, lock-out, and tag-out and wait 2 minutes for circuits to discharge
- Always use a properly rated voltage sensing device to confirm all circuits are de-energized.

Failure to follow these instructions will result in death or serious injury.

⚠ DANGER

HAZARD OF ELECTRIC SHOCK, EXPLOSION, OR ARC FLASH

- Remove watches, rings, or other metal objects.
- This equipment must only be installed and serviced by qualified electrical personnel.
- Keep sparks and flames away from the batteries.
- Use tools with insulated handles.
- Wear protective glasses, gloves and boots.
- Do not lay tools or other metal parts on top of batteries.

Failure to follow these instructions will result in death or serious injury.

⚠ DANGER

HAZARD OF ELECTRIC SHOCK, EXPLOSION, OR ARC FLASH

- Battery Circuit Breakers must be installed according to the specifications and requirements defined by Schneider Electric.
- Servicing of batteries must only be performed by qualified personnel knowledgeable of batteries and the required precautions. Keep unqualified personnel away from batteries.
- Disconnect the charging source prior to connecting or disconnecting battery terminals.

Failure to follow these instructions will result in death or serious injury.

Applying DC Power to the Inverter

NOTICE

DC REVERSE POLARITY

Before making the final DC connection or closing the DC breaker or disconnect, check cable polarity at both the battery and the inverter/charger. Positive (+) must be connected to positive (+). Negative (-) must be connected to negative (-).

Failure to follow these instructions can result in damage to equipment.

To apply DC power to the inverter:

1. Before applying DC power to the inverter, measure the voltage and check polarity at all connections. (Measure at the battery side of the disconnect or breaker.)

Note: Voltage should be between 40 to 64 volts for a 48-volt system. If the DC voltage is low, the battery bank must be charged externally. Charge the battery bank, and then restart the functional test.

If the DC voltage is lower than the Low Battery Cut Out (LBCO) setting (46 volts for a 48-volt system) a DC Under Voltage Fault (F48) will be triggered. If the DC voltage is lower than the default LBCO voltage, lower the LBCO setting accordingly.

2. Apply battery (DC) power to the inverter by closing the battery bank DC disconnect.
The inverter will power up in standby mode, and the inverter information panel will display **5**Ⓢ**** (standby), as shown in Figure 3-16.

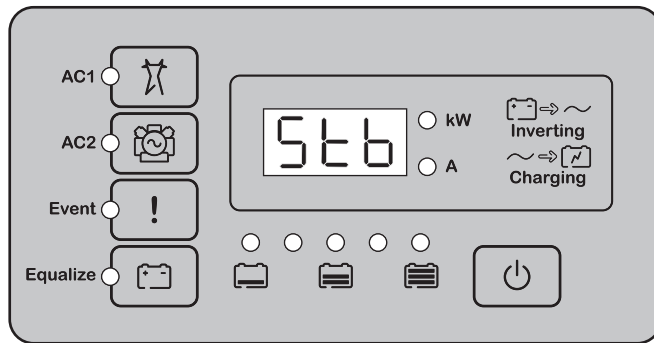

Figure 3-16 Power-up display

Enabling the Inverter

Invert mode is enabled by default, and the Conext XW+ should begin inverting upon transitioning from standby mode. If invert mode is disabled, the inverter information panel will display "---" once out of standby mode, as shown in Figure 3-17. If the Conext XW+ powers up in standby mode, press the STARTUP/SHUTDOWN button momentarily to change the mode from standby to operating.

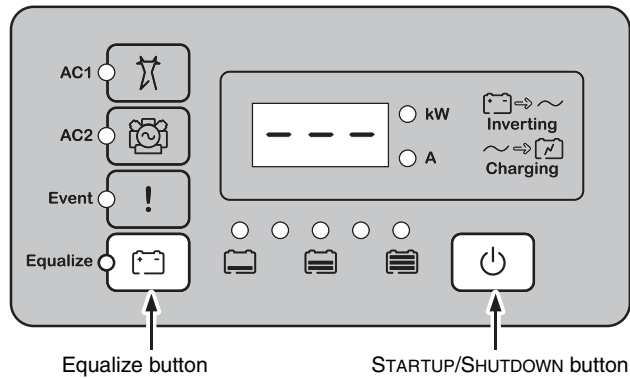

Figure 3-17 Disabled mode

To enable the inverter:

- ◆ On the inverter information panel, simultaneously press the STARTUP/ SHUTDOWN button and the Equalize button. The Conext XW+ is now enabled, and E_n (enabled) is briefly displayed on the inverter information panel, as shown in Figure 3-18.

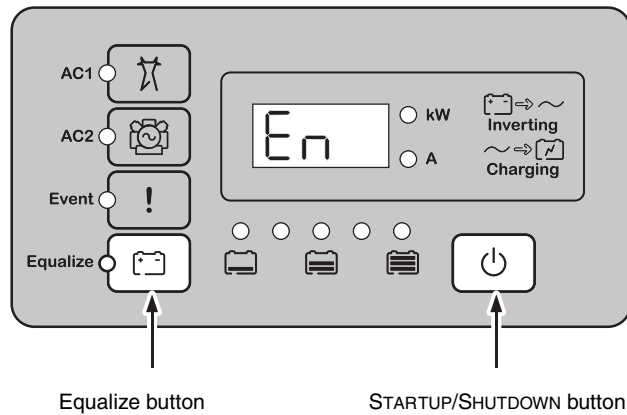
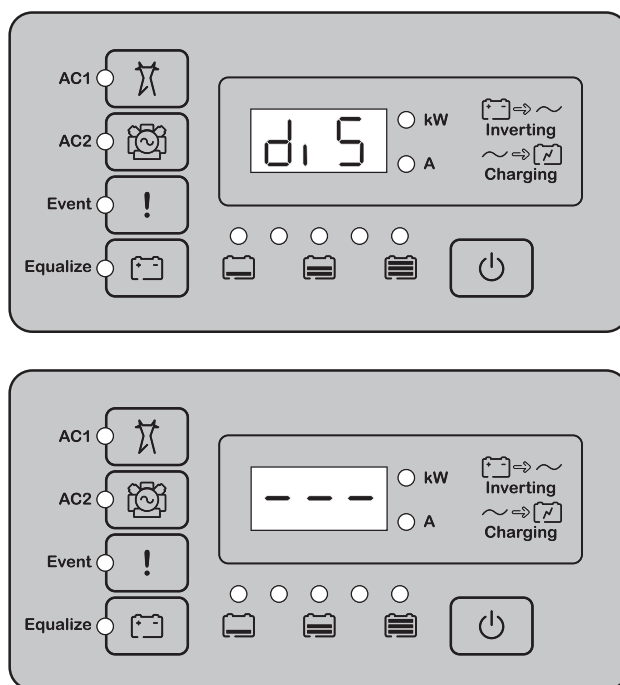

Figure 3-18 Enabled mode

To disable the inverter:

- ◆ On the inverter information panel, simultaneously press the STARTUP/ SHUTDOWN button and the Equalize button. The Conext XW+ is now disabled, and *d,5* (disabled) is briefly displayed on the inverter information panel, followed by "---" (as shown in Figure 3-19).

**Figure 3-19** Transition to disabled mode

3. Monitor the invert (green kW) LED to confirm which mode the inverter is in:
 - *kW LED OFF* – Invert mode is disabled. The inverter/charger is not powering the AC loads. However, if good AC is present, it is passed through to the loads.
 - *5ch* displayed on the inverter information panel – The inverter/charger is in *search* mode and is looking for an AC load greater than the *Search Watts* setting (default = 25 watts). The display shows *5ch* (Search) when this mode has been enabled.
 - *LED ON* – The inverter/charger is on. The inverter is operating and is able to provide power to the AC loads. This is the default mode on initial power-up once the unit is taken out of standby mode.

If the inverter is not operating or the inverter LED (kW) does not turn on, check all connections. Check the inverter's DC voltage and polarity on the positive (+) and negative (-) terminals. Check the Fault LED. If the fault LED is on, check for a fault

code on the information panel. Correct the reported fault and clear the fault by acknowledging it. If the DC voltage is low, then the battery bank needs to be charged externally. Charge the battery bank and restart the functional test.

AC Voltage Check

Note: This test requires the use of a voltmeter.

To perform an AC voltage check:

1. With the inverter on (green kW LED is on and steady), verify the AC voltage at AC Loads block terminal L1-Load to N-Load.
2. Verify that neutral is bonded to ground in the system by measuring the hot and neutral voltages relative to ground. Neutral-to-ground should equal zero (0) volts.
3. After confirming the correct AC voltage, turn on your AC output breaker and place a load on the inverter (plug in a light or other load to an outlet the inverter is powering).
4. Confirm that the AC load that was just turned on is working properly.

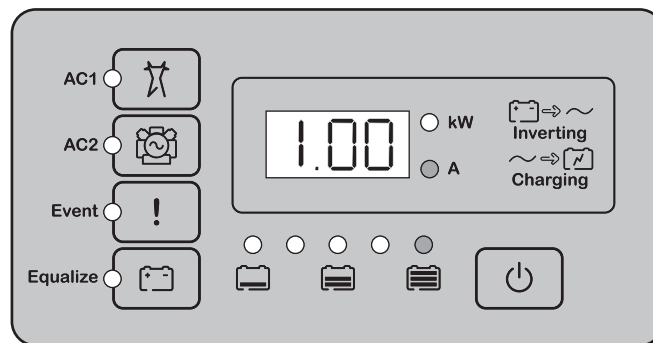

Figure 3-20 Checking AC Voltage

Confirming Battery Charger Operation

To confirm battery charger operation:

1. Apply AC from grid or generator. LEDs will blink while the power source is qualified.
2. Check LEDs (AC1 or AC2) on the front panel. One of them must be ON for the unit to charge.
3. Check the amp (A) LED. If the A LED is ON, the unit is charging and the battery current is displayed on the inverter information panel.

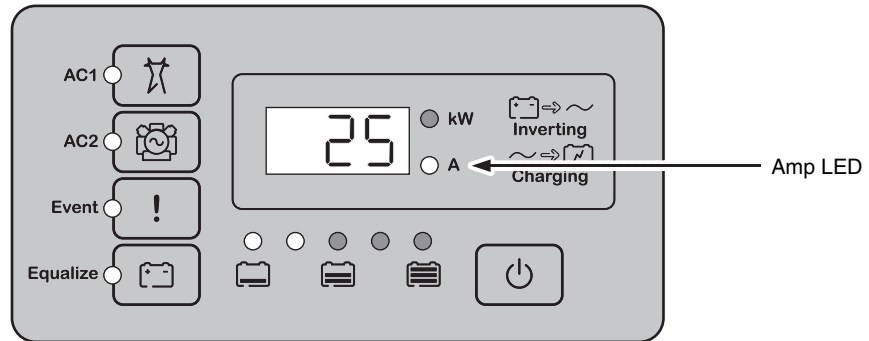

Figure 3-21 Checking Charging Operation

Note: Unless the inverter/charger settings have been changed, the inverter will charge as if it has a large (> 440 Ah) flooded battery bank (factory default setting). In newly installed systems, adjust the battery charging set points to match the batteries as installed.

This completes the functional test. If any of the internal set points need to be adjusted on the Conext XW+, consult the configuration chapter of the *Conext XW+ Inverter/Charger Owner's Guide*.

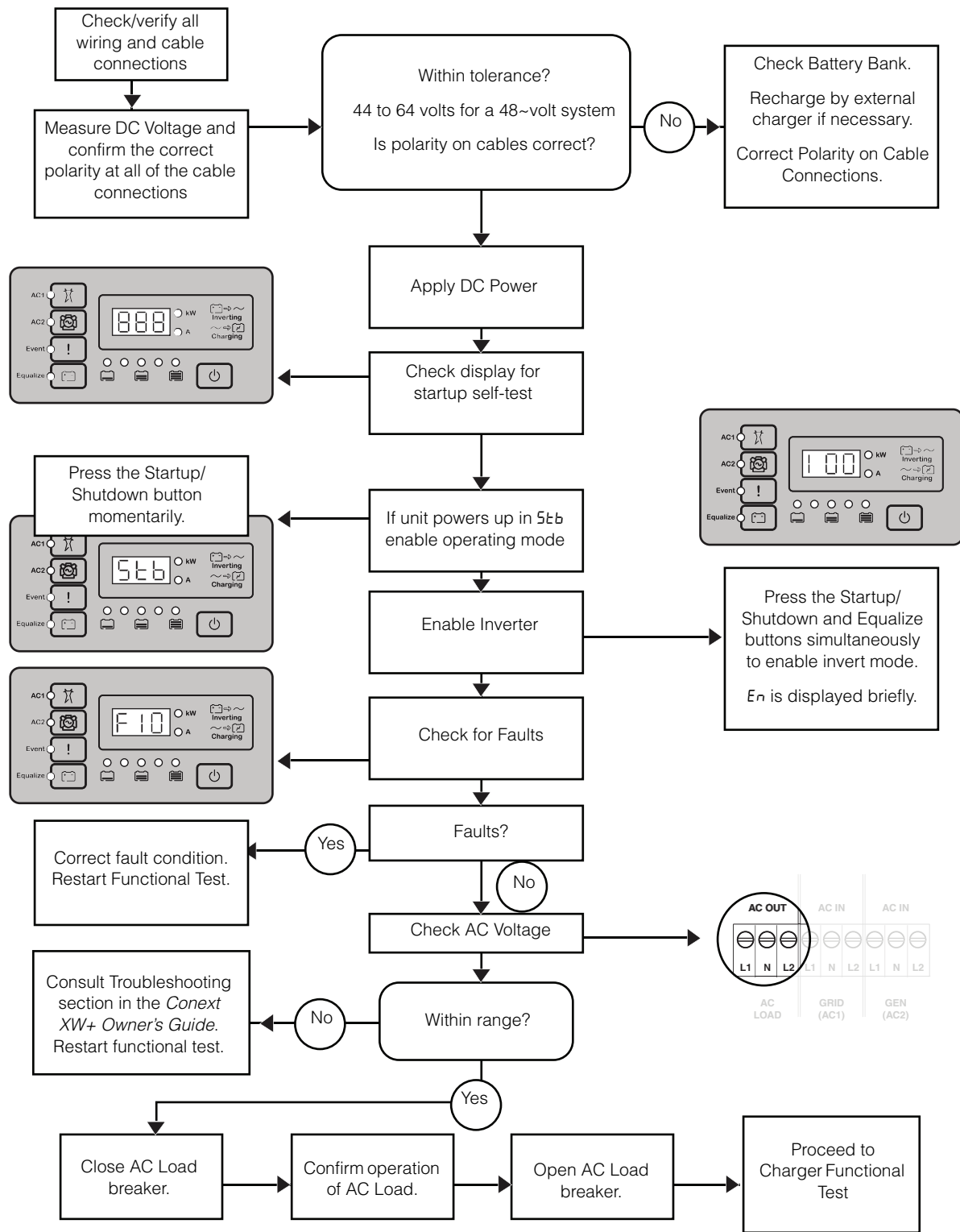

Figure 3-22 Functional Test for Single Inverter Systems

Wiring Additional Conext XW+ units with a PDP

This section provides instructions for making AC and DC connections between multiple Conext XW+ units and a Conext XW+ Power Distribution Panel, using the cables that are included with each PDP and Conext XW+ Connection Kit for INV2 INV3 PDP.

To install a balanced three-phase system, see “Wiring a Balanced Three-Phase System” on page 3–56.

Note: The installation steps described in this section require a Conext XW+ Connection Kit for INV2 INV3 PDP (part number 865-1020-01) and Conext 120/240VAC Breaker Kit (part number 865-1215-01) for each additional Conext XW+ Inverter/Charger.

For more information, contact your local Schneider Electric Sales Representative or visit our website at: <http://www.schneider-electric.com/sites/corporate/en/support/operations/local-operations/local-operations.page>

Pre-Installation Steps

⚠ DANGER

HAZARD OF ELECTRIC SHOCK, EXPLOSION, OR ARC FLASH

- Apply appropriate personal protective equipment (PPE) and follow safe electrical work practices. See NFPA 70E or CSA Z462.
- This equipment must only be installed and serviced by qualified electrical personnel.
- Never operate energized with covers removed
- Energized from multiple sources. Before removing covers identify all sources, de-energize, lock-out, and tag-out and wait 2 minutes for circuits to discharge
- Always use a properly rated voltage sensing device to confirm all circuits are de-energized.

Failure to follow these instructions will result in death or serious injury.

⚠ DANGER

HAZARD OF ELECTRIC SHOCK, EXPLOSION, OR ARC FLASH

- Remove watches, rings, or other metal objects.
- This equipment must only be installed and serviced by qualified electrical personnel.
- Keep sparks and flames away from the batteries.
- Use tools with insulated handles.
- Wear protective glasses, gloves and boots.
- Do not lay tools or other metal parts on top of batteries.

Failure to follow these instructions will result in death or serious injury.

▲ DANGER

HAZARD OF ELECTRIC SHOCK, EXPLOSION, OR ARC FLASH

- Battery Circuit Breakers must be installed according to the specifications and requirements defined by Schneider Electric.
- Servicing of batteries must only be performed by qualified personnel knowledgeable of batteries and the required precautions. Keep unqualified personnel away from batteries.
- Disconnect the charging source prior to connecting or disconnecting battery terminals.

Failure to follow these instructions will result in death or serious injury.

Before installing additional Conext XW+ units, disconnect all power from the system.

Depending on your installation, you may need to perform the following pre-installation steps:

1. Wall-mount additional Conext XW+ Inverter/Charger(s), as needed. See “Wall-Mounting the Conext XW+ and PDP” on page 2–9.
2. Install Conext XW+ Conduit Box as needed. See “Installing the Conext XW+ Conduit Box” on page 2–10.
3. Prepare the communications network. See “Communications Network Preparation” on page 2–12.
4. Install a Conext System Control Panel or Conext ComBox to configure programmable settings and to name specific network components, as needed. See “Conext XW+ Inverter/Charger Accessories Installation” on page 5–1.

Note: When installing more than one Conext XW+ Inverter/Charger at a location, use a Conext System Control Panel, Conext ComBox, or Conext Configuration Tool to give a unique name to each Conext XW+ (and other Xanbus-enabled devices), and to modify the factory-installed default settings to match and support the installed configuration.

Up to three Conext XW+ units can be connected to a PDP in a split-phase system. To connect two Conext XW+ units to a PDP, see “Dual Inverter/Charger Installation” on page 3–40. To connect three Conext XW+ Inverter/Chargers to a PDP, see “Triple Inverter/Charger Installation” on page 3–46.

Conext XW+ Inverter/Charger Grounding

⚠ WARNING

UNGROUNDING EQUIPMENT

Equipment ground terminals must be reliably connected to ground by appropriately sized grounding conductors. All installations must comply with national and local codes. Consult local and national codes for specific grounding and bonding requirements.

Failure to follow these instructions can result in death or serious injury.

The Conext XW+ is provided with ground terminals that must be reliably connected to ground (protective earth) by appropriately sized equipment grounding conductors. System grounding for the AC and DC systems must be done according to all applicable NEC and local installation codes.

For more information about system grounding, see “Grounding the DC System” on page 3–8 and “AC Equipment Grounding” on page 3–20.

Dual Inverter/Charger Installation

This section provides instructions for adding a second Conext XW+ to your installation. Complete the following installation steps only after you have already connected the PDP to the first Conext XW+, as shown in “Wiring the Conext XW+ Inverter/Charger with a PDP” on page 3–7.

DC Grounding

See “Grounding the DC System” on page 3–8.

DC positive bus bar installation

1. Remove the existing bus bar from the bottom terminal of the GJ250A 160 VDC, 3/8" DC disconnect/breaker (pre-installed in the PDP).
2. Install a second GJ250A - DC rated breaker (included with the Conext XW+ Connection Kit for INV2 INV3 PDP) next to the existing DC disconnect/breaker.
3. Install the DC positive bus bar included with the Conext XW+ Connection Kit for INV2 INV3 PDP. (This DC positive bus bar supports up to three GJ250A - DC rated breakers.)
4. Remove the appropriate knockout from the Conext XW+ Power Distribution Panel lower faceplate.

Note: Replace faceplates after all AC and DC wiring is complete.

DC Wiring for a Dual-Inverter System

1. Using the instructions provided in “Making DC Connections” on page 3–11, make DC connections from the Conext XW+ Power Distribution Panel to:
 - a) the first Conext XW+ Inverter/Charger (INV1) and
 - b) the battery bank.

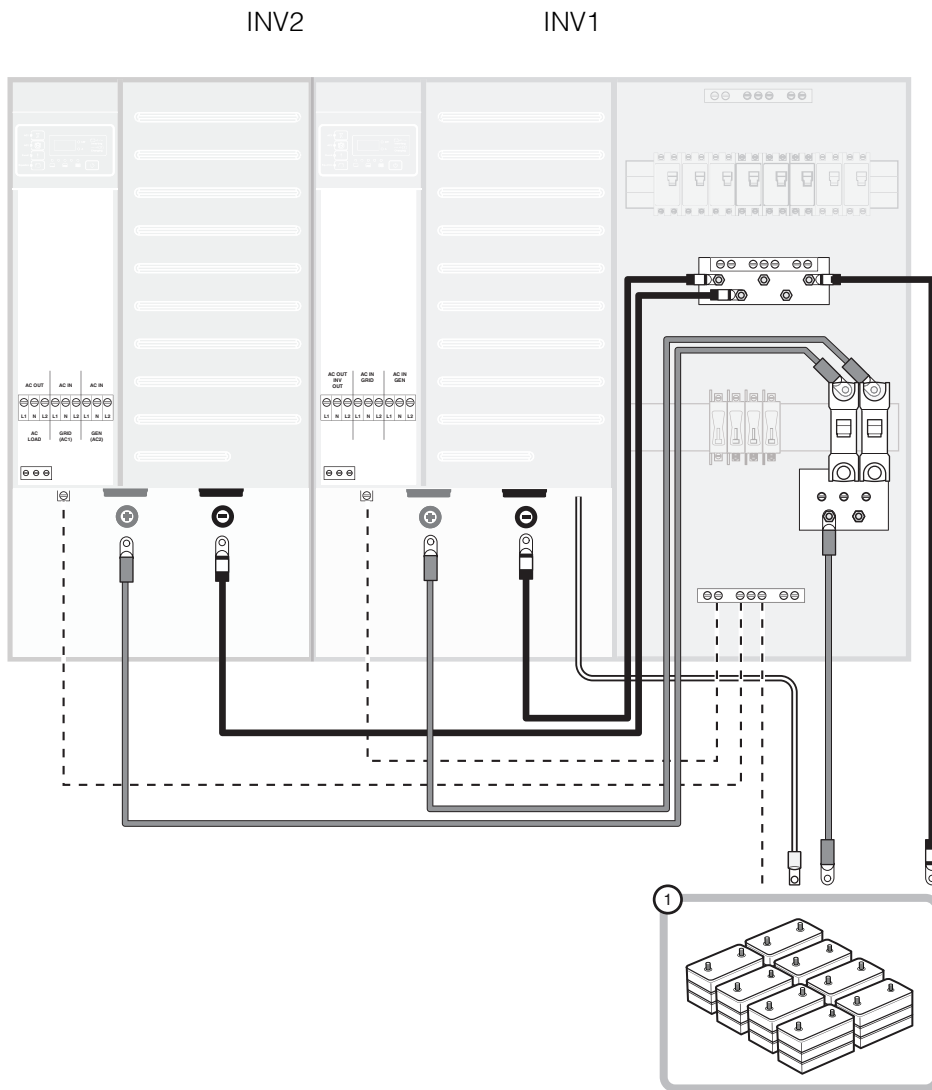

Note: Before connecting the DC cables from the PDP to the battery, perform the procedures in “AC Wiring for a Dual-Inverter System” on page 3–44.

2. Connect the positive battery cable for INV2 (included with the Conext XW+ Connection Kit for INV2 INV3 PDP) to the top terminal on the second DC disconnect/breaker, as shown in Figure 3-23 on page 3–42.
3. Connect the negative battery cable for INV2 (included with the Conext XW+ Connection Kit for INV2 INV3 PDP) to the DC Negative Bus.
4. Connect the positive battery cable to the positive terminal on the second Conext XW+ (INV2) and the negative battery cable to the negative terminal on INV2.



LEGEND

1. Battery bank

- Grounding conductor
-  Positive (+) Battery cable
-  Negative (-) Battery cable

Actual wiring requirements may vary.

Cable routing may vary. See Knockout Selection on page 2-5 and Communications Network Preparation on page 2-12.

For torque values, see page 2-16 and 2-17.

Figure 3-23 DC Connections to Dual Inverter

AC equipment grounding

⚠ WARNING

UNGROUNDING EQUIPMENT

Equipment ground terminals must be reliably connected to ground by appropriately sized grounding conductors. All installations must comply with national and local codes. Consult local and national codes for specific grounding and bonding requirements.

Failure to follow these instructions can result in death or serious injury.

See “AC Equipment Grounding” on page 3–20.

Breaker installation

Wiring a second Conext XW+ requires the installation of additional 60 A, 120/240 VAC, two-pole, type QOU AC breakers (included with the Conext 120/240VAC Breaker Kit).

To install breakers for a dual-inverter system:

1. In the PDP, disconnect all AC wires (from the utility grid or generator and to the inverter load sub-panel) and remove the pre-installed two-tab power distribution jumpers connected to the top and bottom terminals on the AC breakers.
2. Remove bypass interlock bracket.
3. Disconnect INV1 AC LOAD (INV1 L1-LOAD, INV1 L2-LOAD) wires from the top terminals on right-hand side breaker.

Note: Ensure that the neutral (INV1 N-LOAD) wiring remains connected, as shown in “AC wiring the Conext XW+ Power Distribution Panel to the Conext XW+ Inverter/Charger” on page 3–22.

4. Install the dual-pole AC breakers (included with the Conext 120/240VAC Breaker Kit) onto the DIN rail, next to the pre-installed dual-pole AC breakers in the PDP.

- Attach the four, four-tab jumpers (included in the Conext XW+ Connection Kit for INV2 INV3 PDP) to top and bottom of AC breakers as shown in Figure 3-24.

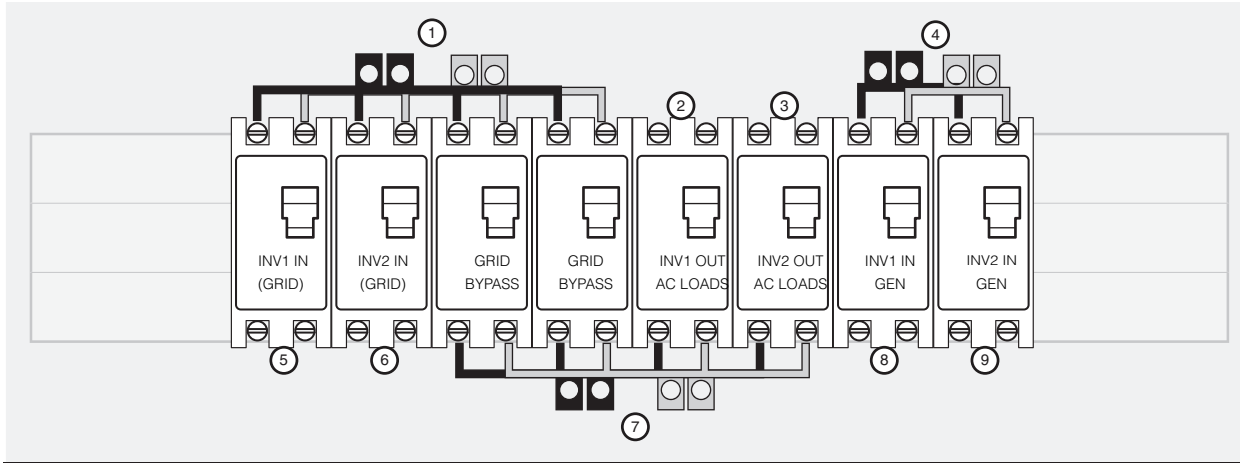

1. From main utility panel

NOTE: Install L1 power distribution bar (jumper) in first Grid breaker slot facing FRONT.

2. From AC Load on INV1

3. From AC Load on INV2

4. From generator disconnect
NOTE: Install L1 jumper in first Gen breaker slot facing REAR.

5. To AC1 on INV1

6. To AC1 on INV2

7. To inverter load sub-panel

NOTE: Install L1 jumper in first Bypass breaker slot facing REAR.

8. To AC2 on INV1

9. To AC2 on INV2

Figure 3-24 Dual Inverter AC Breaker Arrangement with Multiple AC Input Sources

Note: If a backup generator or other secondary AC source is installed in the system, reuse two of the dual-tab jumpers previously installed on INV1 Grid/Bypass breakers for generator breakers.

AC Wiring for a Dual-Inverter System

- Connect the grid wiring and inverter load sub-panel wiring to the new jumpers as shown in Figure 3-25 on page 3-45.
- Connect INV1 LOAD (INV1 L1-LOAD, INV1 L2-LOAD), INV2 LOAD (INV2 L1-LOAD, INV2 L2-LOAD), and INV2 GRID (INV2 L1-GRID, INV2 L2-GRID) wires to AC breakers as shown in Figure 3-25 on page 3-45.
- Connect neutral (INV2 N-LOAD) and ground (INV2 GROUND) wiring as shown in Figure 3-25 on page 3-45.
- Remove the knockouts on the upper faceplate of the PDP to accommodate additional breakers.
- Re-label the AC breakers with the appropriate labels, included with the Conext XW+ Power Distribution Panel.
- Install the custom designed bypass interlock plate, as shown in Figure 3-26 on page 3-46.

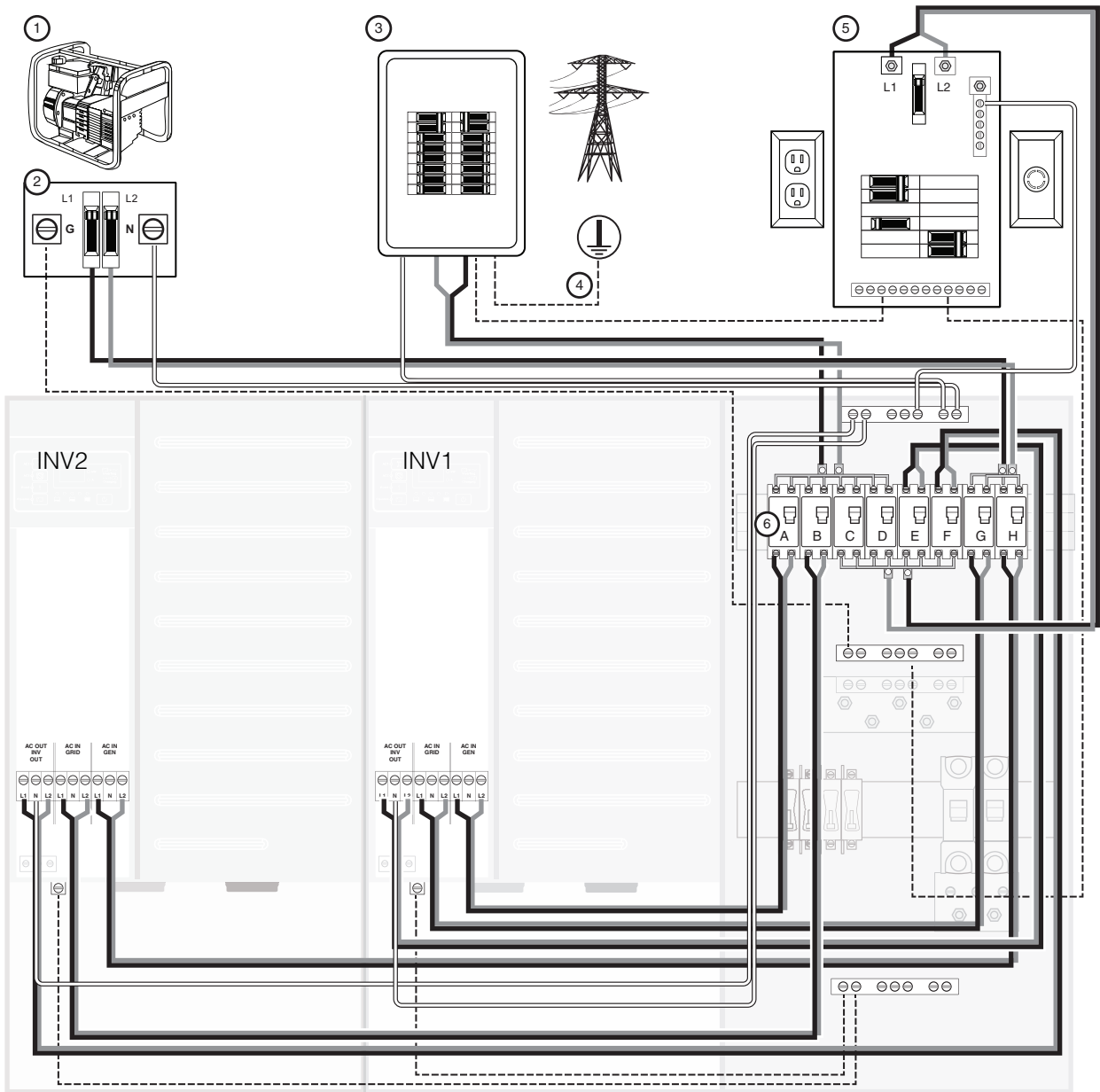

LEGEND

- 1. AC generator
- 2. Generator disconnect
- 3. Main utility panel
- 4. Grounding electrode connector
- 5. Inverter load sub-panel
- 6. AC breakers
- A. INV1 IN (Grid)
- B. INV2 iN Grid
- C. Grid bypass

- D. Grid bypass
- E. INV1 OUT (AC loads)
- F. INV2 OUT (AC loads)
- G. INV1 IN (Gen)
- H. INV2 IN (Gen)
- Hot L1
- Hot L2
- Neutral

----- Ground

Actual wiring requirements may vary.
 Cable routing may vary. See Knockout Selection on page 2-5 and Communications Network Preparation on page 2-12.
 For torque values, see page 2-16 and 2-17.
 For torque connections to the battery terminals, consult the battery manufacturer's recommendations.

Figure 3-25 AC Wiring for Dual-Inverter Systems

Bypass Interlock Plate Installation

To install the custom designed bypass interlock plate:

1. Replace the upper and lower faceplates on the PDP.
2. Ensure the breakers are in the down position and place the bypass interlock plate over the breakers, as shown in Figure 3-26, and secure it in place with the hardware provided.
3. To set it in Normal position, slide the bypass plate to the right, as shown in Figure 3-26.

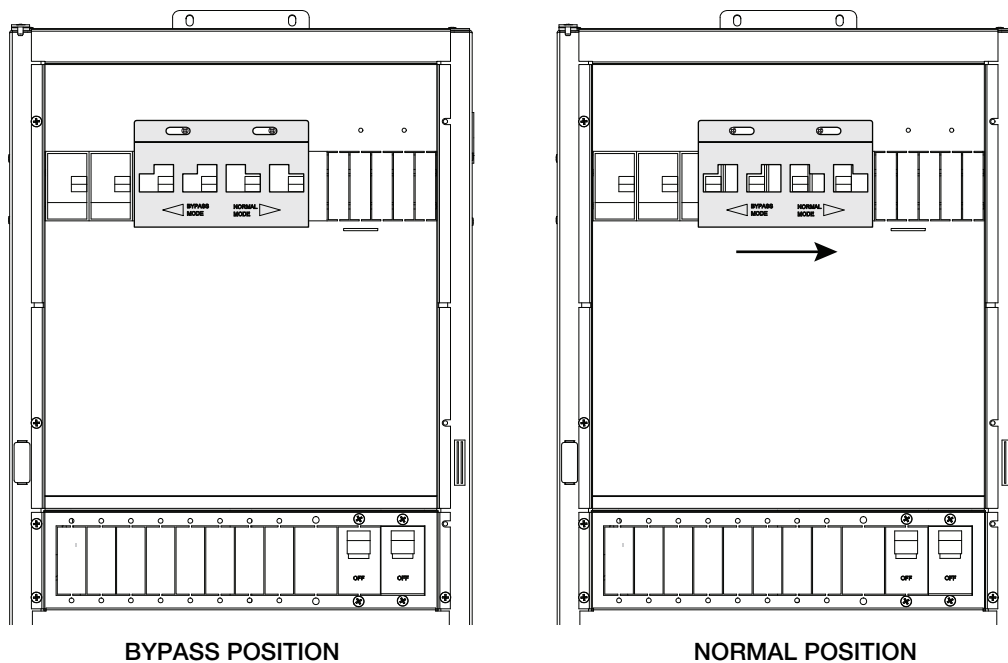

Figure 3-26 Installing the custom designed bypass interlock plate

Triple Inverter/Charger Installation

This section provides instructions for adding a second and third Conext XW+ Inverter/Charger to your installation. Complete the following installation steps only after you have already connected the PDP to the first Conext XW+, as shown in “Wiring the Conext XW+ Inverter/Charger with a PDP” on page 3-7.

DC grounding

⚠ WARNING

UNGROUNDING EQUIPMENT

Equipment ground terminals must be reliably connected to ground by appropriately sized grounding conductors. All installations must comply with national and local codes. Consult local and national codes for specific grounding and bonding requirements.

Failure to follow these instructions can result in death or serious injury.

See "Grounding the DC System" on page 3–8.

DC Positive Bus Bar installation

1. Remove the existing bus bar from the bottom terminal of the GJ250A 160 VDC, 3/8" stud DC disconnect/breaker (pre-installed in the PDP).
2. Install a second and third GJ250A - DC rated breaker (included with each Conext XW+ Connection Kit for INV2 INV3 PDP) next to the existing DC disconnect/breaker.
3. Install the DC positive bus bar included with the Conext XW+ Connection Kit for INV2 INV3 PDP. (This DC positive bus bar supports up to three GJ250A - DC rated breakers.)
4. Remove the appropriate knockouts from the Conext XW+ Power Distribution Panel lower faceplate.

Note: Replace faceplates after AC and DC wiring is complete.

DC Wiring for a Triple-Inverter System

Note: One pair of battery cables is included with each Conext XW+ Connection Kit for INV2 INV3 PDP and Conext XW+ Power Distribution Panel.

1. Using the instructions provided in "Making DC Connections" on page 3–11, make DC connections from the Conext XW+ Power Distribution Panel to:
 - a) the first Conext XW+ Inverter/Charger (INV1) and
 - b) the battery bank.

Note: Before connecting the DC cables from the PDP to the battery, perform the procedures in "AC Wiring for a Triple-Inverter System" on page 3–50.

2. Connect the positive battery cable for INV2 (included with the Conext XW+ Connection Kit for INV2 INV3 PDP) to the top terminal on the second DC disconnect/breaker.
3. Connect the negative battery cable for INV2 (included with the Conext XW+ Connection Kit for INV2 INV3 PDP) to the DC Negative Bus.

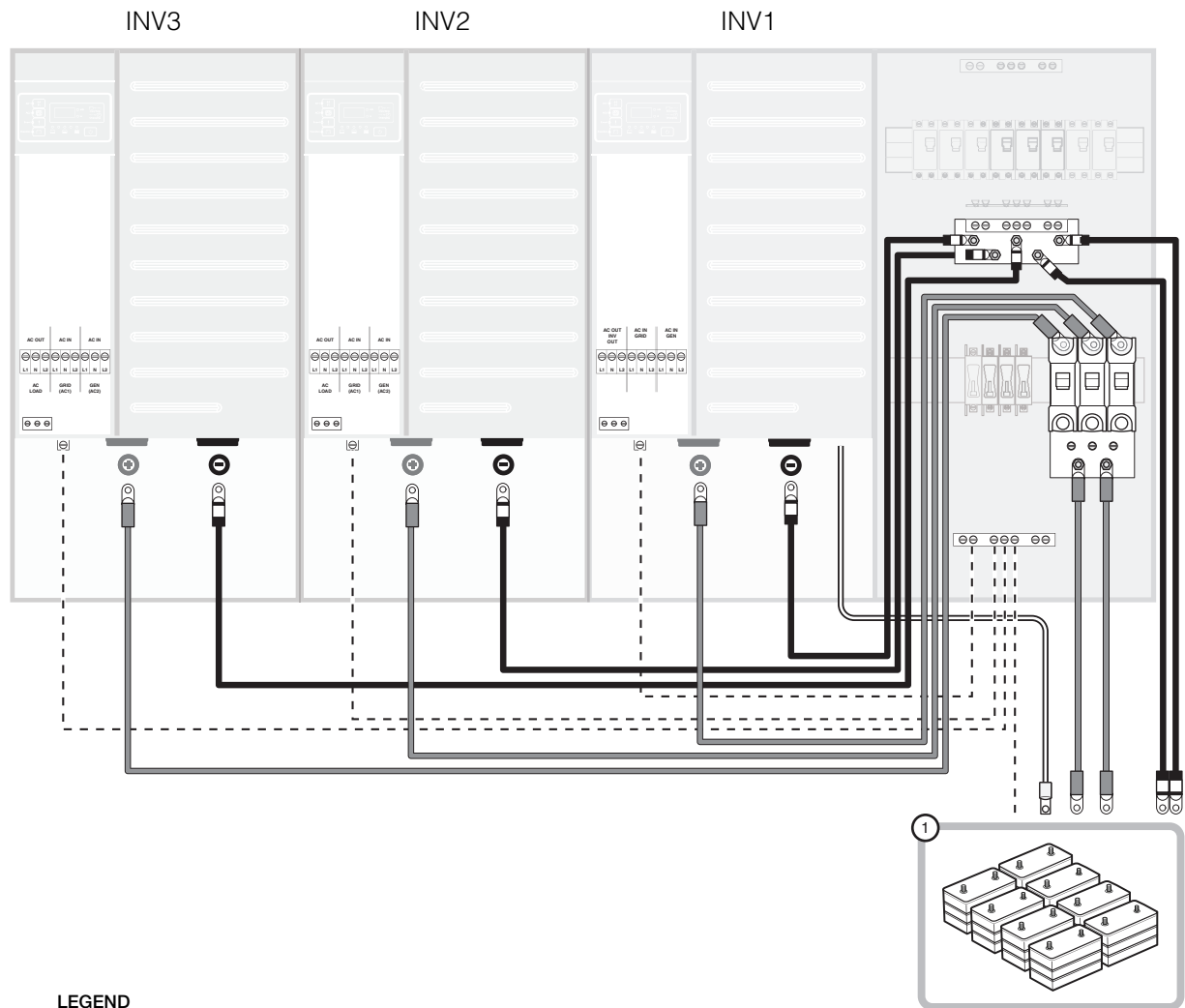

4. Connect the positive battery cable to the positive terminal on the second Conext XW+ (INV2) and the negative battery cable to the negative terminal on INV2.
5. Connect the positive battery cable for INV3 (included with the Conext XW+ Connection Kit for INV2 INV3 PDP) to the top terminal on the third DC disconnect/breaker.
6. Connect the negative battery cable for INV3 (included with the Conext XW+ Connection Kit for INV2 INV3 PDP) to the DC Negative Bus.
7. Connect the positive battery cable to the positive terminal on INV3 and the negative battery cable to the negative terminal on INV3.

Note: Before connecting the DC cables from the PDP to the battery, perform the procedures in “AC Wiring for a Triple-Inverter System” on page 3-50.



LEGEND

- 1. Vented battery enclosure
- Grounding conductor
- BTS cable

-  Positive (+) Battery cable
-  Negative (-) Battery cable

Actual wiring requirements may vary.
 Cable routing may vary. See Knockout Selection on page 2-5 and Communications Network Preparation on page 2-12.
 For torque values, see page 2-16 and 2-17.

Figure 3-27 DC Connections for a Triple-Inverter System

Power Distribution Jumper Preparation (for Triple-Inverter System Only)

Each Conext XW+ Connection Kit for INV2 INV3 PDP includes four, four-tab power distribution jumpers. In a triple-inverter system, only three tabs per jumper are needed.

Depending on your installation, you will need either:

- Four jumpers for an installation with a single AC source (AC1 or AC2), or
- Six jumpers for an installation with two AC sources(AC1 and AC2).

Cut away one of the four tabs on each jumpers that you will need for your installation.

Breaker Installation

Wiring a second and third Conext XW+ requires the installation of 60 A, 120/240 VAC, two-pole, type QOU AC breakers (included with the Conext 120/240VAC Breaker Kits).

To install breakers for a triple-inverter system:

1. In the PDP, disconnect all AC wires (from the utility grid or generator and to the inverter load sub-panel) and remove the pre-installed two-tab jumpers connected to the top and bottom terminals on the AC breakers.
2. Remove bypass interlock bracket.
3. Disconnect INV1 AC LOAD (INV1 L1-LOAD, INV1 L2-LOAD) wires from the top terminals on right-hand side breaker.

Note: Ensure that the neutral (INV1 N-LOAD) wiring remains connected, as shown in “AC wiring the Conext XW+ Power Distribution Panel to the Conext XW+ Inverter/Charger” on page 3-22.

4. Mount the 60 A, 120/240 VAC, two-pole, type QOU AC breakers onto the DIN rail, as shown in Figure 3-28 on page 3-51 and Figure 3-29 on page 3-52.
5. Install two jumpers, L1 and L2 at the output (bottom) terminals of the INV1, INV2, and INV3 AC Load breakers.
6. Install two jumpers, L1 and L2 at the input (top) terminals of the INV1, INV2, and INV3 Grid breakers. (See Figure 3-28 on page 3-51.)
7. If the installation includes a second AC source, install two jumpers, L1, and L2 at the input (top) terminals of the INV1, INV2, and INV3 Gen breakers. (See Figure 3-28 on page 3-51.)

AC equipment grounding

See “AC Equipment Grounding” on page 3-20.

AC Wiring for a Triple-Inverter System

Note: For illustrations of the following wiring arrangements, see Figure 3-28 on page 3-51 and Figure 3-29 on page 3-52.

1. Connect L1 and L2 AC wiring from each INV Grid breaker to the corresponding AC Input (AC1) terminal on each of the three Conext XW+ Inverter/Chargers.
2. If the installation includes a second AC source, connect L1 and L2 AC wiring from each INV Gen breaker to the corresponding AC Input (AC2) terminal on each of the three Conext XW+ Inverter/Chargers.

3. Connect L1 and L2 AC wiring from each INV AC Load terminal from each of the three inverters to the corresponding AC INV Out breaker terminal in the PDP.
4. Connect L1 and L2 AC Load wiring to the INV Out (AC Load) jumper.
5. If the installation includes a second AC source, connect L1 and L2 AC wiring from the Generator (or other source) disconnect to the Gen breaker jumpers.
6. Connect L1 and L2 AC wiring from the Utility Grid distribution panel to the Grid breaker jumpers.
7. Connect the neutral wiring from INV1, INV2, and INV3 to the neutral bus bar in the PDP.
8. Connect the ground wiring from INV1, INV2, and INV3 to the ground bus bar in the PDP.
9. Re-label the AC breakers with the appropriate labels, included with the Conext XW+ Power Distribution Panel.
10. Install the custom designed bypass interlock plate, as shown in Figure 3-26 on page 3-46.

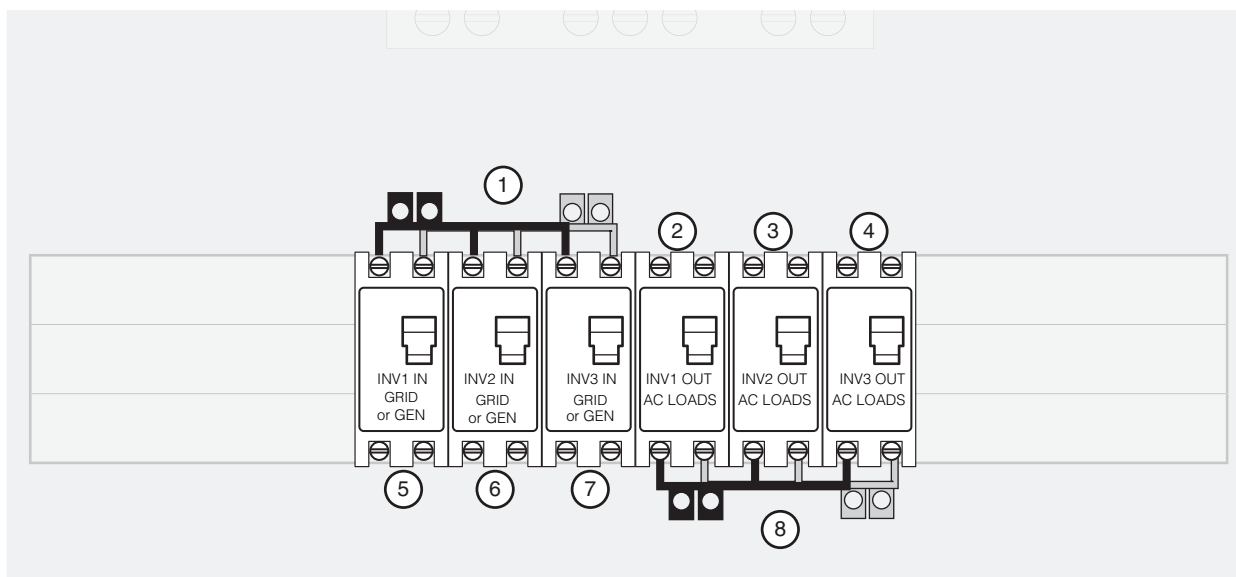

1. From AC source disconnect or transfer switch
NOTE: Install L1 power distribution bar (jumper) in first GRID/GEN breaker slot facing FRONT.

2. From AC Load on INV1
3. From AC Load on INV2
4. From AC Load on INV3
5. To AC1 or AC2 on INV1
6. To AC1 or AC2 on INV2
7. To AC1 or AC2 on INV3

8. To Inverter main utility panel or transfer switch
NOTE: Install L1 jumper in first Bypass breaker slot facing REAR

Figure 3-28 Triple-Inverter AC Breaker Arrangement with a Single AC Input Source

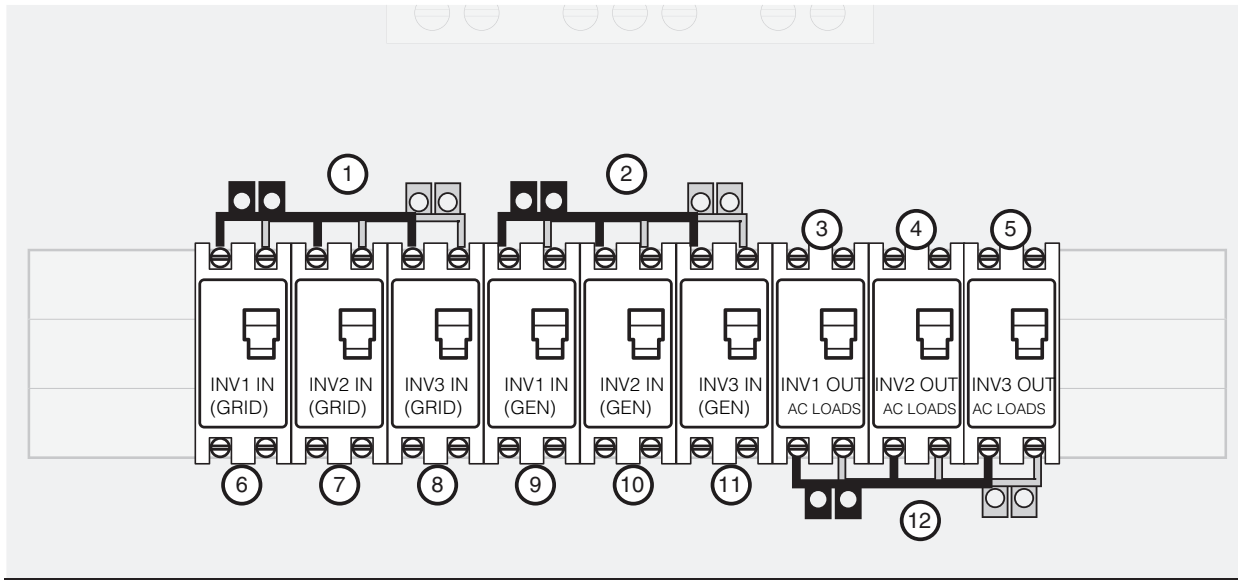

1. From main AC distribution panel or transfer switch

NOTE: Install L1 power distribution bar (jumper) in first GRID/GEN breaker slot facing FRONT.

2. From generator disconnect
3. From AC Load on INV1

4. From AC Load on INV2
5. From AC Load on INV3

6. To AC1 on INV1
7. To AC1 on INV2
8. To AC1 on INV3
9. To AC2 on INV1

10. To AC2 on INV2
11. To AC2 on INV3

12. To Inverter main utility panel or transfer switch

NOTE: Install L1 jumper in first Bypass breaker slot facing REAR

Figure 3-29 Triple-Inverter AC Breaker Arrangement with Two AC Input Sources

External Bypass Switch Installation

Note: The Conext XW+ Power Distribution Panel does not have enough breaker locations to accommodate bypass breakers in a triple-inverter system. Therefore, an external bypass switch may be needed. For an example of an External Bypass Switch installation, see Figure 3-30 on page 3-53.

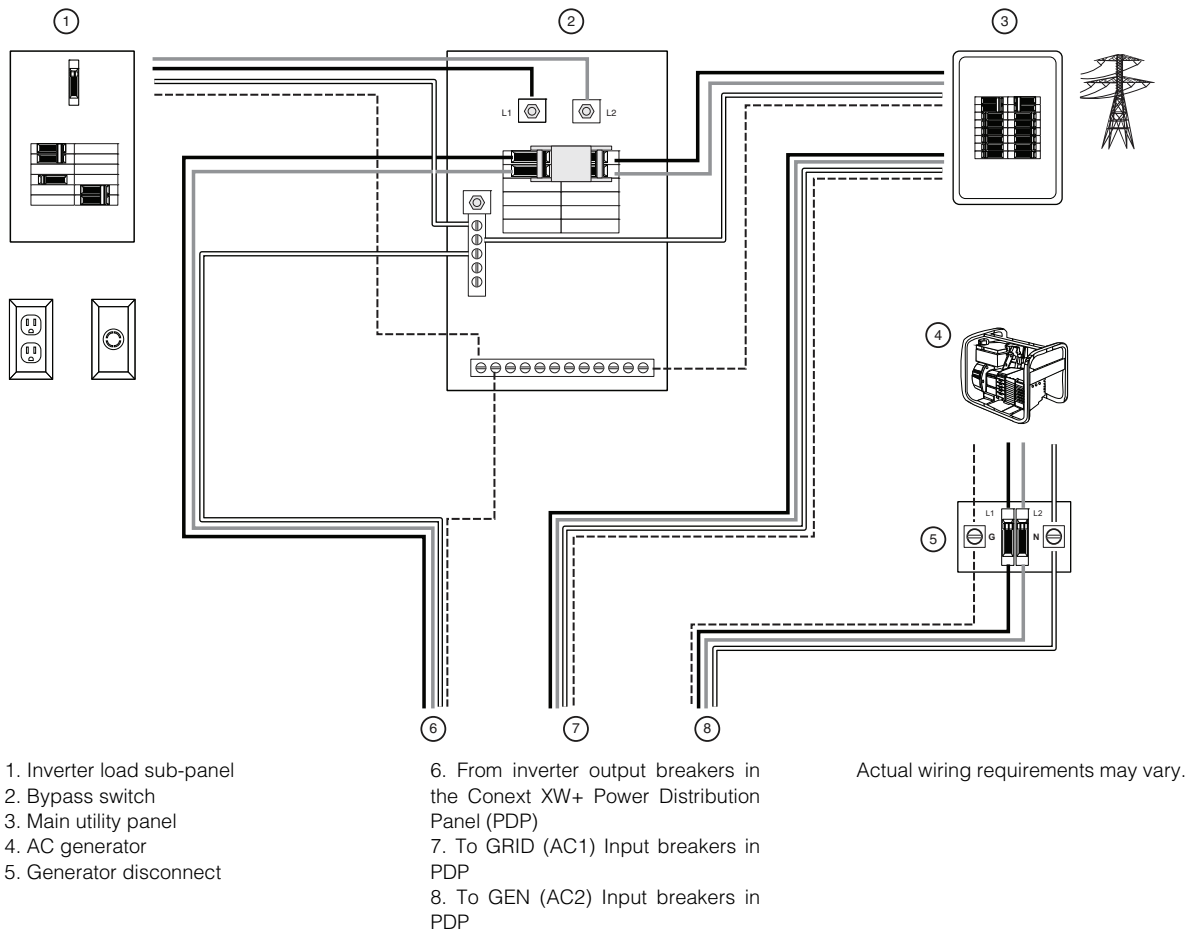

Figure 3-30 Wiring an External Bypass Switch for a Triple-Inverter Configuration

Basic Functional Test - Multiple Inverters

The following steps will complete a basic functional test of multiple Conext XW+ Inverter/Chargers. If any test fails, please refer to the Troubleshooting section in the *Conext XW+ Inverter/Charger Owner's Guide* for assistance.

To perform a functional test on multiple inverters:

1. Check/verify all wiring and cable connections.
2. Measure DC voltage at the DC terminals on the inverter and confirm it is within range and has correct polarity. The default acceptable range is 46 to 64 VDC for 48 V systems.
3. Switch INV1 DISCONNECT to the ON position.
4. Check inverter display for startup self-test during which LEDs will flash momentarily. Once self-test is complete, the inverter will display `5t6`. (The Fault/Warning LED may flash for a few seconds but eventually will turn off. If Fault/Warning LED persists, check to make sure a battery temperature sensor is connected. Also, if the inverter has been pre-configured, it may go straight into normal operating mode.)
5. Using the Conext System Control Panel, set the First (Master) Inverter Device Number:
 - a) Go to the inverter's `Advanced Settings` menu by pressing `Down arrow + Enter` from the `System Status` screen and then simultaneously pressing `Enter + Up arrow + Down arrow`.
 - b) Select `Multi Unit Config` menu.
 - c) Change `Dev Number` from `00` to `01`. The inverter will now appear as `XW6848-01` in the device list.
 - d) Press `Exit` to go back to the `System Status` screen.
6. Switch INV2 DISCONNECT to the ON position.
7. Check inverter display for startup self-test during which LEDs will flash momentarily. Once self-test is complete, the inverter will display `5t6`. (If the inverter has been pre-configured, it may go straight into normal operating mode or display `F66` warning.)
8. Using the Conext System Control Panel, set the Second (Slave) Inverter Device Number and Inverter Mode:
 - a) Select the new inverter, `XW6848-00`, in the device list.
 - b) Go to the inverter's `Advanced Settings > Multi-Unit Config` menu.
 - c) Change `Dev Number` from `00` to `02` (or the next number that has not been used). The inverter will now appear as `XW6848-02` in the device list.
 - d) Change `Invtr Mode` from `SplitPhMaster` to `SplitPhSlave`.
 - e) Press `Exit` until you see the `System Status` screen.
9. Check for faults. If fault condition(s) exist, correct and restart Functional Test.
10. If a third inverter is installed, repeat steps to configure it as a Slave.

11. Using the Conext System Control Panel, enable the system:
 - a) Go to the *System Settings* menu.
 - b) Change *System Mode* to *Operating*.
 - c) Press *Exit* until you see the *System Status* screen.
12. Confirm the Master inverter displays 0.00 and the Slaves displays “---” on their front panels.
13. Check for faults. If fault condition(s) exist, correct, and then restart Functional Test.
14. Check voltage at AC LOAD terminals of the Master inverter.
15. Switch the AC Load breakers ON.
16. Confirm operation of connected AC loads.
17. Disconnect AC LOAD breakers.
18. Using the Conext System Control Panel, reduce maximum charge rate.
 - a) From the *System Status* screen, go to *System Settings* and enable *Cascading* (if not enabled). With *Cascading* enabled, a change to a setting in one inverter will automatically ripple through to the other inverter(s) in the system.
 - b) Go to *Advanced Settings > Charger Settings* in one of the inverters.
 - c) Set *Max Chg Rate* to 10%.
 - d) Press *Exit* until you see the *System Status* screen.
19. Switch AC input breakers ON.

Note: All inverters in the system must be connected to the same AC input source before they will qualify the source.
20. Confirm both inverters start charging.

Note: With *Max Chg Rate* set to 10% the maximum charge rate is limited to 10 A on each inverter. Depending on the battery bank’s state-of-charge, the output from one or more inverters may quickly drop to zero. This is considered normal operation.
21. Check for faults. If fault condition(s) exist, correct, and then restart the Functional Test.

If the Inverters pass the Functional Test, proceed to the Commissioning procedure as defined in *Conext XW+ Inverter/Charger Owner’s Guide*.

Wiring a Balanced Three-Phase System

This section provides instructions for wiring the AC and DC connections in the Conext XW+ Power Distribution Panel (PDP) and Conext XW+ for a balanced three-phase system.

Note: Converting from 120 V/240 V split-phase to 120 V single-phase is required if the inverters are used in systems with single-phase (2-wire 120 V) or three-phase (208/120 V) sources. For more information, see Appendix C, “Split-Phase to Single-Phase Conversion Instructions”.

Pre-Installation Steps

DANGER

HAZARD OF ELECTRIC SHOCK, EXPLOSION, OR ARC FLASH

- Apply appropriate personal protective equipment (PPE) and follow safe electrical work practices. See NFPA 70E or CSA Z462.
- This equipment must only be installed and serviced by qualified electrical personnel.
- Never operate energized with covers removed
- Energized from multiple sources. Before removing covers identify all sources, de-energize, lock-out, and tag-out and wait 2 minutes for circuits to discharge
- Always use a properly rated voltage sensing device to confirm all circuits are de-energized.

Failure to follow these instructions will result in death or serious injury.

DANGER

HAZARD OF ELECTRIC SHOCK, EXPLOSION, OR ARC FLASH

- Remove watches, rings, or other metal objects.
- This equipment must only be installed and serviced by qualified electrical personnel.
- Keep sparks and flames away from the batteries.
- Use tools with insulated handles.
- Wear protective glasses, gloves and boots.
- Do not lay tools or other metal parts on top of batteries.

Failure to follow these instructions will result in death or serious injury.

⚠ DANGER

HAZARD OF ELECTRIC SHOCK, EXPLOSION, OR ARC FLASH

- Battery Circuit Breakers must be installed according to the specifications and requirements defined by Schneider Electric.
- Servicing of batteries must only be performed by qualified personnel knowledgeable of batteries and the required precautions. Keep unqualified personnel away from batteries.
- Disconnect the charging source prior to connecting or disconnecting battery terminals.

Failure to follow these instructions will result in death or serious injury.

Before installing a three-phase system, disconnect all power from the system.

Depending on your installation, you will need to perform the following pre-installation steps:

1. Convert each 120 V/240 V, three-wire, split-phase Conext XW+ model to single-phase. For more information, see Appendix C, “Split-Phase to Single-Phase Conversion Instructions”.
2. Wall-mount Conext XW+ Inverter/Chargers and PDP. See “Wall-Mounting the Conext XW+ and PDP” on page 2–9.
3. Install Conext XW+ Conduit Box as needed. See “Installing the Conext XW+ Conduit Box” on page 2–10.
4. Install AC sync and Xanbus cable(s) as needed. See “Installing AC sync and Xanbus cables” on page 4–5.
5. Remove knockouts on the PDP as needed to accommodate the wiring. See “Knockout Selection” on page 2–4 for more information about knockouts.

Conext XW+ Inverter/Charger Grounding

▲ WARNING
UNGROUNDING EQUIPMENT
Equipment ground terminals must be reliably connected to ground by appropriately sized grounding conductors. All installations must comply with national and local codes. Consult local and national codes for specific grounding and bonding requirements.
Failure to follow these instructions can result in death or serious injury.

The Conext XW+ is provided with ground terminals that must be reliably connected to ground (protective earth) by appropriately sized equipment grounding conductors. System grounding for the AC and DC systems must be done according to all applicable NEC and local installation codes.

For more information about system grounding, see “Grounding the DC System” on page 3–8 and “AC Equipment Grounding” on page 3–20.

DC Wiring for a Three-Phase System

Battery cables

Battery cables are not included in the Conext XW+ Inverter/Charger package. Depending on your installation requirements, you will need to supply at least one pair of battery cables. For battery cable requirements, see “Battery Cable Requirements” on page 2–14.

Note: One pair of #4/0 AWG Arctic Ultraflex Blue™ battery cables is included with each Conext XW+ Power Distribution Panel and Conext XW+ Connection Kit for INV2 INV3 PDP. For more information, see “Optional Accessories” on page 1–5.

⚠ DANGER

HAZARD OF ELECTRIC SHOCK, EXPLOSION, OR ARC FLASH

- Apply appropriate personal protective equipment (PPE) and follow safe electrical work practices. See NFPA 70E or CSA Z462.
- This equipment must only be installed and serviced by qualified electrical personnel.
- Never operate energized with covers removed
- Energized from multiple sources. Before removing covers identify all sources, de-energize, lock-out, and tag-out and wait 2 minutes for circuits to discharge
- Always use a properly rated voltage sensing device to confirm all circuits are de-energized.

Failure to follow these instructions will result in death or serious injury.

⚠ DANGER

HAZARD OF ELECTRIC SHOCK, EXPLOSION, OR ARC FLASH

- Remove watches, rings, or other metal objects.
- This equipment must only be installed and serviced by qualified electrical personnel.
- Keep sparks and flames away from the batteries.
- Use tools with insulated handles.
- Wear protective glasses, gloves and boots.
- Do not lay tools or other metal parts on top of batteries.

Failure to follow these instructions will result in death or serious injury.

⚠ DANGER**HAZARD OF ELECTRIC SHOCK, EXPLOSION, OR ARC FLASH**

- Battery Circuit Breakers must be installed according to the specifications and requirements defined by Schneider Electric.
- Servicing of batteries must only be performed by qualified personnel knowledgeable of batteries and the required precautions. Keep unqualified personnel away from batteries.
- Disconnect the charging source prior to connecting or disconnecting battery terminals.

Failure to follow these instructions will result in death or serious injury.

⚠ WARNING**OVERHEATING OF DC TERMINALS AND CABLES**

Overheating of the DC terminals or DC cables to dangerous temperatures may occur due to improper installation.

- Do not put anything between the cable lug and the terminal surface.
- Do not over-tighten connections; observe all recommended torque values.
- Do not apply any type of anti-oxidant paste until after the cable connection is tightened.
- Do not under size cables; install cables sized in accordance with national electrical code requirements.
- DC cables must have crimped copper compression lugs or crimped and soldered copper compression lugs; soldered connections alone are not acceptable. Lugs must be rated for use with fine-stranded cable.
- Do not use coarse-stranded cable; the lack of flexibility may pull DC terminal connections loose.

Failure to follow these instructions can result in death or serious injury.

For more information about battery cables, see “Battery cables” on page 3–11.

Note: When making DC connections, be sure to observe correct hardware stacking and proper polarity, and ensure that nothing obstructs the connection between the terminal surface and the battery cable lug. (See Figure 3-8 on page 3–14.)

DC grounding

See “Grounding the DC System” on page 3–8.

DC Positive Bus Bar installation

1. Remove the existing bus bar from the bottom terminal of the GJ250A 160 VDC, 3/8" stud DC disconnect/breaker (pre-installed in the PDP).
2. Install a second and third GJ250A - DC rated breaker (included with each Conext XW+ Connection Kit for INV2 INV3 PDP) next to the existing DC disconnect/breaker.
3. Install the DC positive bus bar included with the Conext XW+ Connection Kit for INV2 INV3 PDP. (This DC positive bus bar supports up to three GJ250A - DC rated breakers.)
4. Remove the appropriate knockout from the Conext XW+ Power Distribution Panel lower faceplate.

Note: Replace faceplates after AC and DC wiring is complete.

DC Wiring for a Balanced Three-Phase System

Note: One pair of battery cables is included with each Conext XW+ Connection Kit for INV2 INV3 PDP and Conext XW+ Power Distribution Panel.

1. Using the instructions provided in "Making DC Connections" on page 3-11, make DC connections from the Conext XW+ Power Distribution Panel to:
 - a) the first Conext XW+ Inverter/Charger (INV1) and
 - b) the battery bank.

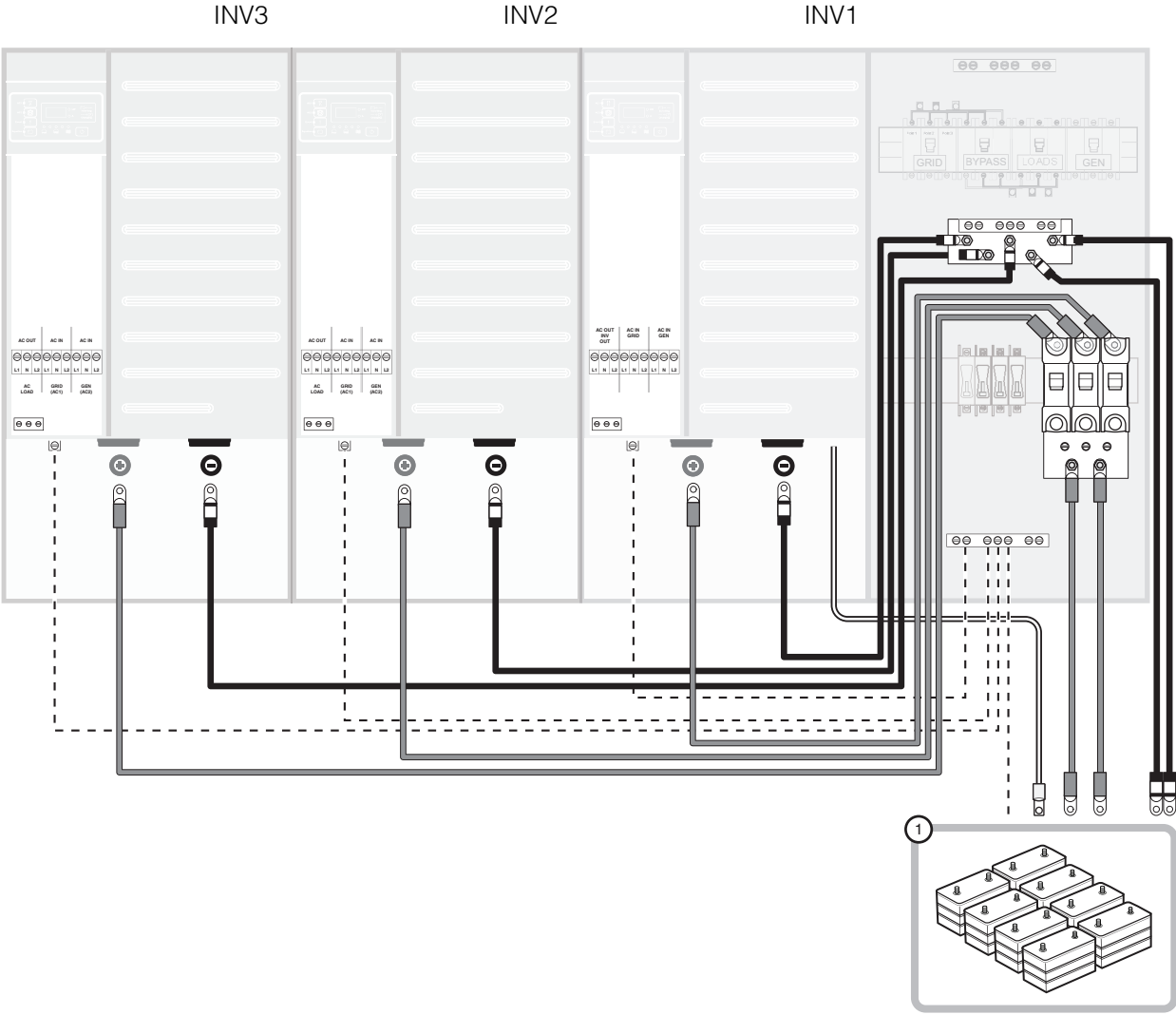

Note: Before connecting the DC cables from the PDP to the battery, perform the procedures in "AC Wiring for a Three-Phase System" on page 3-65.

2. Connect the positive battery cable for INV2 (included with the Conext XW+ Connection Kit for INV2 INV3 PDP) to the top terminal on the second DC disconnect/breaker.
3. Connect the negative battery cable for INV2 (included with the Conext XW+ Connection Kit for INV2 INV3 PDP) to the DC Negative Bus.
4. Connect the positive battery cable to the positive terminal on the second Conext XW+ (INV2) and the negative battery cable to the negative terminal on INV2.
5. Connect the positive battery cable for INV3 (included with the Conext XW+ Connection Kit for INV2 INV3 PDP) to the top terminal on the third DC disconnect/breaker.
6. Connect the negative battery cable for INV3 (included with the Conext XW+ Connection Kit for INV2 INV3 PDP) to the DC Negative Bus.
7. Connect the positive battery cable to the positive terminal on INV3 and the negative battery cable to the negative terminal on INV3.

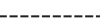

LEGEND

- 1. Vented battery enclosure
-  BTS cable
-  Grounding conductor

-  Positive (+) Battery cable
-  Negative (-) Battery cable

Actual wiring requirements may vary.
 Cable routing may vary. See Knockout Selection on page 2-5 and Communications Network Preparation on page 2-12.
 For torque values, see page 2-16 and 2-17.

Figure 3-31 Three-Phase DC Wiring

Breaker Installation

1. Remove all connections to the utility grid, generator, inverter load sub-panel, and Conext XW+ Inverter/Charger.
2. Remove the pre-installed breakers from the PDP, and mount the 3-pole, 60 A, 120/208 VAC breakers (included in the Conext 3 Phase Breaker Kit) onto the DIN rail.

3. In the PDP, attach six two-tab power distribution jumpers in the AC breaker positions as shown in Figure 3-32 on page 3-64.

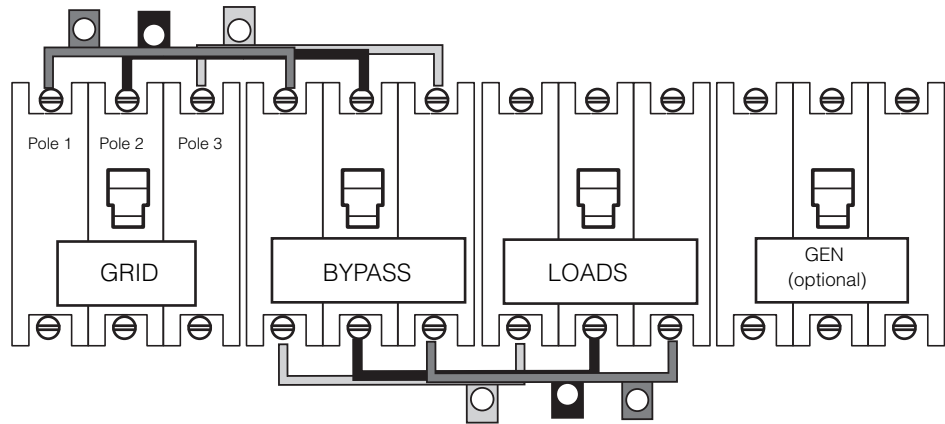

Figure 3-32 Power Distribution Jumper Installation (Three-Phase)

4. Connect the AC wiring as shown in Figure 3-33.

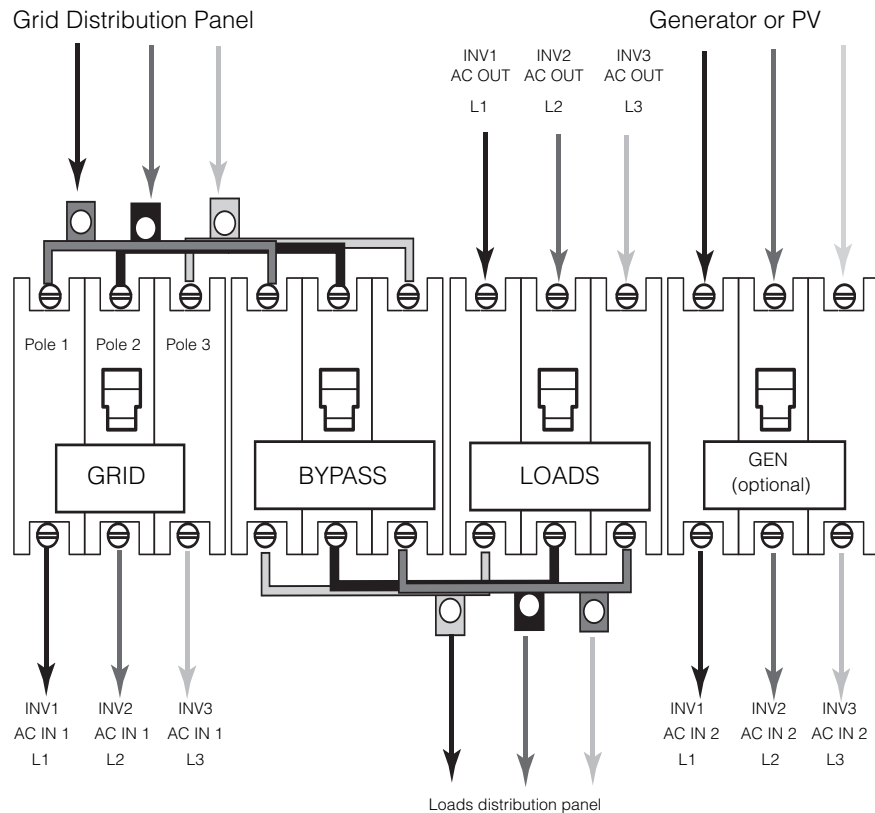

Figure 3-33 PDP Three-Phase AC Wiring

AC equipment grounding

See “AC Equipment Grounding” on page 3–20.

AC Wiring for a Three-Phase System

To connect the Conext XW+ Power Distribution Panel to the Conext XW+ Inverter/Chargers:

- 1. Connect the L1 AC wiring from each pole on the GRID breaker to the corresponding AC Input (AC1) terminal on each of the Conext XW+ units.
- 2. Connect the L1 AC wiring from each pole on the LOAD breaker to the corresponding AC OUT terminal on each of the Conext XW+ units.
- 3. Connect the L1 AC wiring from the LOADS breaker jumpers to the AC LOADS panel.
- 4. Connect the L1 AC wiring from the utility grid distribution panel to the GRID breaker jumpers.
- 5. If the installation includes a generator or second AC source, connect the L1 AC wiring from each pole on the GEN breaker to the corresponding AC Input (AC2) terminal on each of the three Conext XW+ units.

To connect the Conext XW+ units to each other:

- 1. Connect the AC Wiring in the master inverter/charger (INV1) terminal block. See Figure 3-34. Connect INV2 and INV3 the same way.

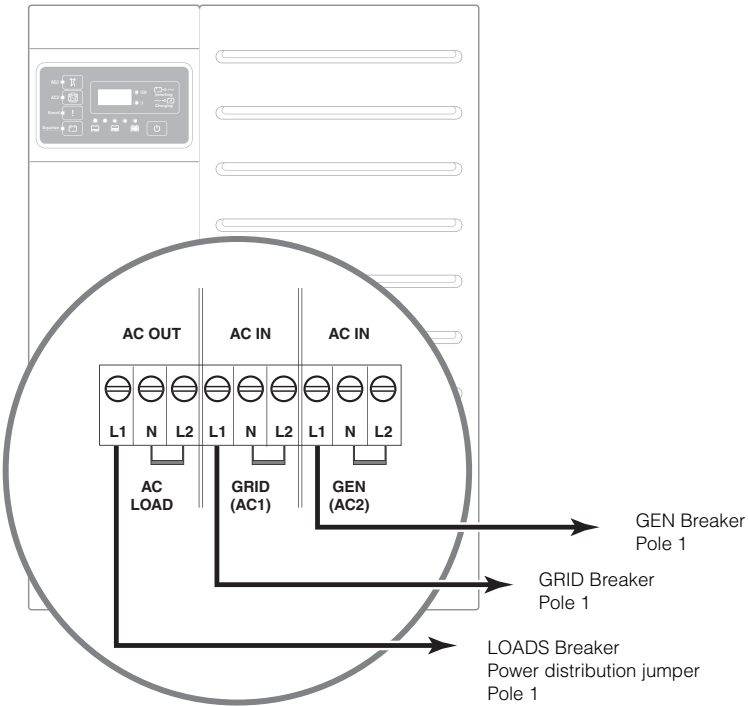

Figure 3-34 Inverter/Charger Three-Phase AC Wiring

2. Connect neutral wiring from INV1, INV2, and INV3 to the neutral bus bar on the PDP.
3. Connect ground wiring from INV1, INV2, and INV3 to the ground bus bar on the PDP.
4. Using the labels included with the PDP, re-label the AC breakers as appropriate.
5. Install the bypass interlock plate, as shown in figure “Bypass Interlock Plate Installation (Three-Phase)” on page 3–66.

Bypass Interlock Plate Installation (Three-Phase)

To install the custom designed bypass interlock plate:

1. Replace the upper and lower faceplates on the PDP.
2. Place the bypass interlock plate over the breakers, as shown in Figure 3-35, and secure it in place with the hardware provided.
3. To set it in Normal position, slide the bypass plate to the right, as shown in Figure 3-35.

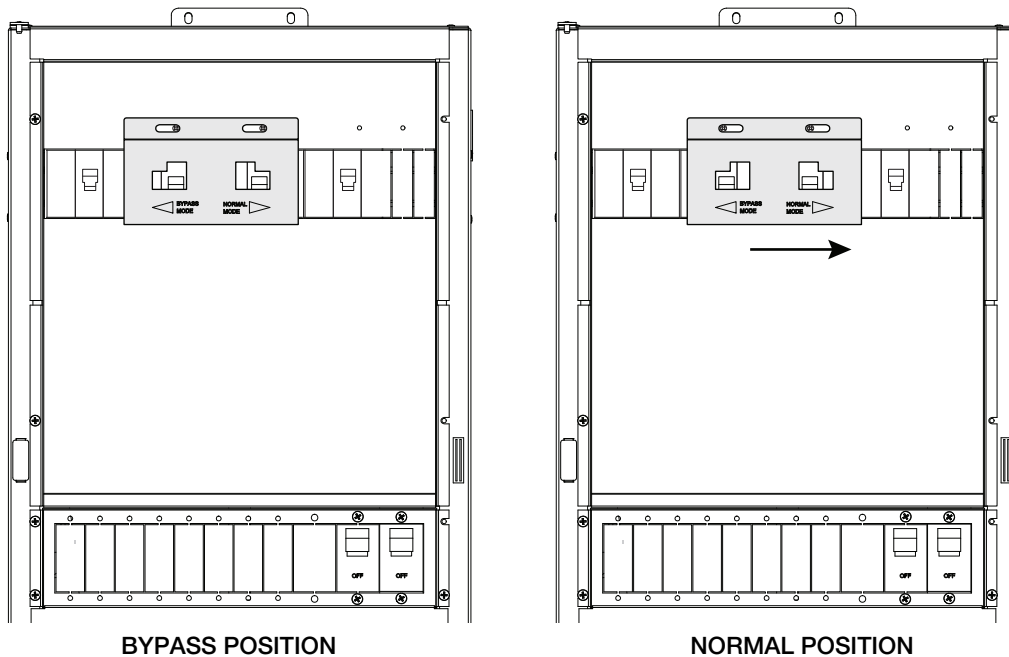

Figure 3-35 Installing the custom designed three-phase bypass interlock plate

Wiring the Conext XW+ Inverter/Charger without a PDP

⚠ DANGER

HAZARD OF ELECTRIC SHOCK, EXPLOSION, OR ARC FLASH

- Apply appropriate personal protective equipment (PPE) and follow safe electrical work practices. See NFPA 70E or CSA Z462.
- This equipment must only be installed and serviced by qualified electrical personnel.
- Never operate energized with covers removed
- Energized from multiple sources. Before removing covers identify all sources, de-energize, lock-out, and tag-out and wait 2 minutes for circuits to discharge
- Always use a properly rated voltage sensing device to confirm all circuits are de-energized.

Failure to follow these instructions will result in death or serious injury.

⚠ DANGER

HAZARD OF ELECTRIC SHOCK, EXPLOSION, OR ARC FLASH

- Remove watches, rings, or other metal objects.
- This equipment must only be installed and serviced by qualified electrical personnel.
- Keep sparks and flames away from the batteries.
- Use tools with insulated handles.
- Wear protective glasses, gloves and boots.
- Do not lay tools or other metal parts on top of batteries.

Failure to follow these instructions will result in death or serious injury.

⚠ DANGER

HAZARD OF ELECTRIC SHOCK, EXPLOSION, OR ARC FLASH

- Battery Circuit Breakers must be installed according to the specifications and requirements defined by Schneider Electric.
- Servicing of batteries must only be performed by qualified personnel knowledgeable of batteries and the required precautions. Keep unqualified personnel away from batteries.
- Disconnect the charging source prior to connecting or disconnecting battery terminals.

Failure to follow these instructions will result in death or serious injury.

This section provides illustrations for wiring the AC and DC connections for a Conext XW+ without a Conext XW+ Power Distribution Panel.

Pre-Installation Steps

Depending on your installation, you will need to perform some or all of some the following pre-installation steps:

1. Prepare the battery bank. See “Battery Bank Preparation” on page 2–13.
2. Wall-mount the Conext XW+ Inverter/Chargers. See “Wall-Mounting the Conext XW+ and PDP” on page 2–9.
3. Install Conext XW+ Conduit Box as needed. See “Installing the Conext XW+ Conduit Box” on page 2–10.
4. Install AC sync and Xanbus cable(s) as needed. See “Installing AC sync and Xanbus cables” on page 4–5.
5. Remove knockouts on the Conext XW+ as needed to accommodate the wiring. See “Knockout Selection” on page 2–4 for more information about knockouts.

Feed-in Protection Requirements

NOTICE

OVERLOADING THE DISTRIBUTION PANEL

The amount of power that can be fed into a distribution panel and the means and location for feed-in, must be in accordance with NEC 2008 article 690.64 or the current requirements of the local electrical code.

Failure to follow these instructions can result in damage to equipment.

Conext XW+ Inverter/Charger Grounding

▲ WARNING

UNGROUNDING EQUIPMENT

Equipment ground terminals must be reliably connected to ground by appropriately sized grounding conductors. All installations must comply with national and local codes. Consult local and national codes for specific grounding and bonding requirements.

Failure to follow these instructions can result in death or serious injury.

The Conext XW+ is provided with ground terminals that must be reliably connected to ground (protective earth) by appropriately sized equipment grounding conductors. System grounding for the AC and DC systems must be done according to all applicable NEC and local installation codes.

For more information about system grounding, see “Grounding the DC System” on page 3–8 and “AC Equipment Grounding” on page 3–20.

Grounding the DC System

To connect the Conext XW+ to the DC grounding system, use the ground lug at the bottom of the Conext XW+ chassis (see “Conext XW+ Features” on page 1–4). The terminal accepts wires from #14 AWG (1.63 mm) to #2 AWG (6.54 mm).

System grounding for the DC system, which typically involves bonding (connecting) the battery negative circuit to ground, is dependent on the system configuration.

Note: If a grounded DC system is required, ensure that the system bonding is done in one location only, and that all conductors and connections comply with all applicable NEC and local installation codes.

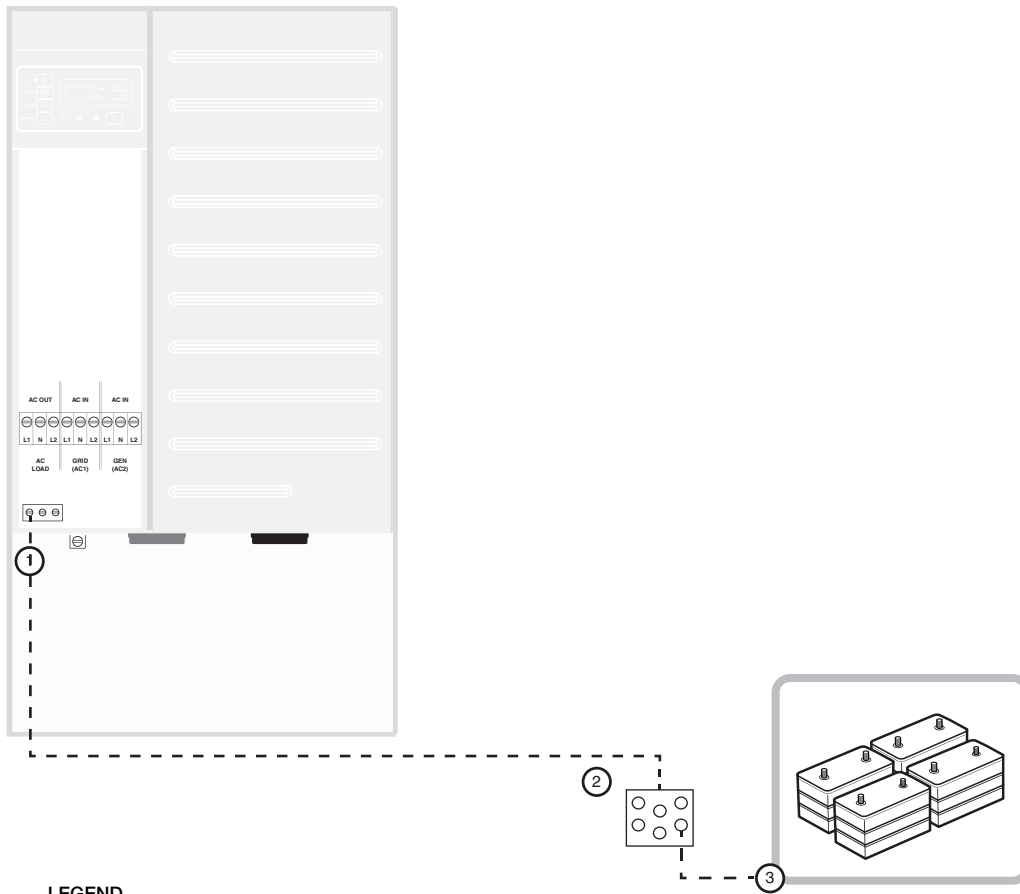

LEGEND

- 1. AC Ground bar
- 2. Negative ground/bus
- 3. Vented battery enclosure

Actual wiring requirements may vary.

Cable routing may vary. See Knockout Selection on page 2-5 and Communications Network Preparation on page 2-12.

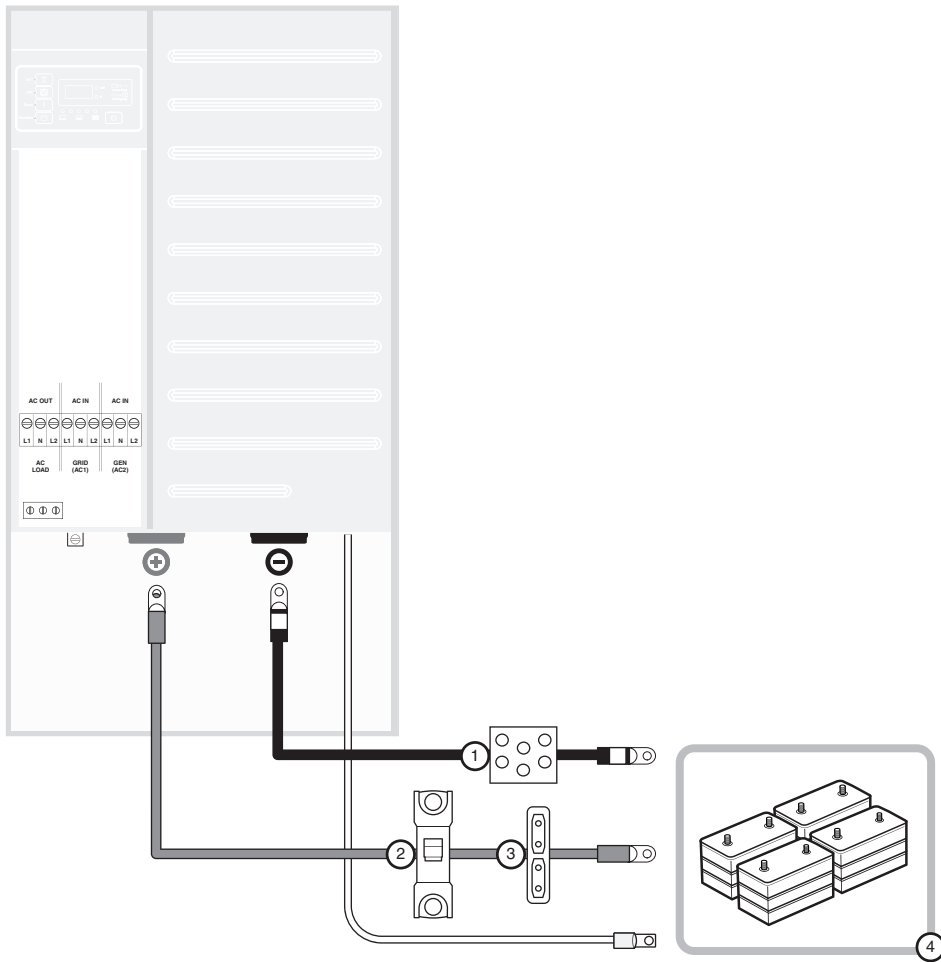

For torque values, see page 2-16 and 2-17.

Figure 3-36 Grounding the DC System (No PDP)



LEGEND

- 1. Negative ground/bus
- 2. Circuit breaker/DC disconnect
- 3. Fuse block (optional)
- 4. Vented battery enclosure

-  BTS cable
-  Positive (+) Battery cable
-  Negative (-) Battery cable

Actual wiring requirements may vary.
 Cable routing may vary. See Knockout Selection on page 2-5 and Communications Network Preparation on page 2-12.
 For torque values, see page 2-16 and 2-17.

Figure 3-37 DC Connections to a Single Inverter (No PDP)

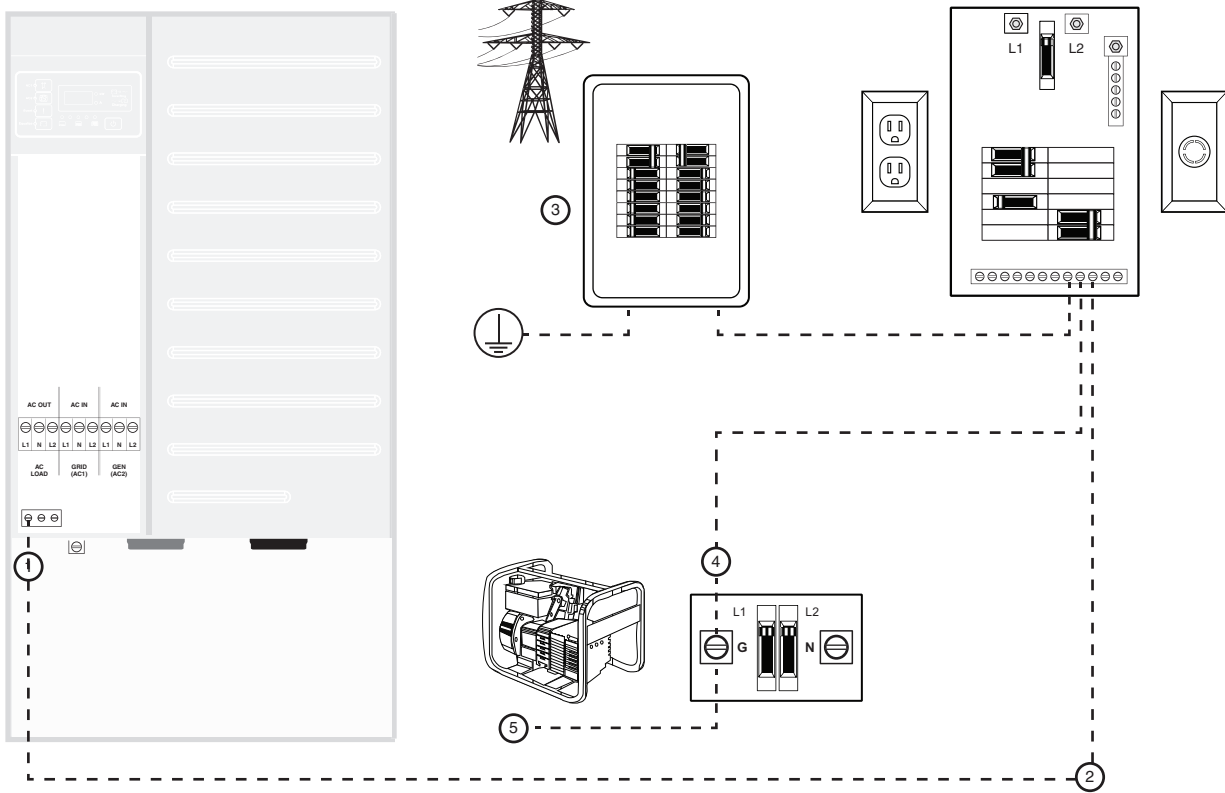

LEGEND

- 1. To AC ground bar
- 2. To inverter load sub-panel
- 3. To main utility panel

- 4. Generator disconnect
- Note: Depending on the location of the generator and local code requirements, the generator disconnect may be located in the power distribution panel.
- 5. To AC generator

Grounding requirements may vary.
Cable routing may vary. See Knockout Selection on page 2-5 and Communications Network Preparation on page 2-12. For torque values, see page 2-16 and 2-17.

Figure 3-38 Grounding the AC System (No PDP)

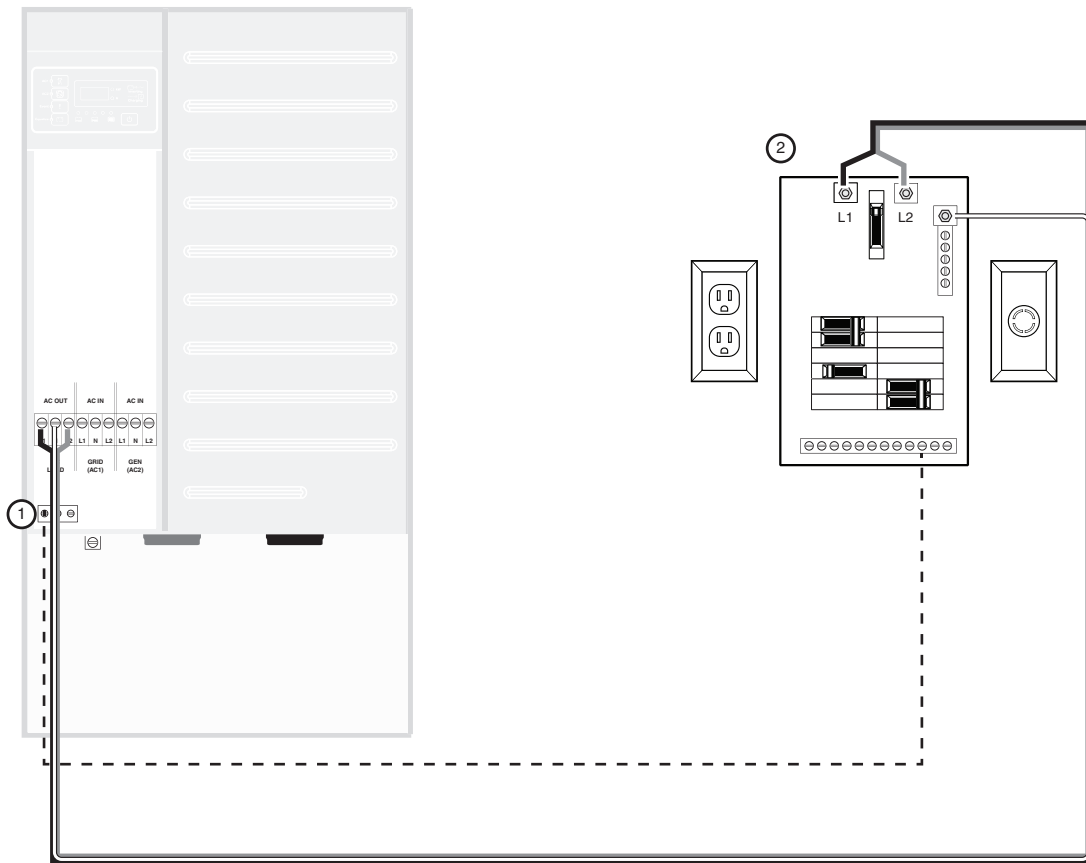

LEGEND

- 1. AC ground bar
- 2. Inverter load sub-panel

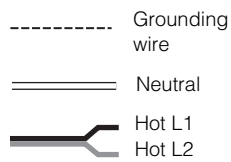

Actual wiring requirements may vary.
 Cable routing may vary. See Knockout Selection on page 2-5 and Communications Network Preparation on page 2-12.
 For torque values, see page 2-16 and 2-17.

Figure 3-39 AC Output Wiring to the Inverter Load Sub-Panel (No PDP)

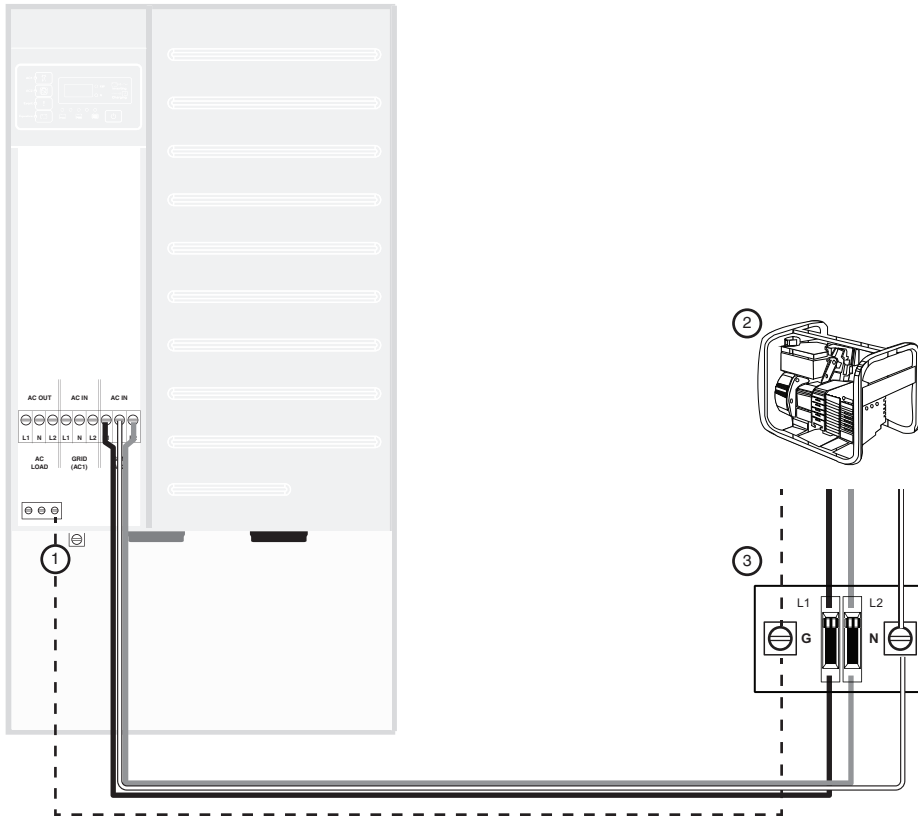

LEGEND

- 1. AC ground bar
- 2. Generator
- 3. Generator disconnect

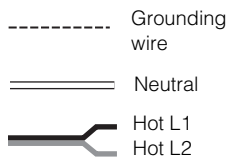

Actual wiring requirements may vary.

Cable routing may vary. See Knockout Selection on page 2-5 and Communications Network Preparation on page 2-12.

For torque values, see page 2-16 and 2-17.

Figure 3-40 Generator Wiring directly to the Inverter (No PDP)

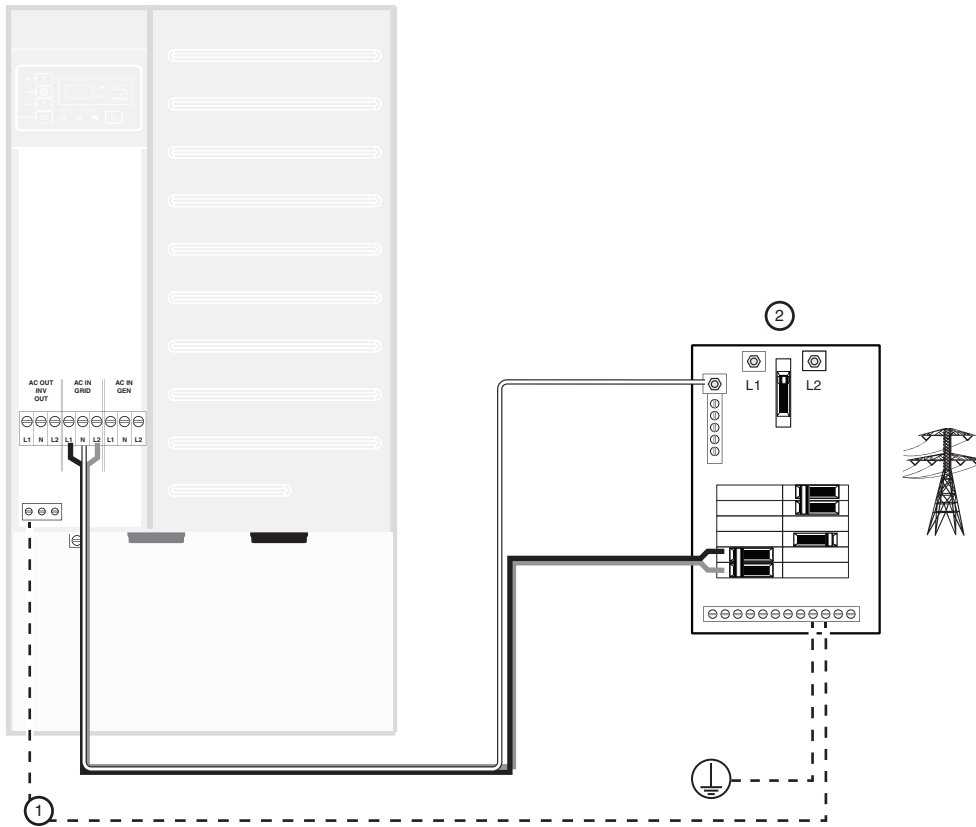

LEGEND

- 1. AC ground bar
- 2. Main utility panel

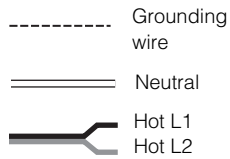

Actual wiring requirements may vary.
 Cable routing may vary. See Knockout Selection on page 2-5 and Communications Network Preparation on page 2-12.
 For torque values, see page 2-16 and 2-17.

Figure 3-41 Utility Wiring to the Inverter Input (No PDP)

4

Xanbus Network Installation

Chapter 4, “Xanbus Network Installation” provides detailed information for planning and installing the components necessary for network communication on a Xanbus system.

Topics in this chapter include:

- “The Xanbus Network” on page 4–2
- “Installing the Network” on page 4–4

The Xanbus Network

A Xanbus network is a collection of Xanbus enabled devices that perform individual functions, but also communicate and interact with other devices on the network. The network capability of the Conext XW+ provides a solution that simplifies and automates the installation, configuration, control, monitoring, and integration of devices.

Network Components

NOTICE	
SHORT CIRCUIT OF NETWORK COMPONENTS	
<ul style="list-style-type: none">• This network is not an ethernet system. Only connect Xanbus-enabled devices to other Xanbus-enabled devices. Do not attempt to connect Xanbus-enabled devices to other networks or systems.• Ethernet crossover cables are not compatible with the Xanbus system. Use Category 5 (CAT 5 or CAT 5e) cables to connect Xanbus-enabled devices.• Do not install network terminators in an AC Sync port.	
Failure to follow these instructions can result in damage to equipment.	

A Xanbus network consists of three elements: Xanbus-enabled devices, Xanbus power supply, and Xanbus cables.

Each device is integrated into the network using cables, network connectors, and terminators. An example of a network system is shown in Figure 4-1.

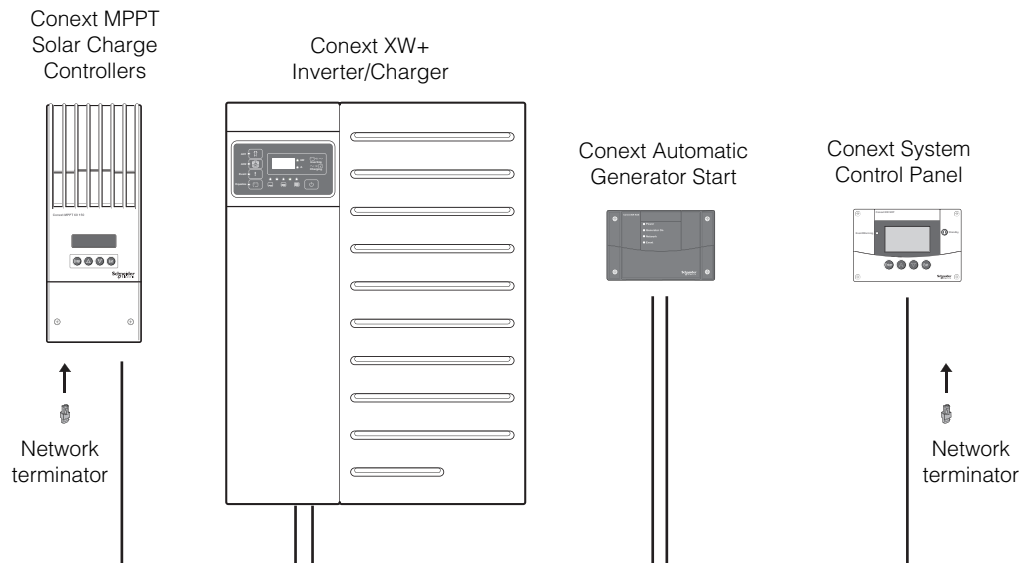

Figure 4-1 Xanbus Network System (Example)

Xanbus-enabled devices

A Xanbus-enabled device is any product that works on a Xanbus network. Below are some examples of Xanbus-enabled devices:

- Conext System Control Panel
- Conext XW+ Inverter/Charger
- Conext Automatic Generator Start
- Conext Battery Monitor
- MPPT 60 150 Solar Charge Controller
- MPPT 80 600 Solar Charge Controller

Due to network traffic, the maximum number of Conext XW+ units in a single Xanbus network should not exceed twelve. The maximum number of Conext MPPT Solar Charge Controllers in a single Xanbus network should not exceed twelve.

The combined maximum number of Conext XW+ units and Conext MPPT Solar Charge Controllers should not exceed twelve.

Xanbus power supply

Xanbus-enabled devices are either power-supplying or power-consuming. The Xanbus network needs at least one device with a power supply sufficient to run the entire network.

Note: The total network current supplied by the power-sourcing devices must be equal to or greater than the total current drawn by the power-consuming devices. The power supply must be capable of providing 15 VDC/200 mA to each device.

For example, in a system with an Conext XW+ Inverter/Charger, Conext System Control Panel, and Conext Automatic Generator Start, the Conext XW+ is a power-supplying device capable of providing 800 mA at 15 VDC while the two other devices each consume a maximum of 200 mA for a total maximum consumption of 400 mA. In this example, the network is properly configured from a power perspective because the power source is capable of providing more current than is needed: 800 mA > 400 mA.

Note: See the specifications for each Xanbus-enabled device to determine how much power each device consumes or supplies.

Xanbus cables

Each Xanbus-enabled device is connected by a Category 5 (CAT 5 or CAT 5e) cable, a standard cable available from the manufacturer or any computer supply store. The cable consists of eight conductors in four twisted pairs with an RJ45 modular connector wired to the T568A standard.

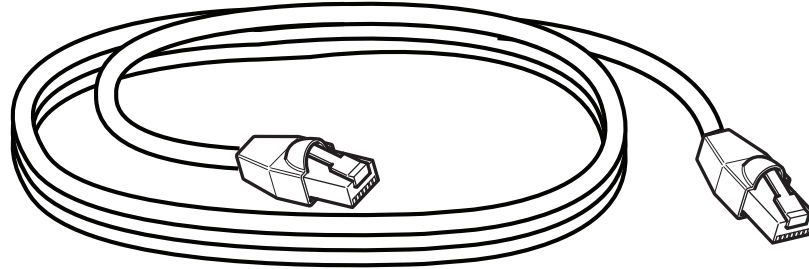

Figure 4-2 Xanbus Cable

Network terminators

The Xanbus network must be properly terminated at each end to ensure the communication signal quality on the network.

Note: If the network is not properly terminated, signal quality is degraded and performance on the network is reduced. Permanent configuration without terminators is not supported.

The Conext XW+ Inverter/Charger and other Xanbus-enabled devices ship with one network terminator. Depending on your network layout, this terminator may need to be removed from the XW+ Inverter/Charger and inserted into another device elsewhere in the network.

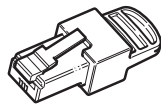

Figure 4-3 Network terminator

Installing the Network

Note: Installing and replacing Xanbus-enabled devices in an existing system must be performed with the Conext XW+ Inverter/Charger in standby mode. For more information about standby mode, see the *Conext System Control Panel Owner's Guide*.

Before You Begin the Installation

- Read the entire section before installing the network. It is important to plan the installation from beginning to end.
- Assemble all the tools and materials required for the installation.

Installation Tools and Materials

Tools A Phillips head screwdriver, appropriately sized is required to install the Xanbus cables.

Materials The following materials may be required to complete the installation.

- CAT 5 or CAT 5e cables (available from computer supply stores)
- Terminators

Note: Mount cables and network connectors in a dry location.

Installing AC sync and Xanbus cables

The AC sync cable connects each inverter and provides the necessary communication and control between multiple units. Install these cables, routing them through the Conext XW+ Conduit Box raceway, prior to making the AC and DC wiring connections.

Note: If you are installing a Xanbus-enabled device on an existing Xanbus system, put the system in standby mode using the *System Settings* menu on the Conext System Control Panel.

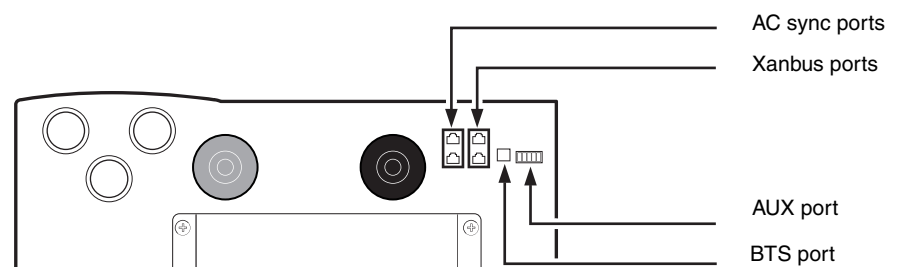

Figure 4-4 Conext XW+ Inverter/Charger communication ports

To install the AC sync and Xanbus cables:

1. Remove the two raceways for the communication cabling by removing the screw holding each raceway in place, as shown in Figure 4-5.

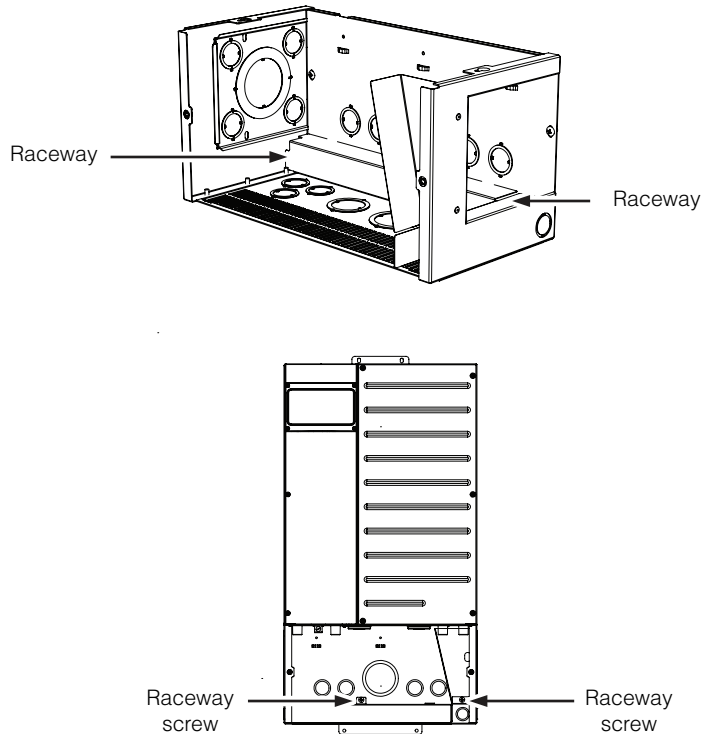

Figure 4-5 XW+ Conduit Box raceways

2. Insert the RJ45 jack on the cable into one of the two AC Sync ports.

3. Route the cable as shown in Figure 4-6. Route any additional communication cables through the raceways. Replace the wiring raceways, ensuring not to pinch the cables. Secure the raceways to the Conduit Box with the screw that was removed earlier.

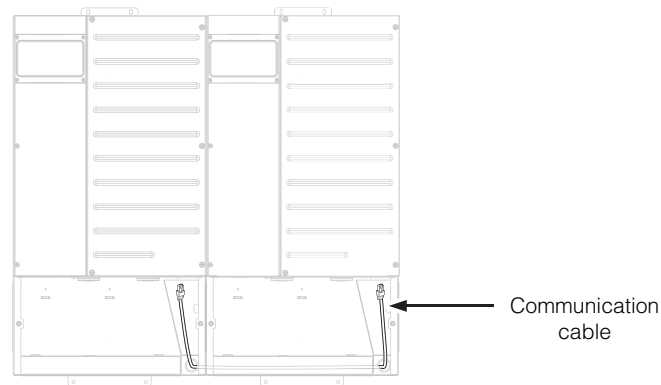

Figure 4-6 Installing the AC sync and Xanbus cables

Note: In a dual-inverter system, install an AC Sync Cable from INV1 to INV2. In a triple-inverter system, daisy-chain an AC Sync Cable from INV1 to INV2 and from INV2 to INV3.

Guidelines for Routing the Xanbus Cables

⚠ WARNING

XANBUS SHOCK HAZARD

Xanbus cables in contact with DC or AC power can transmit an electric shock. Do not route the Xanbus cables in the same conduit or panel as the AC and DC power cabling.

Failure to follow these instructions can result in death or serious injury.

To ensure maximum performance of your network, follow these guidelines when routing the Xanbus cables.

- Route the cables away from sharp edges that might damage the insulation. Avoid sharp bends in the cable—no less than a 4-inch (100 mm) radius.
- Allow at least 2 ¼ inches (57 mm) of space behind the wall to accommodate the depth of the unit and allow room for the cables to bend.
- Allow for some slack in the cable tension.
- Keep the alignment of wire pairs inside the sheath as straight as possible.
- Allow separation between data and power cables (data cables should only cross over a power cable at right angles).

- Avoid using metal cable staples. Use appropriate hardware fasteners to avoid damage to the cable.
- Support horizontal cables using J hooks or cable trays.

The total length of the network, including all connected Xanbus-enabled devices and the Conext XW+ Inverter/Charger, cannot exceed 130 feet (40 m).

5

Conext XW+ Inverter/Charger Accessories Installation

Chapter 5, “Conext XW+ Inverter/Charger Accessories Installation” provides detailed instructions for installing certain accessories for your Conext XW+ Inverter/Charger.

Topics in this chapter include:

- “Conext System Control Panel Installation” on page 5–2

Conext Combox Installation

The Conext XW+ Inverter/Charger can be controlled remotely by connecting a Conext ComBox.

The Conext ComBox allows access to programming features of the Conext XW+ and allows the system to be modified to specific installation requirements.

For installation instructions, see the *Conext Combox Owner's Guide* (975-0679-01-01).

Conext System Control Panel Installation

The Conext XW+ can be controlled remotely by connecting a Conext System Control Panel (SCP).

The SCP allows access to programming features of the Conext XW+ and allows the system to be modified to specific installation requirements.

The SCP can be connected to the Conext XW+ Inverter/Charger through one of the following two methods:

- via the Xanbus network (see “Installing the SCP via the Xanbus Network” on page 5–3), or
- by replacing the inverter information panel with the SCP (see “Replacing the Inverter Information Panel with the SCP” on page 5–4).

Installing the SCP via the Xanbus Network

▲ WARNING

IGNITION AND FIRE HAZARD

This equipment is not ignition protected. To prevent fire or explosion, do not install this product in locations that require ignition-protected equipment. This includes any confined space containing vented batteries, or flammable chemicals such as, natural gas (NG), liquid petroleum gas (LPG) or gasoline (Benzine/Petrol).

- Do not install in a confined space with machinery powered by flammable chemicals, or storage tanks, fittings, or other connections between components of fuel or flammable chemical systems.
- Do not install the inverter near readily flammable materials such as cloth, paper, straw, or plastic sheeting. Keep flammable materials a minimum distance of 600 cm (24 in.) from the top surface and 30 cm (12 in.) from either side surface and the front of the Conext XW+ Inverter/Charger.

Failure to follow these instructions can result in death or serious injury.

The SCP is connected to the Xanbus network via either of the two Xanbus network ports located at the bottom of the Conext XW+ chassis (as shown in Figure 5-1).

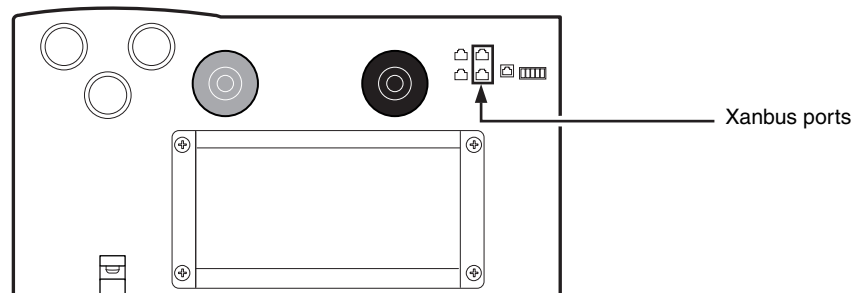

Figure 5-1 Xanbus Port Locations

For more information about installing a Xanbus-enabled device as part of a network system, see Chapter 4, “Xanbus Network Installation”.

For wall-mounting and other installation instructions, see the *Conext System Control Panel Owner's Guide* (975-0298-01-01).

Replacing the Inverter Information Panel with the SCP

To remove the inverter information panel from the Conext XW+ chassis:

⚠ DANGER

HAZARD OF ELECTRIC SHOCK, EXPLOSION, OR ARC FLASH

- Apply appropriate personal protective equipment (PPE) and follow safe electrical work practices. See NFPA 70E or CSA Z462.
- This equipment must only be installed and serviced by qualified electrical personnel.
- Never operate energized with covers removed
- Energized from multiple sources. Before removing covers identify all sources, de-energize, lock-out, and tag-out and wait 2 minutes for circuits to discharge
- Always use a properly rated voltage sensing device to confirm all circuits are de-energized.

Failure to follow these instructions will result in death or serious injury.

⚠ DANGER

HAZARD OF ELECTRIC SHOCK, EXPLOSION, OR ARC FLASH

- Remove watches, rings, or other metal objects.
- This equipment must only be installed and serviced by qualified electrical personnel.
- Keep sparks and flames away from the batteries.
- Use tools with insulated handles.
- Wear protective glasses, gloves and boots.
- Do not lay tools or other metal parts on top of batteries.

Failure to follow these instructions will result in death or serious injury.

▲ DANGER**HAZARD OF ELECTRIC SHOCK, EXPLOSION, OR ARC FLASH**

- Battery Circuit Breakers must be installed according to the specifications and requirements defined by Schneider Electric.
- Servicing of batteries must only be performed by qualified personnel knowledgeable of batteries and the required precautions. Keep unqualified personnel away from batteries.
- Disconnect the charging source prior to connecting or disconnecting battery terminals.

Failure to follow these instructions will result in death or serious injury.

1. If the AC access panel is attached to the Conext XW+ chassis, remove it (as shown in “AC Access Panel Removal” on page 3–2).
2. Remove the four screws from the inverter information panel, as shown in Figure 5-2.

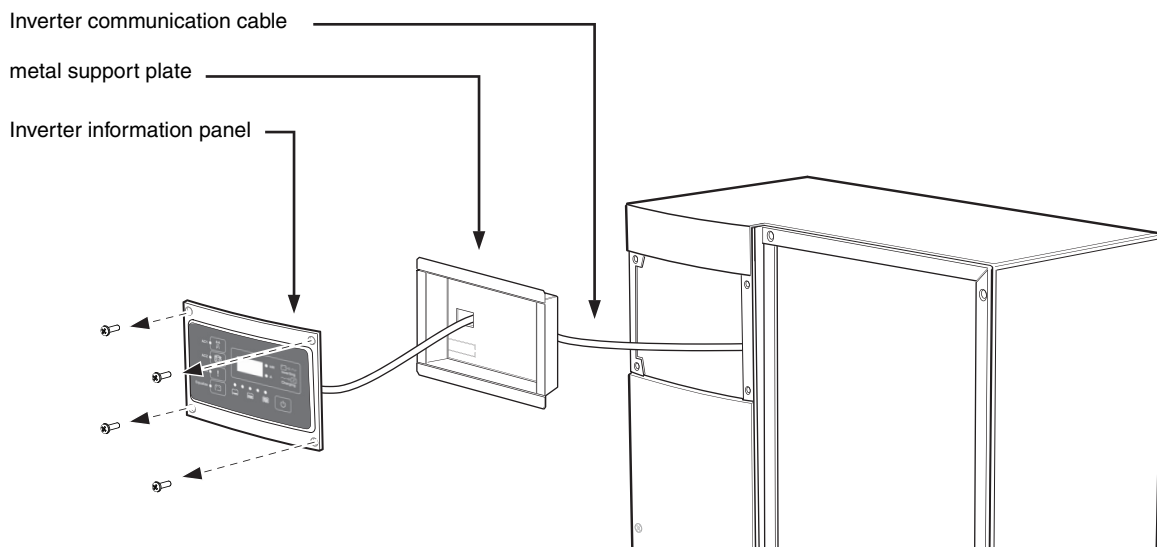

Figure 5-2 Inverter information panel removal

3. Carefully remove the inverter information panel from the Conext XW+ chassis, and detach it from the inverter communication cable.
4. Remove the metal support plate from the housing of the Conext XW+ chassis.

5. For easier access, remove the right-side panel of the Conext XW+, as shown in Figure 5-3.

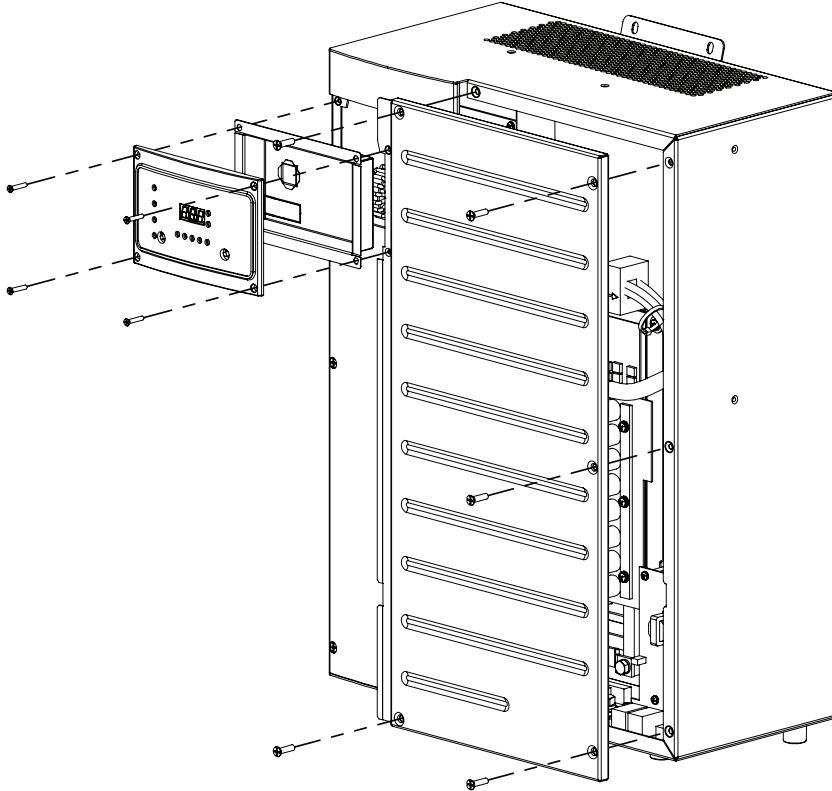

Figure 5-3 Right-side panel removal

6. Unplug the communication cable from the upper communication port

To install the SCP into the Conext XW+ chassis:

1. Plug the inverter communication cable into the lower communication port.
2. Re-secure the right-side panel (if applicable).
3. Carefully place the SCP into the housing of the Conext XW+ chassis.

- Secure the SCP with the four screws removed from the inverter information panel.

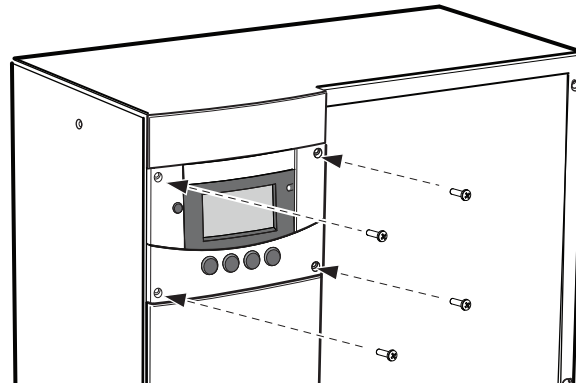

Figure 5-4 Mounting plate centered on wall studs

- When all wiring is complete, re-secure the AC access panel to the Conext XW+ chassis. For more information, see “Removing the AC Access Panel and PDP Internal Faceplates” on page 3–2.

For more information about the Conext System Control Panel, see the *Conext XW+ Inverter/Charger Operation Guide*.

Verifying the Installation

If network power (from an inverter/charger) is present, the SCP backlight will illuminate and the startup screen will appear, followed by the system Home screen. For more information, see the *Conext XW+ Inverter/Charger Operation Guide*.

A

Specifications

Appendix A, “Specifications” provides the electrical and mechanical specifications for the Conext XW+ Inverter/Charger.

Electrical Specifications

Table A-1 Conext XW+ Inverter/Charger Electrical Specifications

	Conext XW+ 6848 NA	Conext XW+ 5548 NA
Continuous Output Power	6,800 W	5,500 W
Surge Rating (Overload for 1 minute)	12,000 W	9,500 W
Surge Rating (Overload for 5 minutes)	11,000 W	9,000 W
Surge Rating (Overload for 30 minutes)	8,500 W	7,000 W
Surge Current	L-N: 104 A _{rms} (60 s) L-L: 52 A _{rms} (60 s)	L-N: 82 A _{rms} (60 s) L-L: 41 A _{rms} (60 s)
Waveform	True Sine Wave	
Idle Consumption—Inverter mode, no load	28 W	26 W
Idle Consumption—Search mode	< 8 W	
AC Output Voltage	L-N: 120 VAC ±3% L-L: 240 VAC ±3%	
AC Input Voltage range (Bypass/Charger Mode)	L-N: 78–140 VAC (120 V nominal) L-L: 160–270 VAC (240 V nominal)	
AC Input Breaker	60 A double-pole	
AC Input Frequency Range (Bypass/Charger Mode)	52–68 Hz (default) 44–70 Hz (allowable)	
AC1 voltage range—Sell Mode ^a	L-N: 105.6–132 ±1.5 V L-L: 211–264 ±3.0 V	
AC1 frequency range—Sell Mode ^a	59.4–60.4 ±0.05 Hz	
AC Output Current (maximum 75% imbalance between L1-N, L2-N) in Inverter Mode	L-N: 48 A L-L: 28 A	L-N: 46 A L-L: 23 A
AC Output Breaker	60 A double-pole	
AC Output Frequency	60.0 ±0.1 Hz	
Total Harmonic Distortion	< 5% at rated power	
Automatic Transfer Relay	60 A	
Auxiliary Relay Output	0–12 VDC, maximum 250 mA DC	
Peak Efficiency	95.7%	95.7%
CEC Weighted Efficiency	92.5%	93.0%
CEC Power Rating	6,000 W ^b 5,760 W ^c	4,400 W
DC Input Voltage (Nominal)	48 VDC	
DC Input Voltage Range	40–64 VDC	40–64 VDC
DC Current at Rated Continuous Power (Inverter Mode)	180 A	150 A
Continuous Charge Rate at L-L voltage (Charger Mode)	140 A	110 A

Table A-1 Conext XW+ Inverter/Charger Electrical Specifications

	Conext XW+ 6848 NA	Conext XW+ 5548 NA
Power Factor Corrected Charging	PF (0.98)	
Typical Transfer Time	8 ms	

- a. Automatically adjusts when entering Sell Mode. This unit or system is provided with fixed trip limits and shall not be aggregated above 30 kW on a single Point of Common Connection.
- b. Conext XW+ 6848 NA (Part Number 865-6848-01)
- c. Conext XW+ 5548 NA (Part Number 865-5548-01)

Conext XW+ Overload Capability

Loads connected to the inverter are seldom constant, and large loads are often operated for short periods. To accommodate larger loads, the Conext XW+ can temporarily exceed its continuous output power rating.

The graphs below illustrate approximate operation time versus load. Inverter operation time during overload is limited by both inverter internal temperature protection and by the product of AC output current and elapsed time.

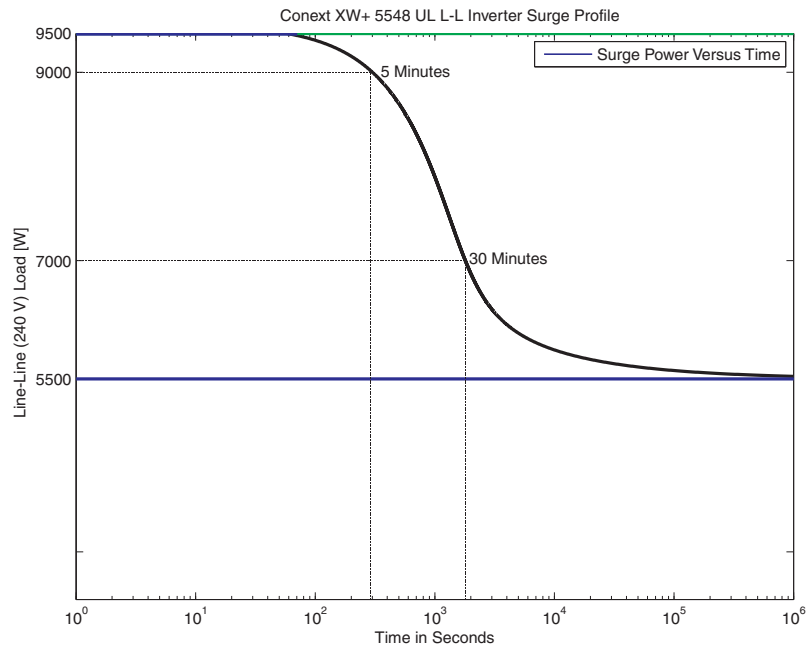

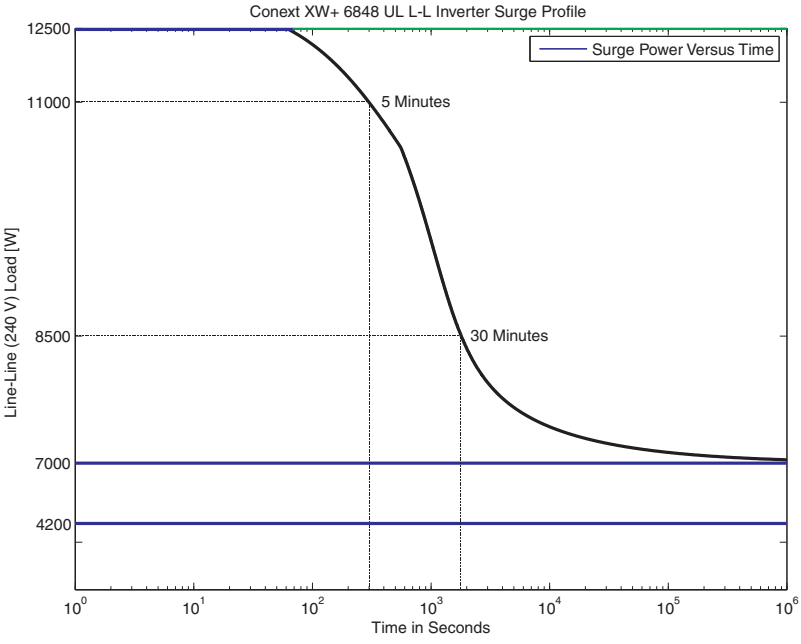
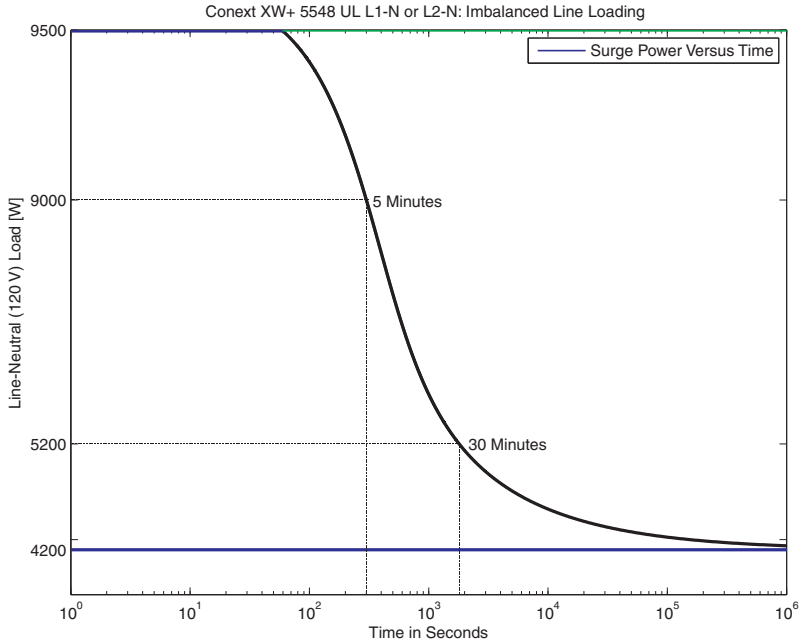

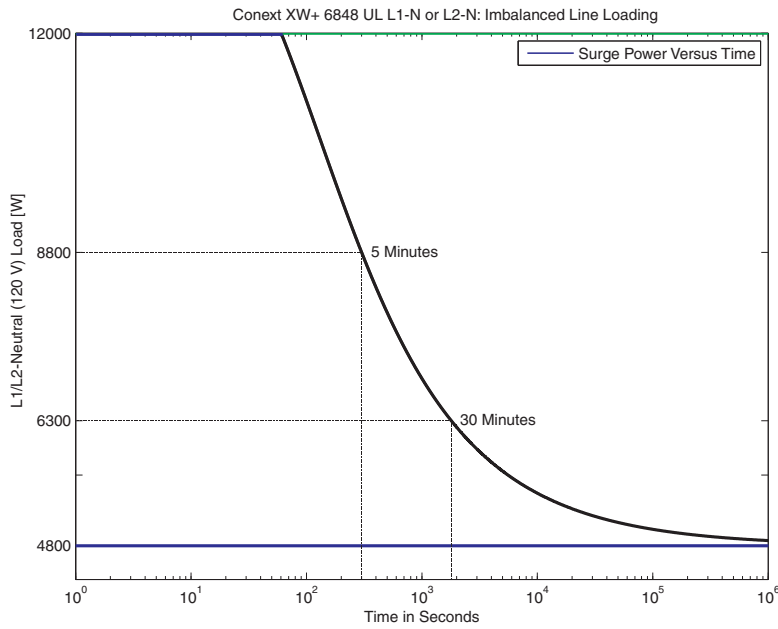

Figure A-1 Conext XW+ AC Overload Capability

Output Power Versus Ambient Temperature

Note: For the Conext XW+ 6848 model, the power can be limited by the installed DC and AC breakers. For example, at 8500 W the DC or AC breakers may disconnect before the 30 minute rating.

When the internal temperature of the Conext XW+ exceeds a preset limit, it begins to limit output power automatically to stop maximum internal temperatures from being exceeded.

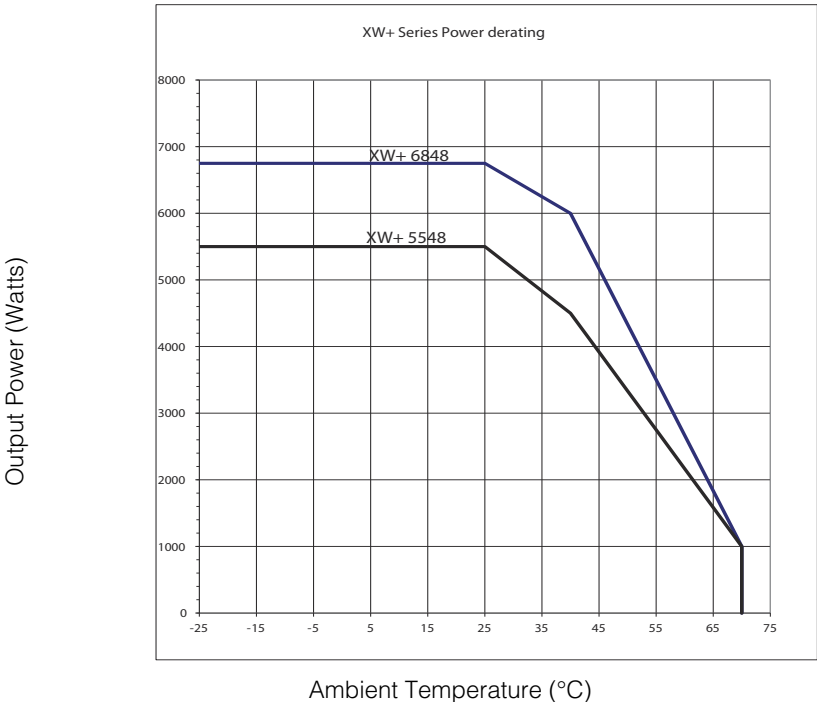

Figure A-2 Output Power Versus Ambient Temperature

Conext XW+ Efficiency

Inverting Efficiency (Typical)

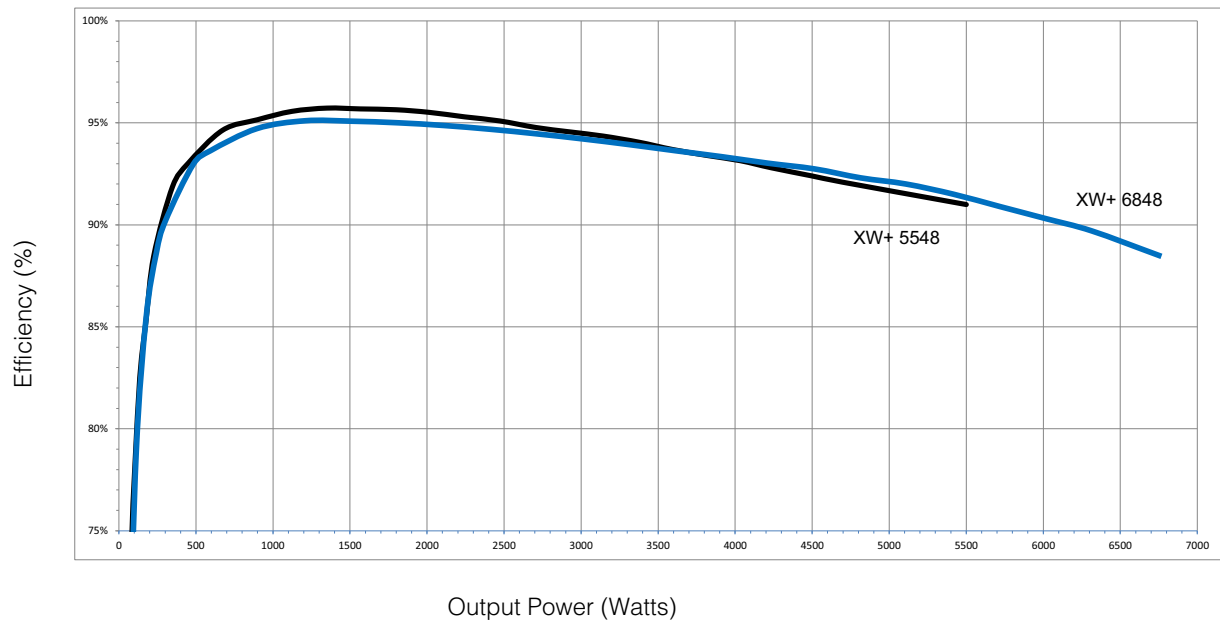

Figure A-3 Inverting Efficiency (Typical)

Charging Efficiency (Typical)

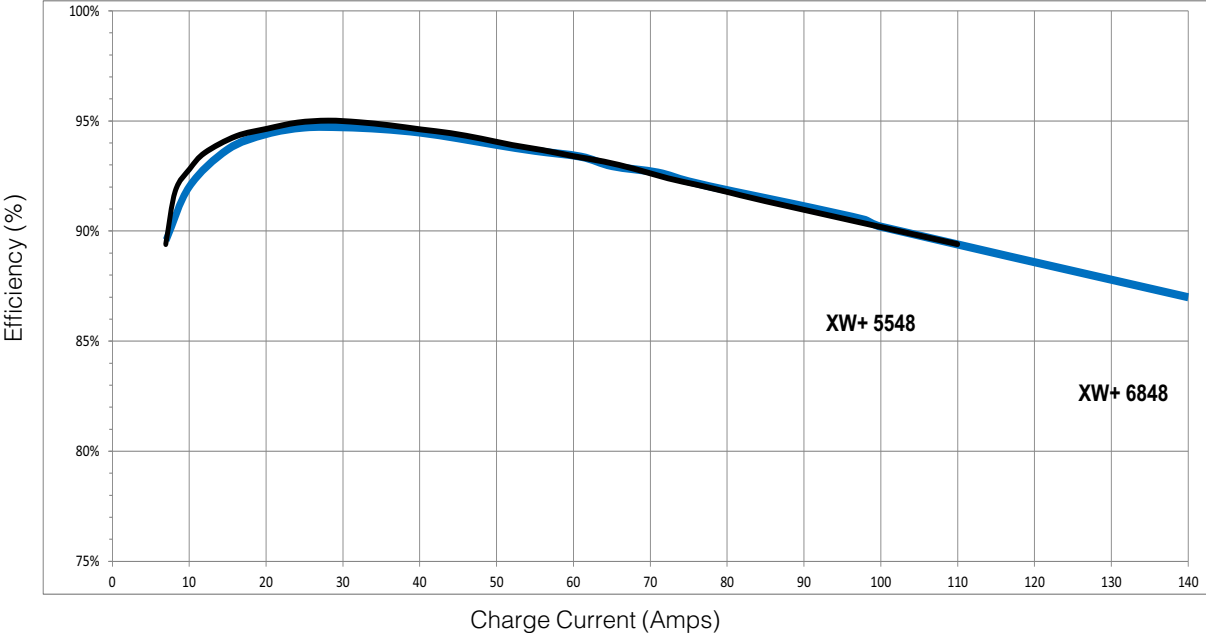

Figure A-4 Charging Efficiency (Typical)

Charging Efficiency Power Factor

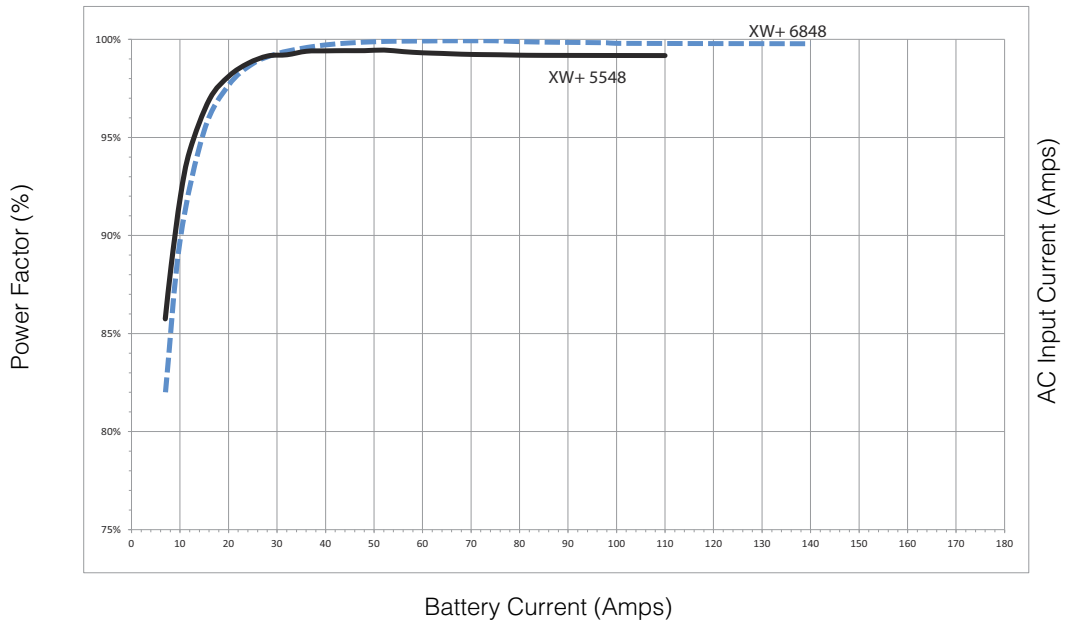

Figure A-5 Charging Efficiency (Power Factor)

Mechanical Specifications

Table A-2 Conext XW+ Inverter/Charger Mechanical Specifications

Model	Conext XW+ 6848 NA	Conext XW+ 5548 NA
Supported Battery Types	Flooded (default), Gel, AGM, Lithium Ion, Custom	
Battery bank size	440–10000 Ah	
Non-Volatile Memory	Yes	
Inverter Information Panel	Status LEDs indicate AC In status, faults/warnings, equalize mode, battery level. 3-character display indicates output power or charge current, fault/warning codes. STARTUP/SHUTDOWN and equalize button	
Multiple Unit Configurations	Clusters of up to 3 parallel units in 120/240 three-wire, single-phase configuration. Up to 4 clusters possible using multi-cluster for a total of 12 units when using an external AC contactor.	
System Network	Conext Xanbus™ (publish-subscribe network, no need for hubs or special cards)	
Emissions	FCC Part 15, Class B Industry Canada ICES-003 Issue 5, Class B	
Regulatory approvals	CSA C22.2 No. 107.1-01 - General Use Power Supplies UL 1741 - 2nd Ed - Inverters, Converters, Controllers and Interconnection System Equipment	
Enclosure Type	NEMA Type 1—Indoor	
Rated Temperature Range (meets specifications)	32–77 °F (0–25 °C)	
Operational Temperature Range	-13–158 °F (-25–70 °C)	
Storage Temperature Range	-40–185 °F (-40–85 °C)	
Inverter Dimensions (H × W × D)	23 × 16 × 9" (580 × 410 × 230 mm)	
Shipping Dimensions (H × W × D)	28 × 22 ½ × 15 ½" (711 × 572 × 394 mm)	
Inverter Weight	125 lb (57 kg)	115 lb (52 kg)
Shipping Weight	132 lb (60 kg)	122 lb (55 kg)

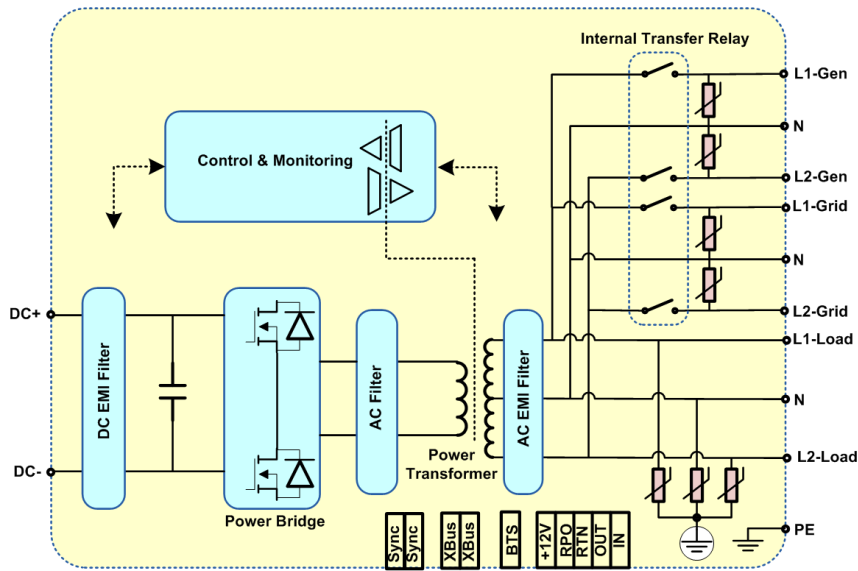

Figure A-6 Conext XW+ Block Diagram

Accessories

Accessory	Part Number
Conext XW+ Power Distribution Panel	865-1015-01
Conext XW+ Power Distribution Panel (Without AC Breakers)	865-1014-01
Conext XW+ Conduit Box	865-1025-01
Conext XW+ Connection Kit	865-1020-02
Conext System Control Panel	865-1050-01
Conext Automatic Generator Start	865-1060-01
Conext MPPT 60 150 Solar Charge Controller	865-1030-1
Conext MPPT 80 600 Solar Charge Controller	865-1032
Conext ComBox	865-1058
Conext Battery Monitor	865-1080-01
Conext XW+ PDP 120/240V 60A Breaker Kit	865-1215-01
Conext XW+ PDP 3-Phase 60A Breaker Kit	865-1315-01

B

Wiring Diagrams

Appendix B, “Wiring Diagrams” illustrate the most basic configurations and are for reference only. Specific installations may require additional equipment to meet national or local electric codes. Ensure all safety requirements are strictly followed.

Single-Inverter System (Backup Only) Without a Conext XW+ Power Distribution Panel

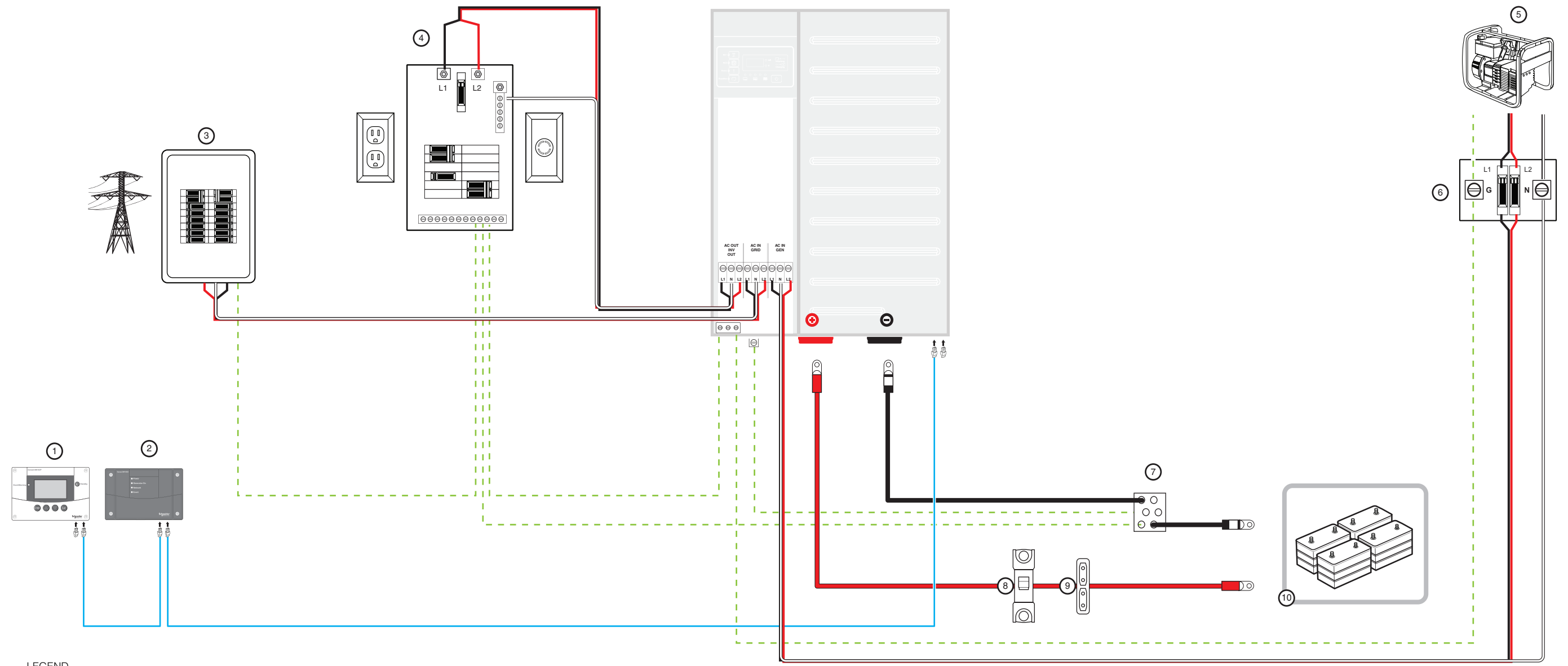

LEGEND

- | | | | | | | | | |
|------------------|---------------------------|------------------------|---------------------------------|-------------------------|---------------|---------|-------------------------------|----------------------------|
| ① SCP (optional) | ③ Main utility panel | ⑤ AC generator | ⑦ Negative ground bus | ⑨ Fuse block (optional) | AC Sync cable | Hot L1 | Positive (+) battery terminal | Positive (+) battery cable |
| ② AGS (optional) | ④ Inverter load sub-panel | ⑥ Generator disconnect | ⑧ Circuit breaker/DC disconnect | ⑩ Battery bank | Xanbus cable | Hot L2 | Negative (-) battery terminal | Negative (-) battery cable |
| | | | | | Ground | Neutral | | |

Actual wiring requirements may vary.
Cable routing may vary.

See Knockout Selection on page 2-5 and Communications Network Preparation on page 2-12.
For torque values, see page 2-16 and 2-17.

For torque connections to the battery terminals, consult the battery manufacturer's recommendations.

Figure B-1 Single-Inverter System (Backup Only) Without a Conext XW+ Power Distribution Panel

Single-Inverter System (Backup Only) With a Conext XW+ Power Distribution Panel

Actual wiring requirements may vary.
 Cable routing may vary.
 See Knockout Selection on page 2-5 and Communications Network Preparation on page 2-12.
 For torque values, see page 2-16 and 2-17.
 For torque connections to the battery terminals, consult the battery manufacturer's recommendations.

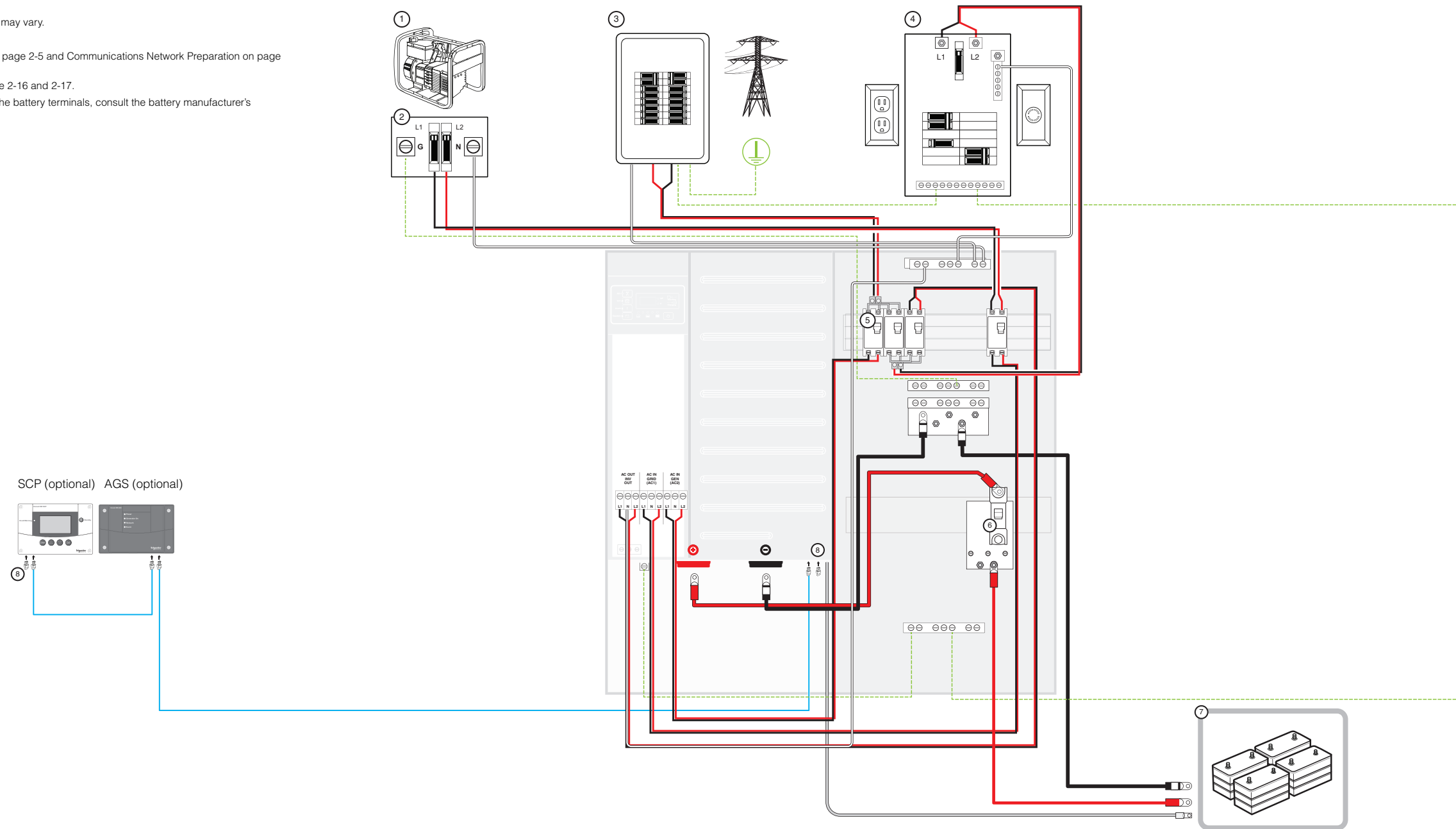

LEGEND

- | | | | | | | | |
|------------------------|---------------------------|-----------------|----------------------|-----------------|-----------|---------------------------------|------------------------------|
| ① AC generator | ③ Main utility panel | ⑤ AC breakers | ⑦ Battery bank | — AC Sync cable | Hot L1 | ⊕ Positive (+) battery terminal | — BTS cable |
| ② Generator disconnect | ④ Inverter load sub-panel | ⑥ DC disconnect | ⑧ Network terminator | — Xanbus cable | Hot L2 | ⊖ Negative (-) battery terminal | — Positive (+) battery cable |
| | | | | - - - Ground | — Neutral | | — Negative (-) battery cable |

Figure B-2 Single-Inverter System (Backup Only) With a Conext XW+ Power Distribution Panel

Single-Inverter System Renewable Energy (Solar)

Actual wiring requirements may vary.
 Cable routing may vary.
 See Knockout Selection on page 2-5 and Communications Network Preparation on page 2-12.
 For torque values, see page 2-16 and 2-17.
 For torque connections to the battery terminals, consult the battery manufacturer's recommendations.

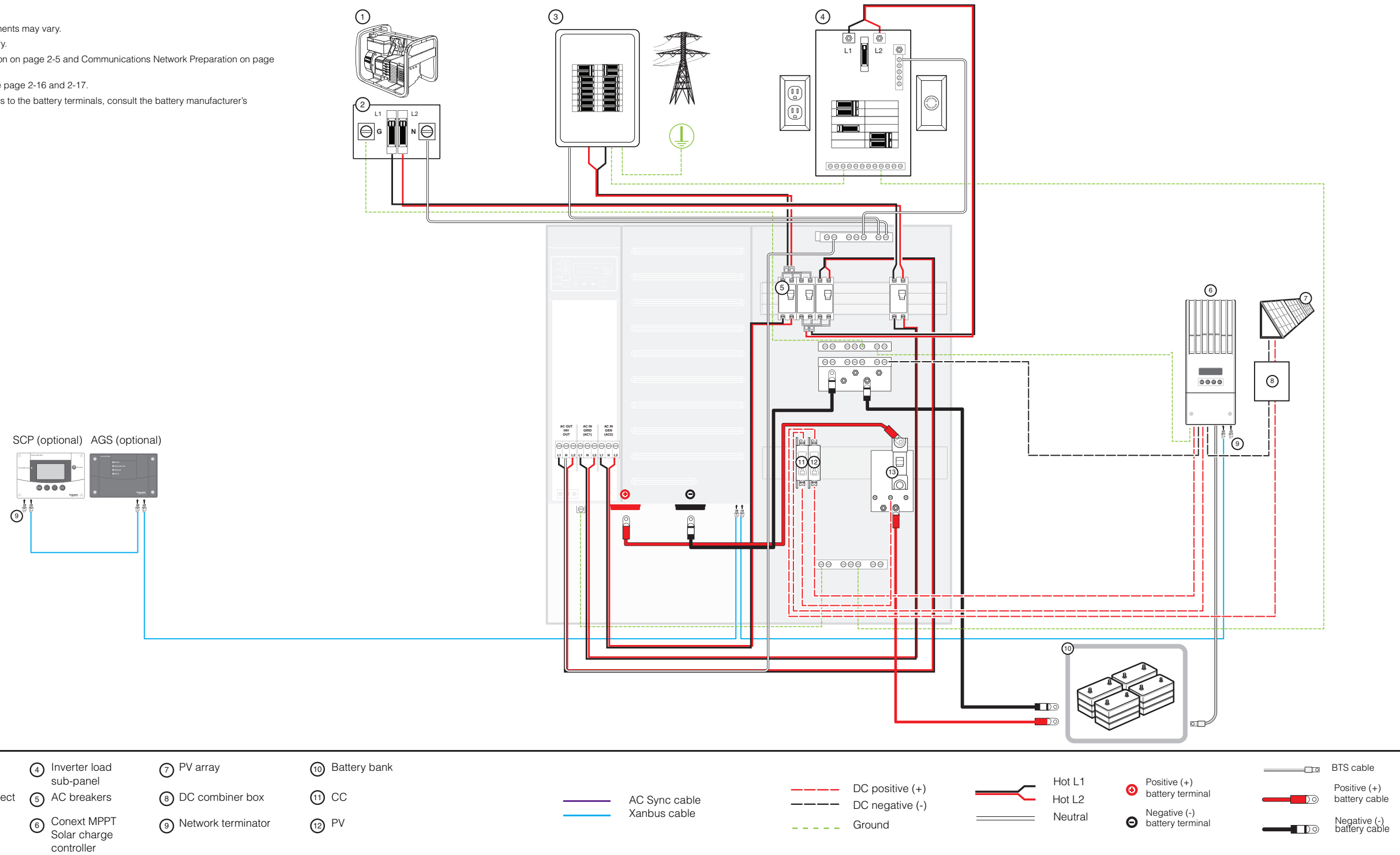

Figure B-3 Single-Inverter System Renewable Energy (Solar)

Dual-Inverter System Renewable Energy (Solar)

Actual wiring requirements may vary.
 Cable routing may vary.
 See Knockout Selection on page 2-5 and Communications Network Preparation on page 2-12.
 For torque values, see page 2-16 and 2-17.
 For torque connections to the battery terminals, consult the battery manufacturer's recommendations.

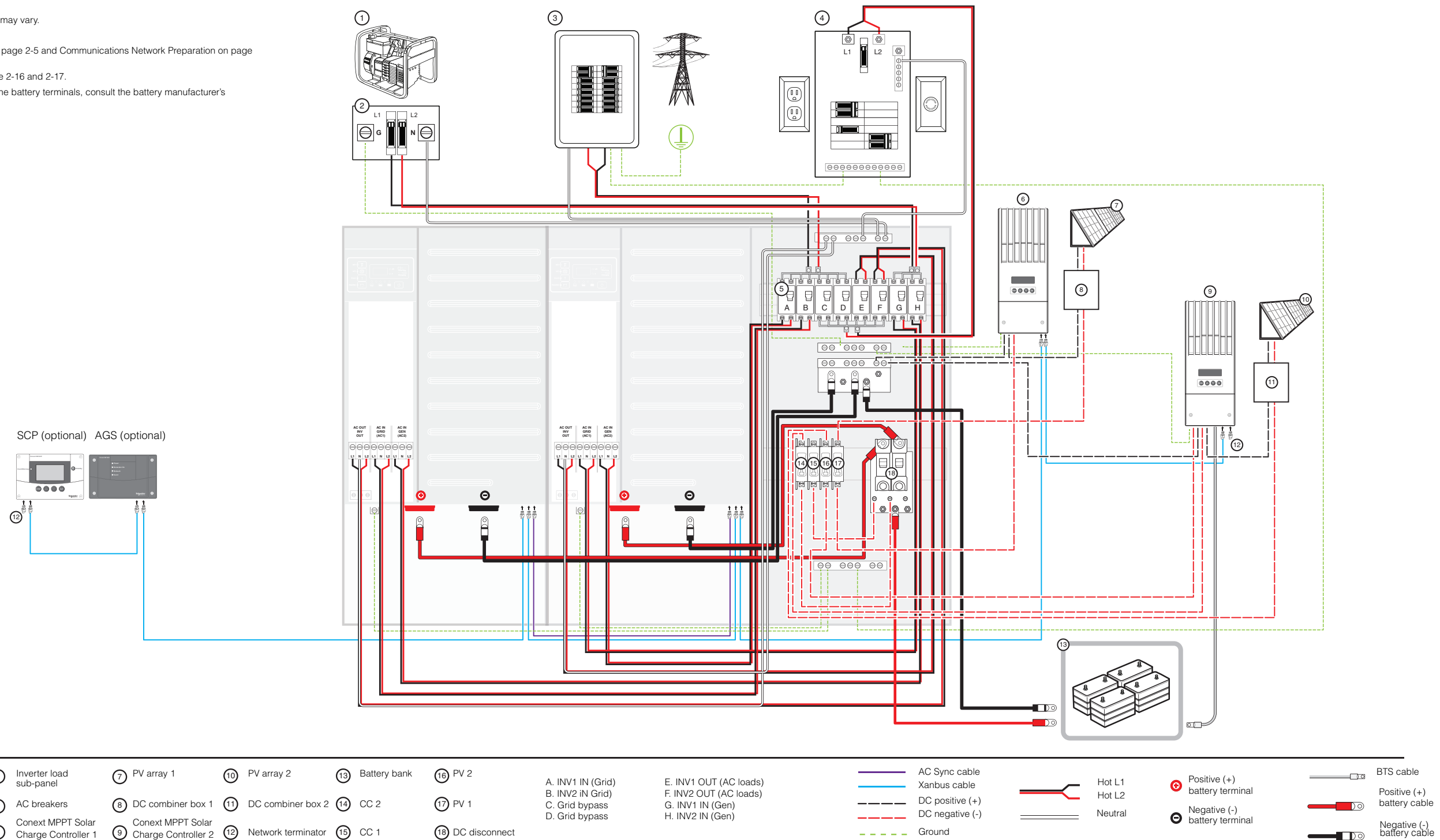

Figure B-4 Dual-Inverter System Renewable Energy (Solar)

C

Split-Phase to Single-Phase Conversion Instructions

Appendix C, “Split-Phase to Single-Phase Conversion Instructions” provides instructions for converting a Conext XW+ Inverter/Charger 120 V/240 V, split-phase model to a 120 V, single-phase model.

Converting 120 V/240 V Split-Phase to 120 V Single-Phase

This chapter explains how to convert a standard 120 V/240 V, three-wire, split-phase Conext XW+ model to accept a 120 V, 2-wire, single-phase connection.

Converting from 120 V/240 V split-phase to 120 V single-phase is required in systems with single-phase (2-wire 120 V) or three-phase (208/120 V) sources. For a three-phase system, the loads may consist of single-phase loads or three-phase loads. Please see “Wiring a Balanced Three-Phase System” on page 3–56.

⚠ DANGER

HAZARD OF ELECTRIC SHOCK, EXPLOSION, OR ARC FLASH

- Apply appropriate personal protective equipment (PPE) and follow safe electrical work practices. See NFPA 70E or CSA Z462.
- This equipment must only be installed and serviced by qualified electrical personnel.
- Never operate energized with covers removed
- Energized from multiple sources. Before removing covers identify all sources, de-energize, lock-out, and tag-out and wait 2 minutes for circuits to discharge
- Always use a properly rated voltage sensing device to confirm all circuits are de-energized.

Failure to follow these instructions will result in death or serious injury.

⚠ DANGER

HAZARD OF ELECTRIC SHOCK, EXPLOSION, OR ARC FLASH

- Remove watches, rings, or other metal objects.
- This equipment must only be installed and serviced by qualified electrical personnel.
- Keep sparks and flames away from the batteries.
- Use tools with insulated handles.
- Wear protective glasses, gloves and boots.
- Do not lay tools or other metal parts on top of batteries.

Failure to follow these instructions will result in death or serious injury.

▲ DANGER

HAZARD OF ELECTRIC SHOCK, EXPLOSION, OR ARC FLASH

- Battery Circuit Breakers must be installed according to the specifications and requirements defined by Schneider Electric.
- Servicing of batteries must only be performed by qualified personnel knowledgeable of batteries and the required precautions. Keep unqualified personnel away from batteries.
- Disconnect the charging source prior to connecting or disconnecting battery terminals.

Failure to follow these instructions will result in death or serious injury.

Contact Customer Service for further assistance. Please be prepared to describe details of your system installation and provide the model and serial number of the unit. See page ii for contact information.

Note: To complete the conversion, you must refer to instructions in the *Conext Configuration Tool User's Guide* (Document Part Number 975-0365-01-01) available from **www.SEsolar.com**.

Note: To set up a three-phase system using three 120 V-configured Conext XW+ units, perform the conversion procedure for all three Conext XW+ Inverter/Chargers.

Installation Tools and Materials

To complete the conversion, you will need the following:

- a Phillips #2 screwdriver
- one small jumper and three large jumpers, included with the Conext XW+ Inverter/Charger (See Figure C-1.)

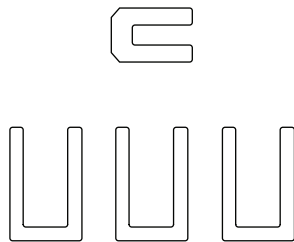

Figure C-1 Conext XW Jumpers

Disconnecting Power Sources

To disconnect power sources:

1. Put the Conext XW+ system in Standby mode using the System Settings menu on the Conext System Control Panel, disconnect AC sources (such as the utility grid and generators) by turning off the AC input breakers, and disconnect DC sources (for example, batteries) by turning off the DC breaker.
2. Turn off and disconnect all AC loads by turning off the AC output breaker.

AC Access Panel Removal

⚠ DANGER

HAZARD OF ELECTRIC SHOCK, EXPLOSION, OR ARC FLASH

- Apply appropriate personal protective equipment (PPE) and follow safe electrical work practices. See NFPA 70E or CSA Z462.
- This equipment must only be installed and serviced by qualified electrical personnel.
- Never operate energized with covers removed
- Energized from multiple sources. Before removing covers identify all sources, de-energize, lock-out, and tag-out and wait 2 minutes for circuits to discharge
- Always use a properly rated voltage sensing device to confirm all circuits are de-energized.

Failure to follow these instructions will result in death or serious injury.

⚠ DANGER

HAZARD OF ELECTRIC SHOCK, EXPLOSION, OR ARC FLASH

- Remove watches, rings, or other metal objects.
- This equipment must only be installed and serviced by qualified electrical personnel.
- Keep sparks and flames away from the batteries.
- Use tools with insulated handles.
- Wear protective glasses, gloves and boots.
- Do not lay tools or other metal parts on top of batteries.

Failure to follow these instructions will result in death or serious injury.

⚠ DANGER

HAZARD OF ELECTRIC SHOCK, EXPLOSION, OR ARC FLASH

- Battery Circuit Breakers must be installed according to the specifications and requirements defined by Schneider Electric.
- Servicing of batteries must only be performed by qualified personnel knowledgeable of batteries and the required precautions. Keep unqualified personnel away from batteries.
- Disconnect the charging source prior to connecting or disconnecting battery terminals.

Failure to follow these instructions will result in death or serious injury.

To remove the AC access panel, remove the two screws from the AC access cover and slide the cover slightly to the left and lift away from the Conext XW+ chassis.

Installation tip

For easier access, first remove the right-side panel of the Conext XW+, as shown in Figure 5-3 on page 5–6.

When re-securing the AC access cover, ensure its recessed edge slips inside the edge of the front panel.

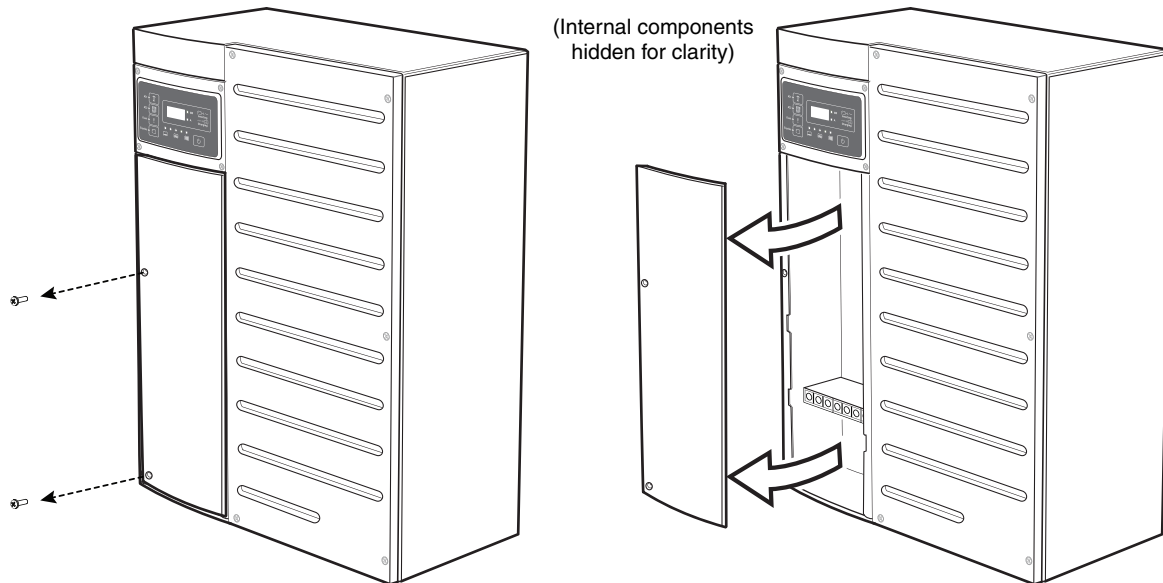

Figure C-2 AC access panel removal

Reconfiguring the Secondary Transformer Wires on X1 and X2 Connectors

To reconfigure the secondary transformer wires on the X1 and X2 connectors:

1. Locate the X1 and X2 connectors (see Figure C-3).

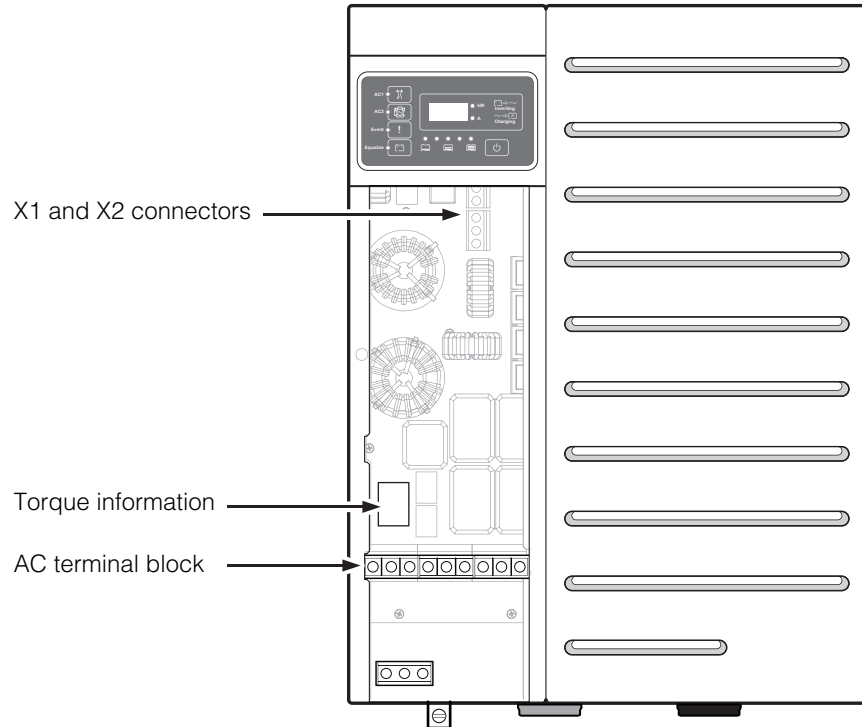

Figure C-3 Connector Locations.

2. Remove the secondary transformer wire X2 (black) from slot X2-A, and then insert it into slot X2-B (see Figure C-4 and Figure C-5).
3. Remove the secondary transformer wire X3 (white) from slot X3-A, and then insert it into slot X3-B (see Figure C-4 and Figure C-5).
4. Insert one small jumper between slot X2-A and X2-B (see Figure C-4 and Figure C-5). Insert jumper on top of the wire.
5. Tighten all terminals to 35 in-lb (4.0 N-m) per the torque information printed on the AC board. See Figure C-3 for the torque information location.

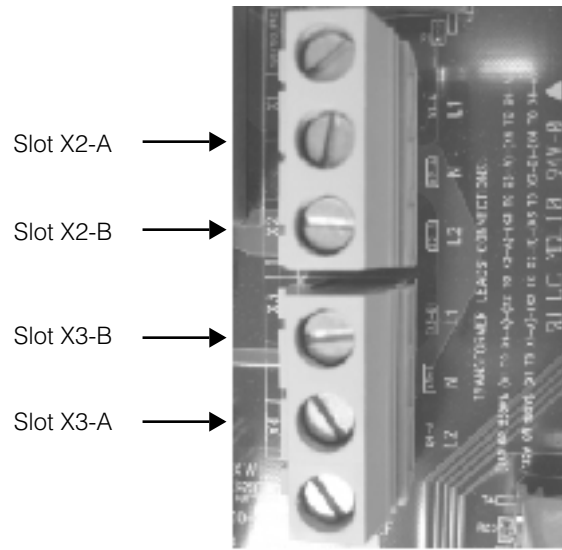
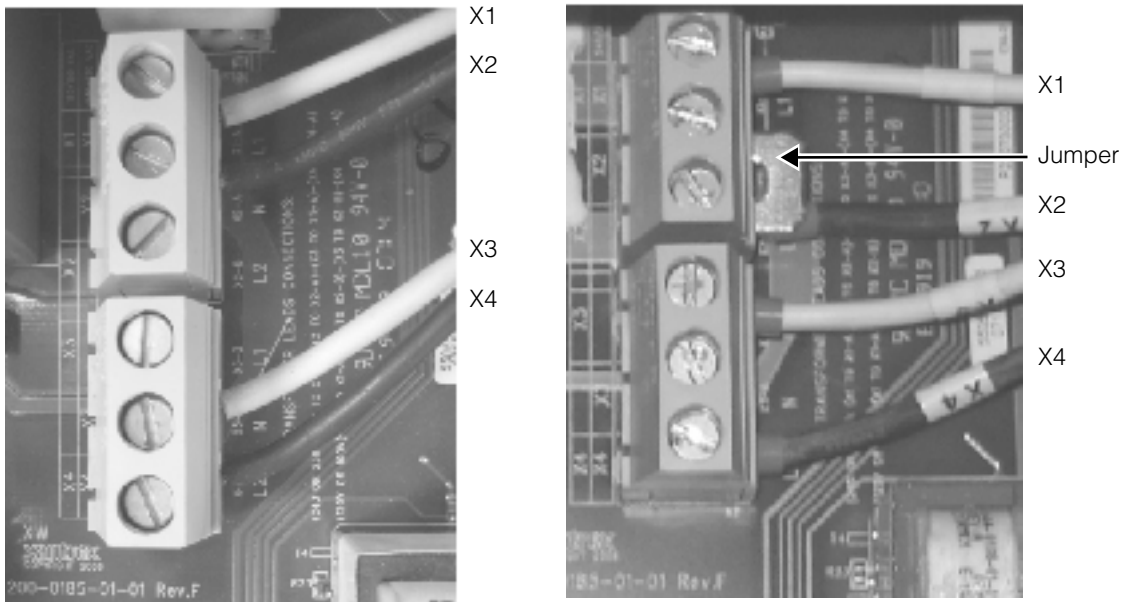

Figure C-4 Slot Locations on X1 and X2 Connectors



Secondary transformer wire X1, X2, X3, and X4 locations BEFORE reconfiguration

Secondary transformer wire X1, X2, X3, and X4 locations AFTER reconfiguration

Figure C-5 X1 and X2 Connectors Before and After Reconfiguration

Reconfiguring the AC Ports on the Load, AC1, and AC2 Connectors

To reconfigure the AC ports on the Load, AC1 (Grid), and AC2 (Gen) connectors:

1. Locate the Load, AC1 (Grid), and AC2 (Gen) connectors (see Figure C-3 on page C-7).
2. Insert one large jumper in each connector to short out N and L2, as shown in Figure C-6.

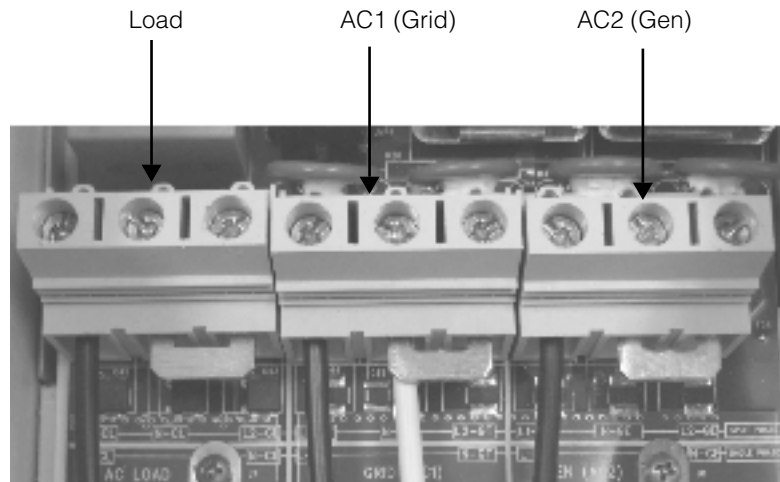

Figure C-6 Jumper Locations and AC Cable Configuration on AC Ports

3. Connect the AC cables as shown in Figure C-6. Insert jumper on top of the wire.
4. Tighten all terminals per the torque information printed on the AC board. See Figure C-3 on page C-7 for the torque information location.
5. Reconnect the DC sources (for example, batteries) by turning on the DC breaker.

Upgrading the Firmware

To upgrade the firmware, refer to instructions in the *Conext Configuration Tool User's Guide* (Document Part Number 975-0365-01-01). If you do not have this guide, download it from **www.SEsolar.com**.

You will also need to connect the Conext XW+ Inverter/Charger to your computer using a USB-to-Xanbus adapter (Product Part Number 865-1155).

To upgrade the firmware:

1. Download the USB-to-Xanbus adapter driver (available on **www.SEsolar.com**).
2. Connect the USB-to-Xanbus adapter to a USB port on your computer, and then install the downloaded driver. See the *Conext Configuration Tool User's Guide* for detailed instructions.
3. Download the latest firmware for your Conext XW+ Inverter/Charger from **www.SEsolar.com** and save it onto your computer.
4. Make sure nominal DC voltage is present at the unit's DC terminals.
5. Download the latest Conext Configuration Tool software from **www.SEsolar.com** and install it onto your computer.
6. Run the Conext Configuration Tool.
7. Select **Firmware > Convert Phase** from the **Tools** menu and follow the on-screen instruction to complete the conversion.

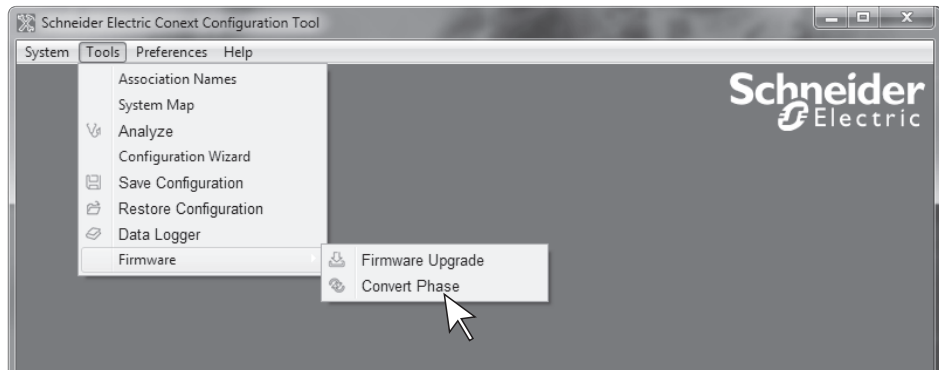

Figure C-7 Upgrading the firmware

8. Record the new firmware version for future reference.

Updating the Label

On the inverter/charger, mark the box on the bottom of the label beside “OPTIONAL CONFIGURATION, 120 v, 2 WIRE” to indicate the inverter has been converted. See Figure C-8.



Figure C-8 Updated Label

Schneider Electric

www.SEsolar.com

For other country details please contact your local Schneider Electric Sales Representative or visit our website at:
<http://www.schneider-electric.com/sites/corporate/en/support/operations/local-operations/local-operations.page>