



WEEB Clip



Ground Lug

Wholesale Solar's Comprehensive Guide: IronRidge Rails with the Wiley WEEB Ground System including optional QuickMount Flashings



- QuickMount
- WEEB Grounding
- XRS Rail Mounting.

RACKING LAYOUT OPTIONS

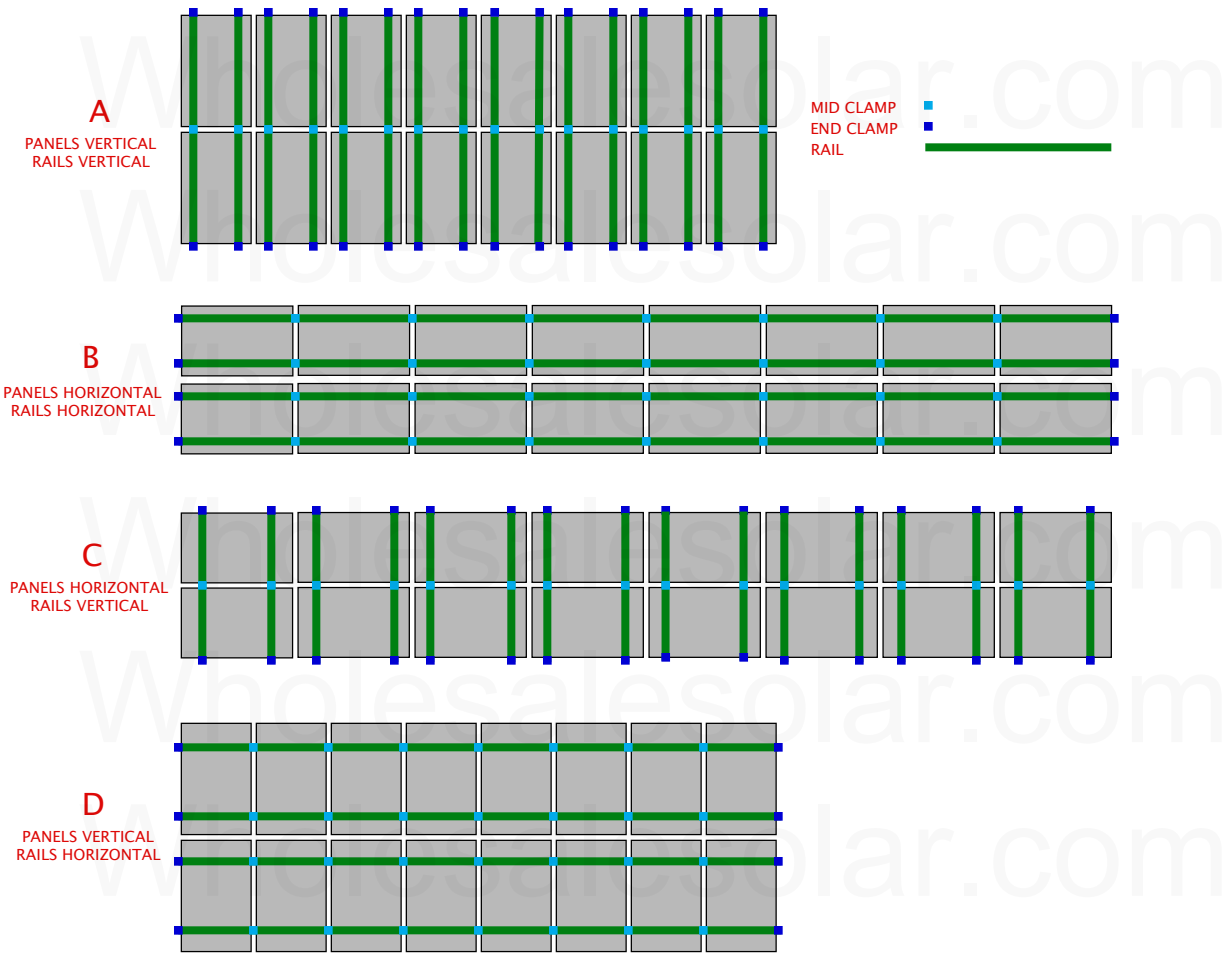

Wholesale Solar, Inc.
412 N. Mount Shasta Blvd
Mount Shasta CA 96067
Toll Free 800-472-1142
Fax 530-926-1162
www.wholesalesolar.com

Quick Mount PV[®]

Your *Solution* in Mounting Products

Solar • H₂O • Conduit • HVAC • Custom

Composition Mount Specifications

Quick Mount PV[®] is an all-in-one waterproof flashing and mount to anchor photovoltaic racking systems, solar thermal panels, air conditioning units, satellite dishes, or anything you may need to secure to a new or existing roof. It is made in the USA of all aluminum and includes stainless steel hardware. It works with all standard racks, installs seamlessly and saves labor by not needing to cut away any roofing, will out live galvanized 2 to 1, and is a better low-profile mount.

Flat Washer 1" x 5/16"

EPDM Rubber Washer 60 Durometer

Sealing Washer 3/4" x 5/16"

Hanger Bolt 5/16" x 6"

1-1/2" Machine, 1-1/2" Spacer, 3" Lag

Mount & Flashing Aluminum

Mount 2-1/4"l x 1-1/4"w x 1-1/4"h

Flashing .05" thick

For standard composition roofs: flashing is

12" x 12", mount is attached 3" off center

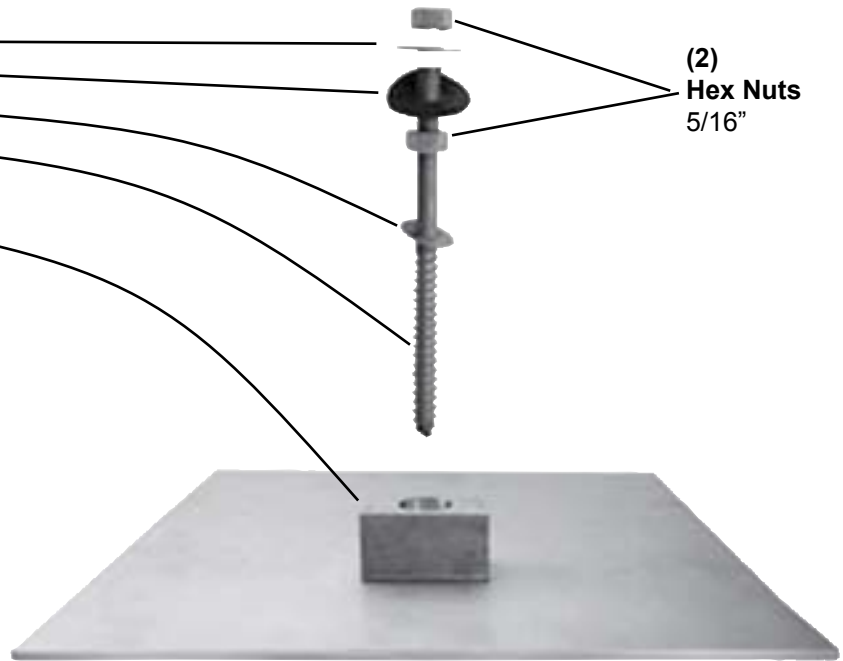

Lag pull-out (withdrawal) capacities (lbs) in typical lumber:

	Specific gravity	Lag Bolt Specifications	
		5/16" shaft per 3" thread depth	5/16" shaft per 1" thread depth
Douglas Fir, Larch	.50	798	266
Douglas Fir, South	.46	705	235
Engelmann Spruce, Lodgepole Pine (MSR 1650 f & higher)	.46	705	235
Hem, Fir	.43	636	212
Hem, Fir. (North)	.46	705	235
Southern Pine	.55	921	307
Spruce, Pine, Fir	.42	615	205
Spruce, Pine, Fir (E of 2 million psi and higher grades of MSR and MEL)	..50	798	266

Sources: Uniform Building Code; American Wood Council

Notes: 1) Thread must be embedded in a rafter or other structural roof member.

2) Pull-out values incorporate a 1.6 safety factor recommended by the American Wood Council.

3) See IBC for required edge distances.

936 Detroit Ave Suite D, Concord, CA. 94518
 Phone: (925) 687-6686 Fax: (925) 687-6689
 Email: info@quickmountpv.com www.quickmountpv.com

Know Your Roof

It is a good idea to do a thorough roof evaluation prior to your project installation. At this time you should do a layout on the roof confirming everything on the drawing will fit as it is intended. Any irregularities should be noted now, so that you can deal with them simply on install day. The quality of the roofing should be determined, so that any repairs or replacement can happen before or in conjunction with the installation. On a composition roof it is important to know as much as possible about: the manufacturer, the age of roof, the type of substrate (plywood or oriented strand board [OSB]), the rafter size, the spacing and span, the age of roof structure, who roofed it, who built it, etc.

Photos should be taken of all of the roof variables and associated with the job file for any future reference either short term or long. Typically the building owner can look in a file and find the composition manufacturer. If not, take a piece to the roofing yard, they can usually recognize the maker and the rough vintage. It is then easy to obtain the written manufacturer's installation instructions for the roofing materials you are dealing with. The manufacturer's instructions will spell out exactly what does and does not void the warranty of their roofing product. Most have a clause about roof temperature. This is commonly missed, but can easily be noted if you read the instructions. Officially, the roofing manufacturer's instructions supersede our instructions, as our product is weaving into theirs. It is also important to have their instructions in the job file, for any future reference. If the manufacturer cannot be found, there is obviously no warranty in place.

On a roof that has a material and labor warranty in place (new roof), it is recommended to at least consult the roofer of record. Often the roofing contractor will void the labor portion of their warranty if another trade modifies their work. Give the roofing contractor the option of handling the roofing modifications, or at least give them the opportunity to inspect and approve the modifications you make. There will be fees to this roofer, but if it maintains the labor warranty it should be good money spent.

Product Selection

The Composition Mount is intended to fit within most composition and wood shingle roof systems, but not all. Specifically it is sized to fit within a standard 5" to 5 1/2" row or course. To confirm that the Comp Mount will match your roof, measure the course exposure of your roof. The "exposed" surface course height should measure no more than 5 3/4". If it turns out the roof tiles are a non-standard size greater than 5 3/4", the alternative method is to use a Quick Mount Shake Mount instead. In this case, follow the directions for the Quick Mount Shake Mount. (See Composition Mount Instructional Video at quickmountpv.com/tech.php, then Shake Composition Video:

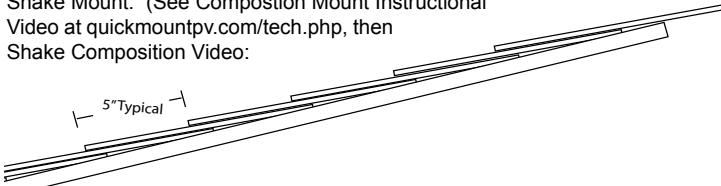

High Definition Comp - Presidential

Irregular surface - If the penetration lands in a low between two highs, it is best to shim the low under the flashing with extra asphalt to level out the surface.

Irregular tooth pattern - If the shingles have a tooth pattern wherein the bottom edge jogs up and down to give it a higher profile look, it is important to understand that the excess shingle that hangs lower than the rest of the shingle is for looks only. The 5" rule starts at the top of the tooth. If a tooth interferes with the mount block, cut the tooth off.

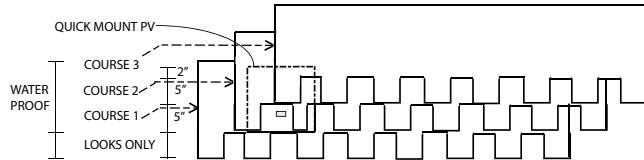

How Many Mounts Per Module?

There are two questions that must be asked when adding anything to a roof.

1. Can the roof / building / foundation handle the additional load?
2. What is to keep the new load from blowing away?

It is assumed that a licensed solar installer can answer these questions. If he / she can't, he / she will need to find somebody that can. A licensed engineer is the easiest solution. Some of the racking manufacturers have guides to calculating a code compliant install as well. Many variables must be considered and determined to complete the calculation. The spacing between mounts has the variables of: strength of rail, distance between parallel rails, cantilever of modules over rails, pull out strength of mount, slope of roof, height of roof, wind zone, roof type, structural integrity of roof framing, etc. The only values in the variables above that we can provide is pull out strength and shear of mount. We provide structural test reports on all of our mounts as needed. You will need to do the calculation of variables as you are the only one who knows them all.

Further Resources

In the process of all the research we have done, we came up with what we call the "Wheel of Accountability". It is a graphical look at the many official entities that govern how waterproofing should be done. At our web site you can click on any wedge of the wheel and get the code snippets that pertain to that entity's focus on roof penetrations.

Please don't hesitate to use it to your advantage. And of course if you have any feed back pro or con, let us have it. Take photos of your jobs using Quick Mount Products and submit them to us at info@quickmountpv.com, we'll put them up in our web gallery. Put Photo Gallery in the Subject line.

Product Includes

The units are sold in 12 packs. Each 12 pack includes the mounting hardware and the mount with flashing to install 12 mounts, with written instructions.

Alternative Attachment Methods

The Composition Mount is intended to be attached into a lumber rafter. Mounts are usually laid out based on the location of the rafters. In some cases it is desired to place a mount where there is no rafter. In this case it is possible to place a block between rafters, then lag into the block. In the case of metal rafters, lumber blocking the rafters is a solution, but should be done per the building's engineer of record.

Shared Rail & 5" Rule

On a shared rail system, where the mounts must be in an exact spot, it is important to make sure the unit is flashed properly. Normally the vertical placement is guided by the exposed front edge of the shingle. If (on a 5" exposure comp) the flashing is flush with this, then you have 5" of flashing over course 1, 5" of flashing under course 2, and 2" of flashing under courses 2 and 3. This is important because if there is a vertical joint in course 2 the water cannot find its way under the flashing because it extends under course 3. When the flashing must be shifted to catch a shared rail, it is advised to shift the mount up the roof only, leaving less flashing over course 1, and more flashing under course 3. If it is necessary to shift downward, it is advised to move down a whole course and then shift up accordingly.

Sealants

It is important to put a compatible sealant into any and all holes drilled into a roof. We have been recommending Geocell 2300, but there are many that are compatible with: asphalt, wood, aluminum, and stainless steel. In the freeze-thaw zones, it is important to follow the manufacturers' rules for freeze-thaw conditions.

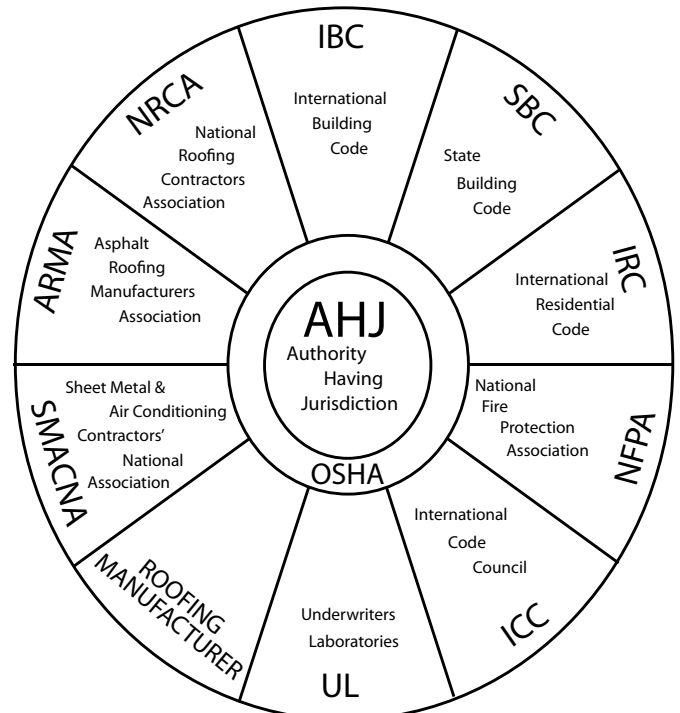

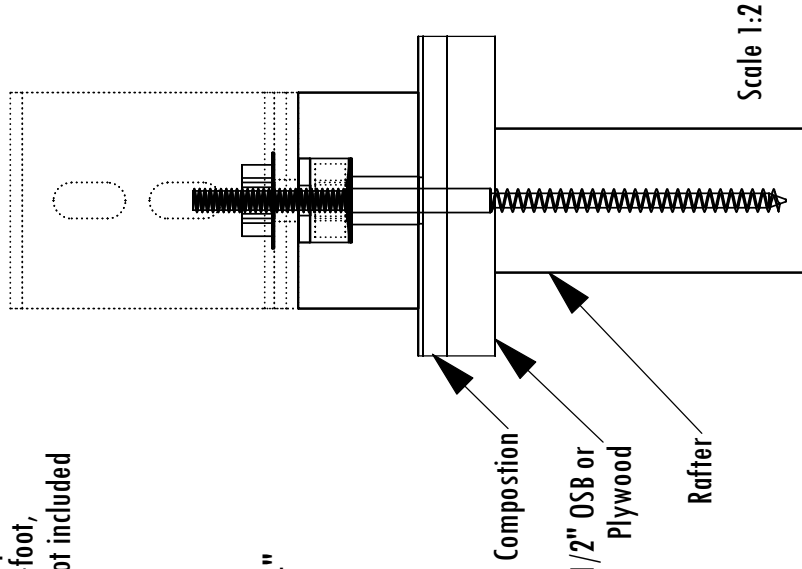
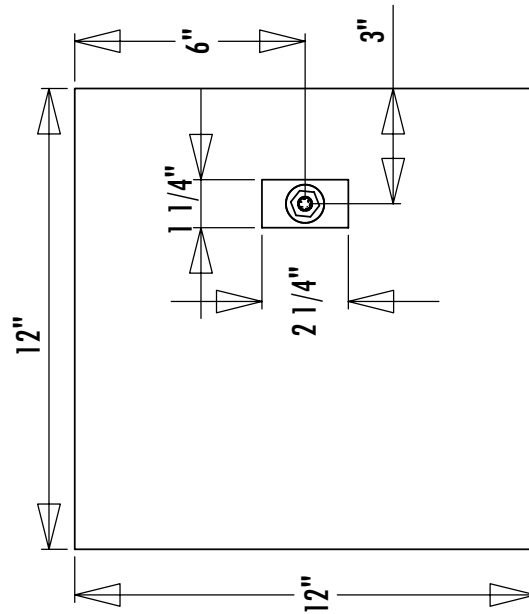
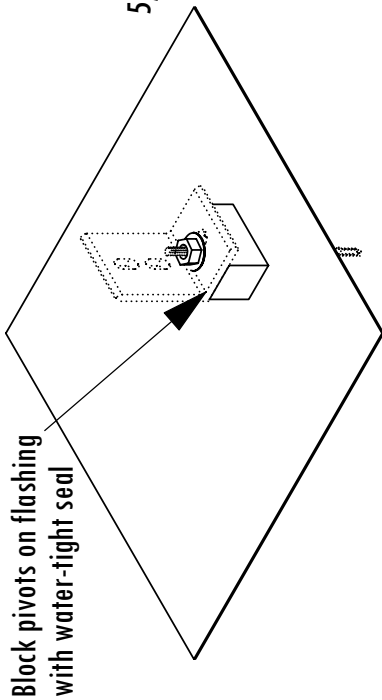
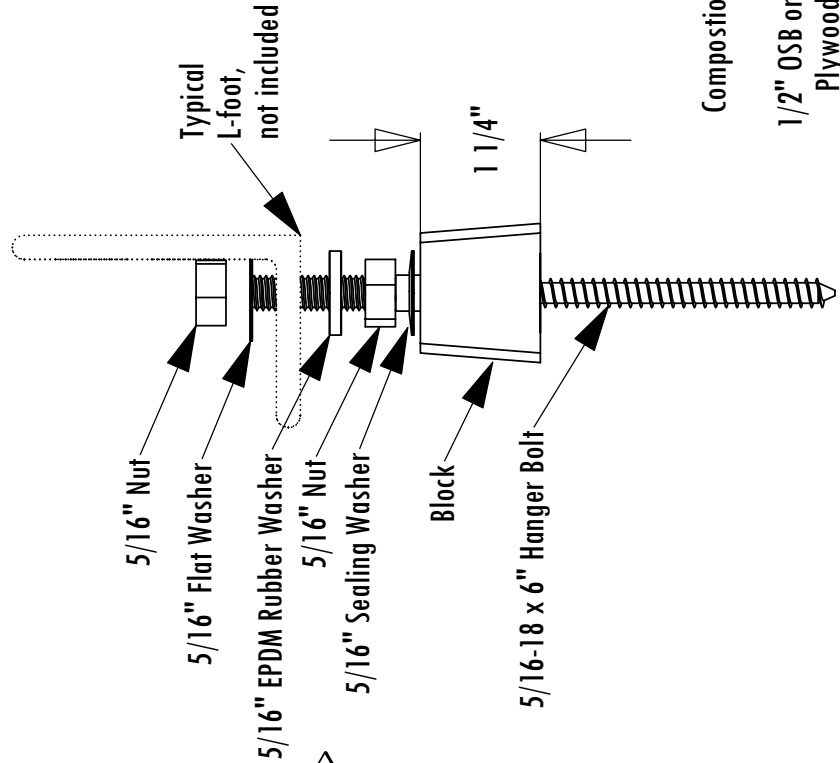

TITLE: QM-PV-Comp - 5/16"

COMMENTS

DATE 8/08/08

REVISION 2

DRAWN BY A.B.K.

FILE NAME QMSC3125_EXP

Scale 1:5

Quick Mount PV
 Your Solution in Mounting Products
 Solar • H₂O • Conduit • HVAC • Custom

Quick Mount PV[®]

COMPOSITION MOUNTING INSTRUCTIONS 5/16"

Installation Tools Required: Tape Measure, Roofers Bar / Shingle Ripper, Chalk Line, Stud Finder, Caulking Gun, 1 Tube of Appropriate Sealant, Drill with 1/4" long bit, Drill or Impact Gun with 1/2" Deep Socket.



1 Locate, choose, and mark centers of rafters to be mounted. Select each row course of roofing for Mount placement of Quick Mounts.



2 Lift Composition roof shingle with Roofers Bar, just above placement of Quick Mount.



3 Slide Mount into desired position. Remove any nails that conflict with getting Mount flush with front edge of shingle course. Mark center for drilling.



4 Using drill with 1/4" long bit, drill pilot hole into roof and rafter, taking care to drill square to the roof.



5 Clean off any saw dust, and fill hole with Sealant.



6 Slide Mount back into position. Prepare Hanger Bolt with 1 Hex Nut and 1 Sealing Washer, insert through Block into hole and drive Hanger until Block is tight.



7 Insert EPDM Rubber Washer over Hanger Bolt into Block.



8 Using the Racking Hardware, secure the rack of your choice. Tighten to 16 foot pounds.

You are now ready for the rack of your choice. Follow all the directions of the rack manufacturer as well as the module manufacturer.

All roofing manufacturers' written instructions must also be followed by anyone modifying a roof system. Please consult the roof manufacturers' specs and instructions prior to touching the roof.

Wiley Electronics LLC

Washer, Electrical Equipment Bond

WEEB

Patent Pending

INSTALLATION INSTRUCTIONS

For IronRidge

Please read carefully before installing.



WEEB-DMC

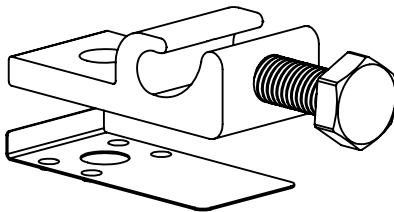

WEEBL-6.7

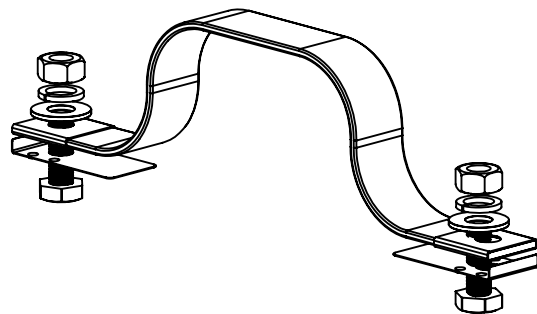

WEEB Bonding Jumper-6.7



Intertek
3098177

Products are tested to UL 467
UL standard for safety grounding and bonding equipment

Document Number 104-0404-000039-000

WEEB COMPATIBILITY

The WEEB family of products can be used to bond anodized aluminum, galvanized steel, steel and other electrically conductive metal structures.

Standard Top Down Clamps

The WEEBs used for bonding the PV modules to the mounting rails are compatible with various cross-sections of module frames. The following are examples of module frames that are compatible. Notice that the WEEB teeth are positioned completely under the edge of the module frame.

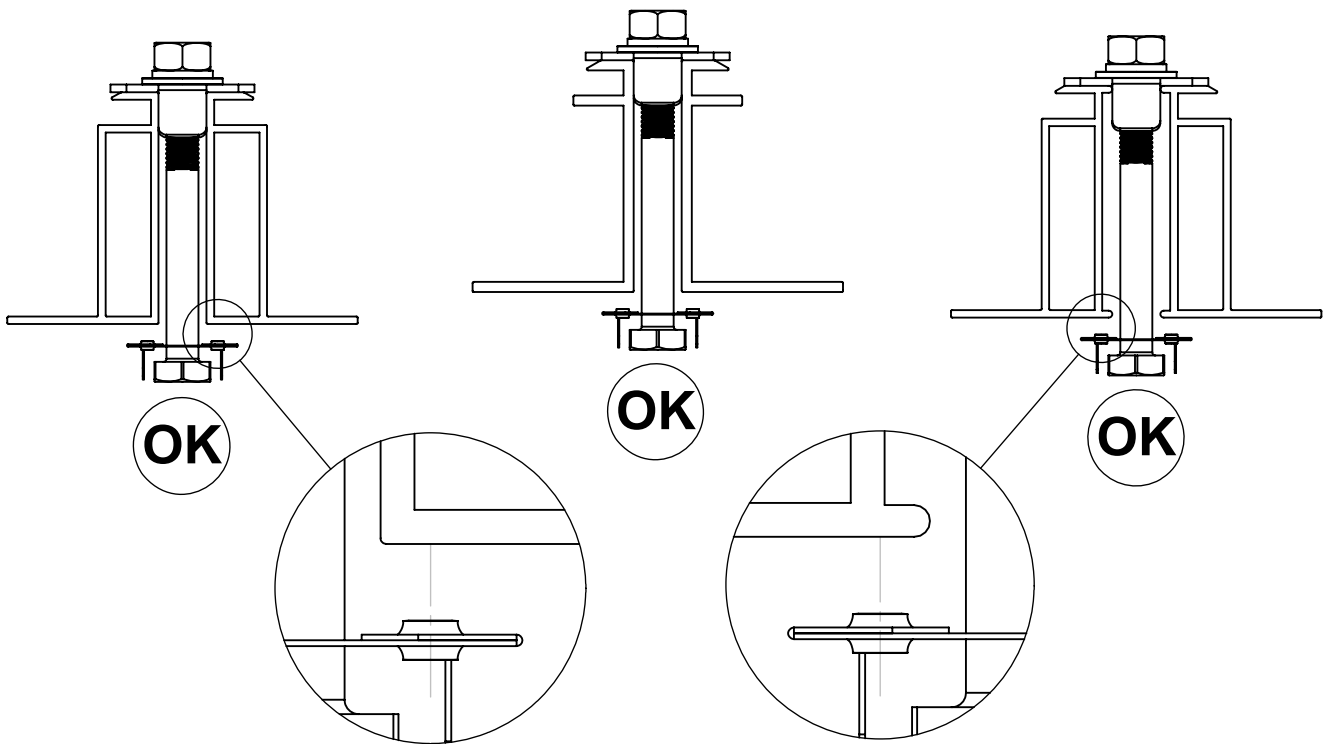

The following is an example of a module frame that is incompatible with the WEEB. The WEEB teeth are positioned only partially under the edge of the module due to the lip on the top edge of the module frame.

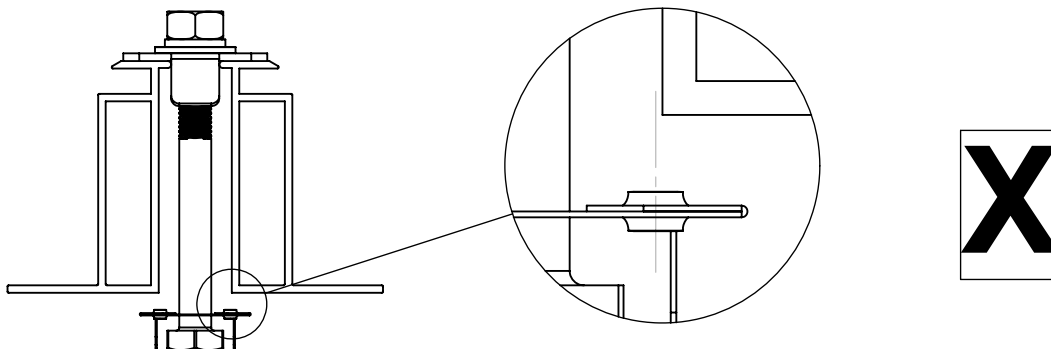

Top Down Clamps for Lipped Modules

The following are a few variations of lipped solar modules mounted with inverted U-shaped clamps. Notice that the force which the inverted U-shaped clamp exerts is in line with the WEEB teeth.

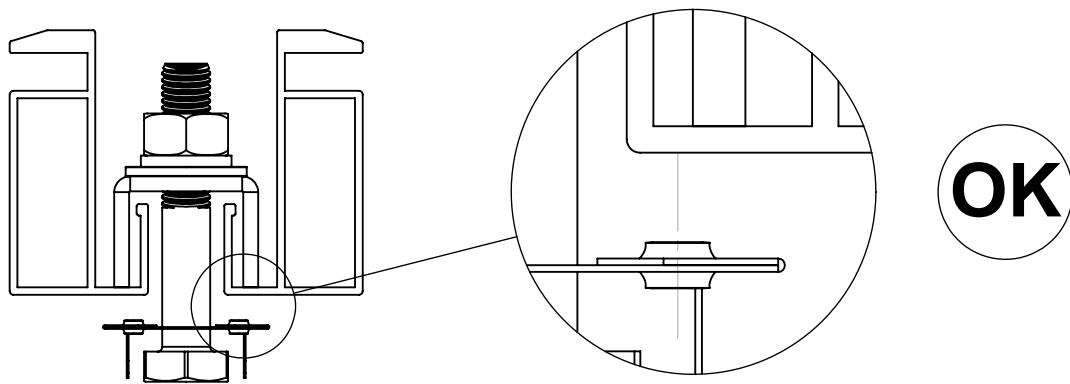

Low-Lipped Module

WEEB-DMC is not compatible with high lipped modules. The WEEB teeth do not intersect with the solar module frame.

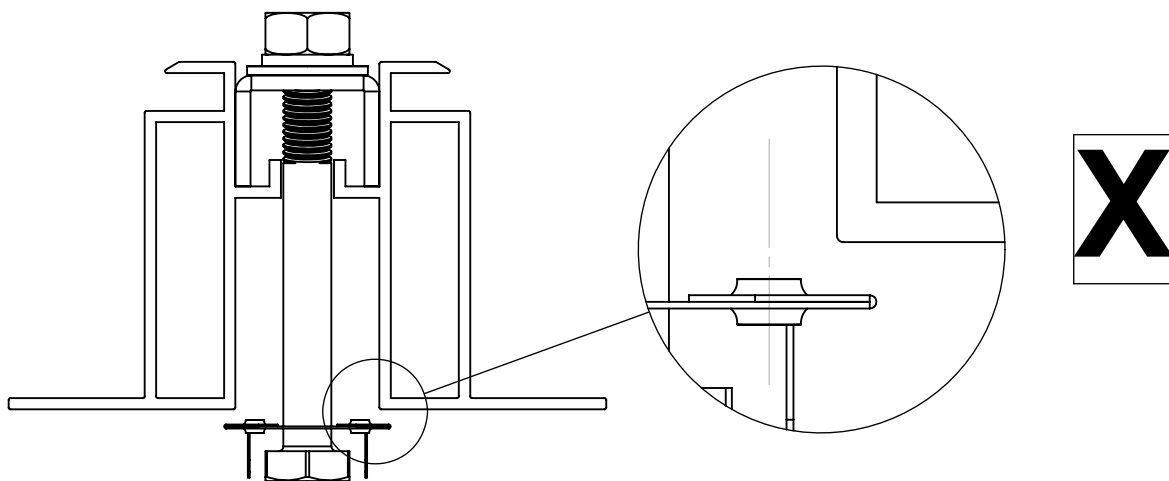

High-Lipped Module

SYSTEM OVERVIEW

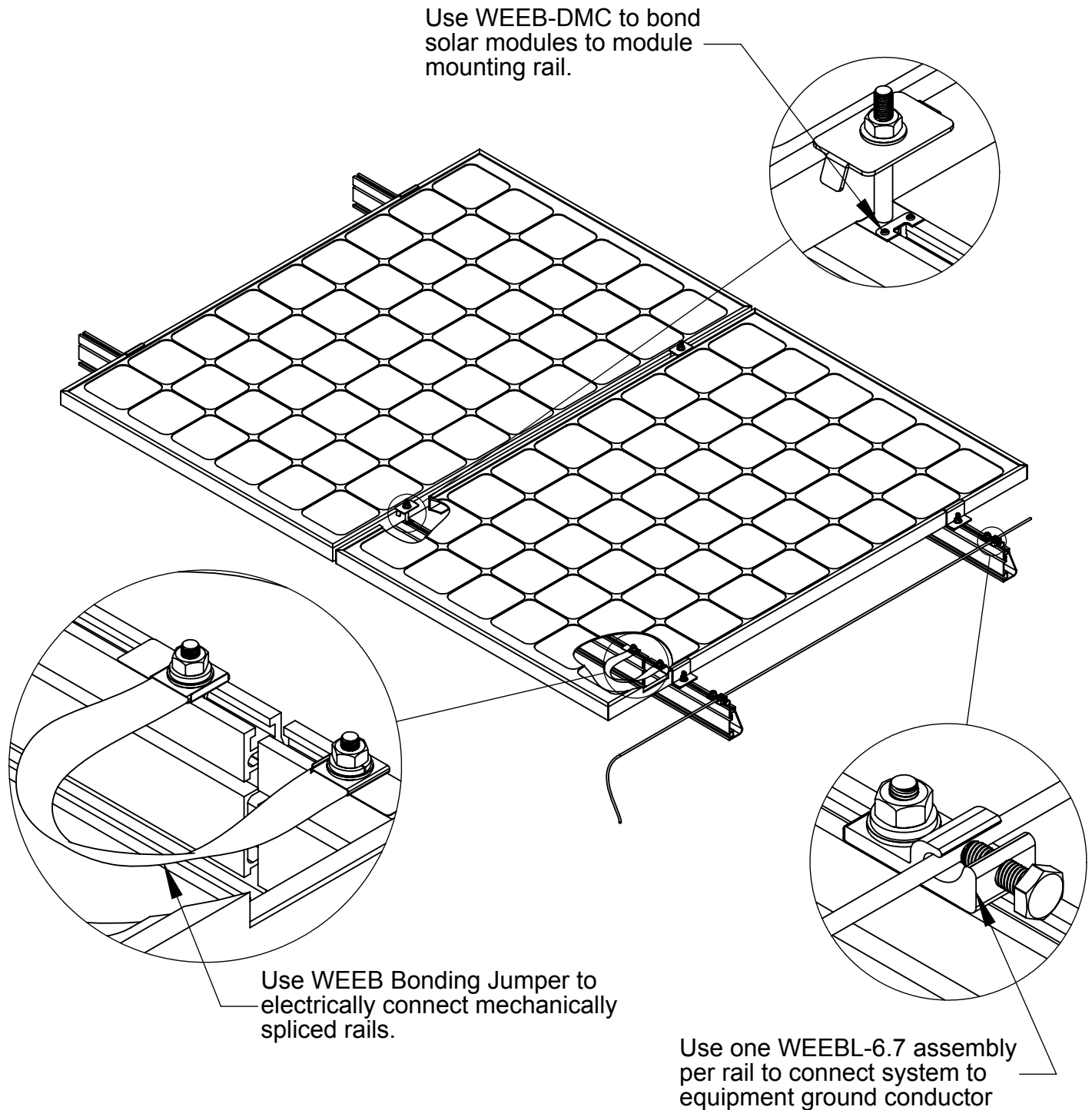

Important notes:

1. Use general purpose anti-seize compound on fastener threads when installing WEEBs.
2. WEEBs are intended for **SINGLE USE ONLY**. Functionality will not be guaranteed if reused.

WEEB-DMC ASSEMBLY

①

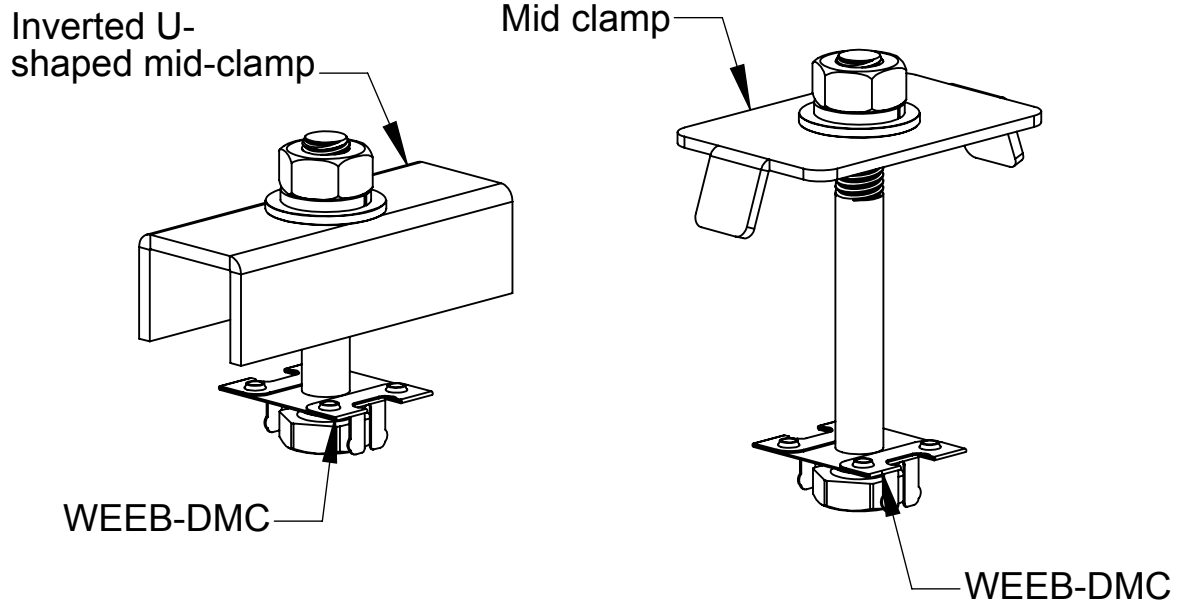

Pre-assemble WEEB-DMC to mid clamp assembly as shown. Pre-assembling WEEB-DMC to mid clamp assembly will contain the small individual parts, reducing the possibility of losing parts during installation.

②

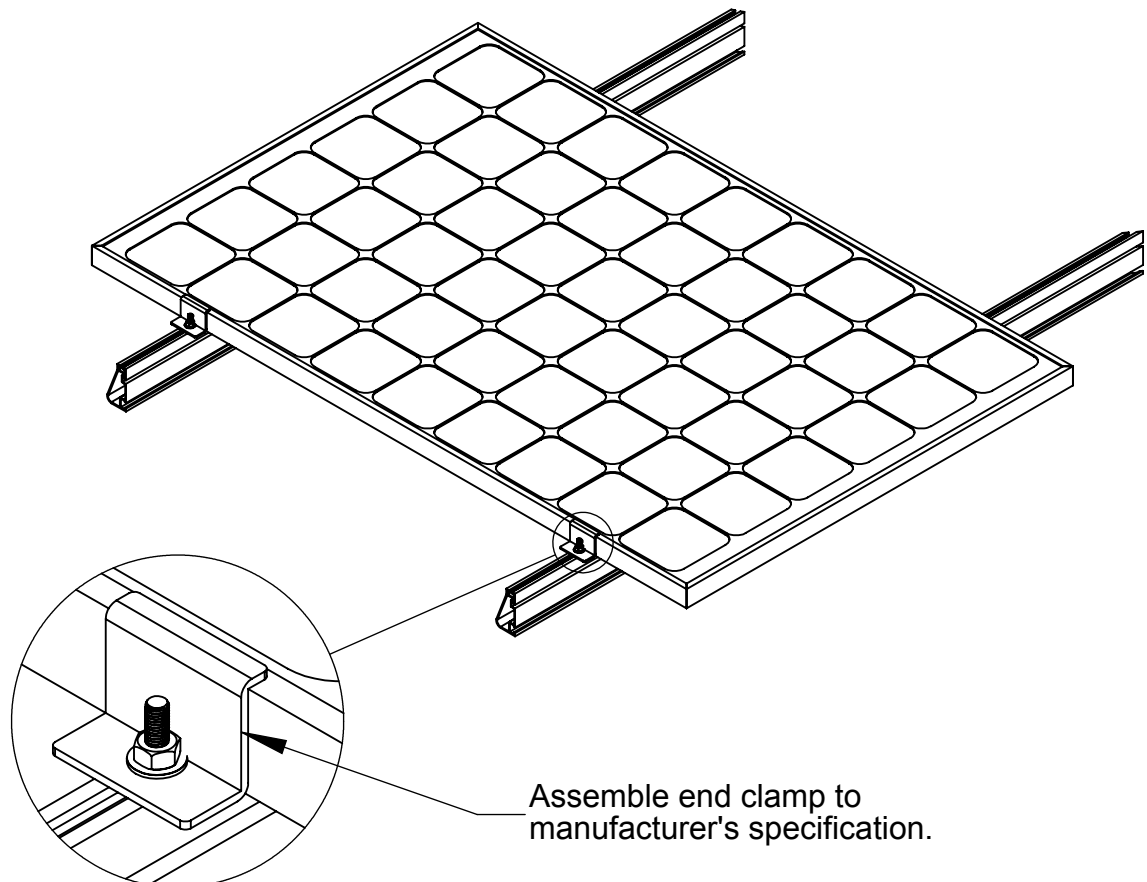

3

Slide pre-assembled
WEEB-DMC and mid clamp
assembly into position.

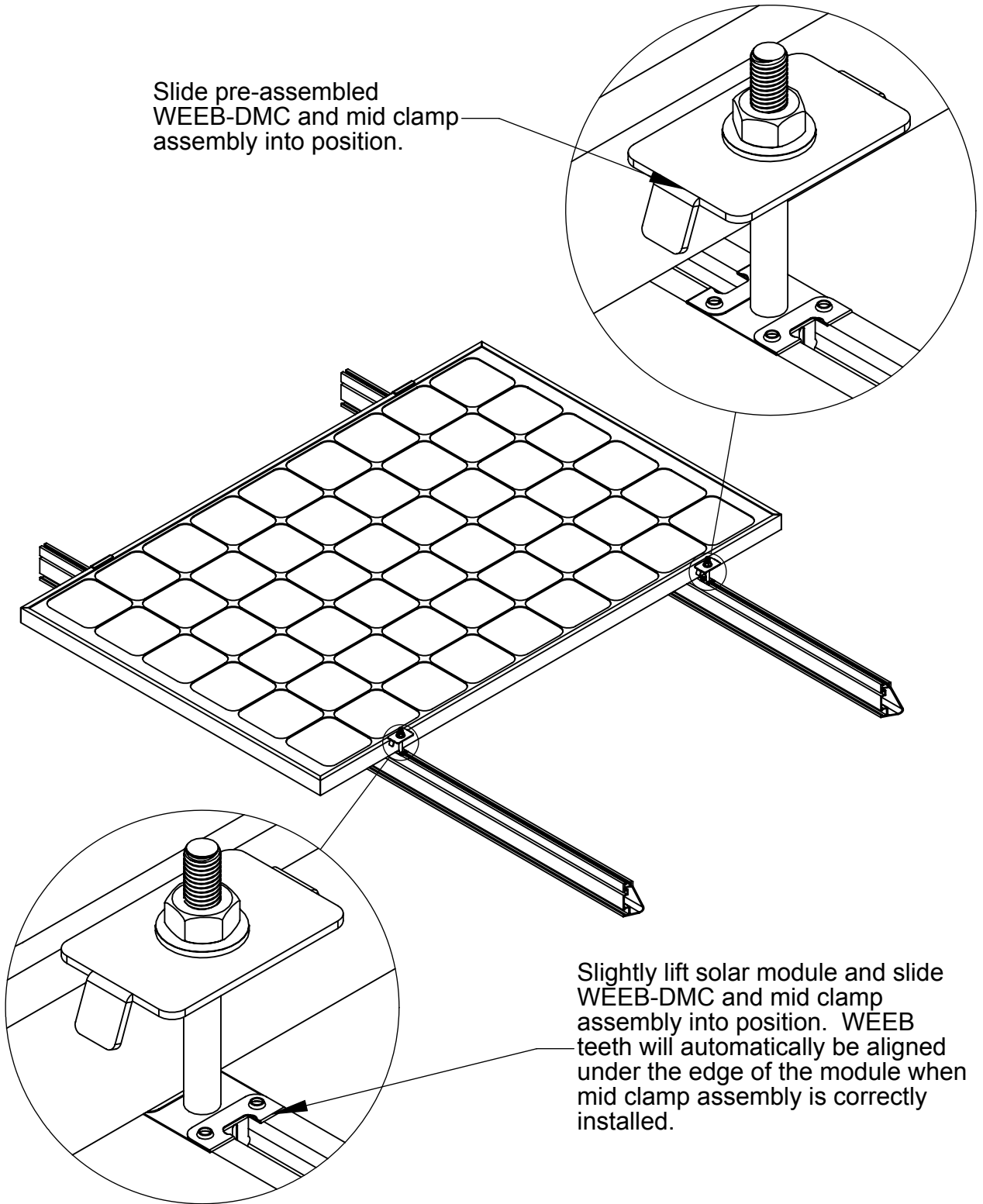

Important note:

To correctly install mid clamp assembly, ensure that the bolt is perpendicular to the mounting rail and both sides of the solar modules are completely positioned against the mid clamp. Refer to WEEB compatibility page for illustrations.

- ④ **Important note:**
WEEBs are for SINGLE USE ONLY! Do not torque fasteners down if position of solar modules is not finalized. Only slightly tighten fasteners to keep modules in place.

When position of solar modules is finalized, tighten fasteners to 10 ft-lb / 13.5 N-m using general purpose anti-seize compound on threads.

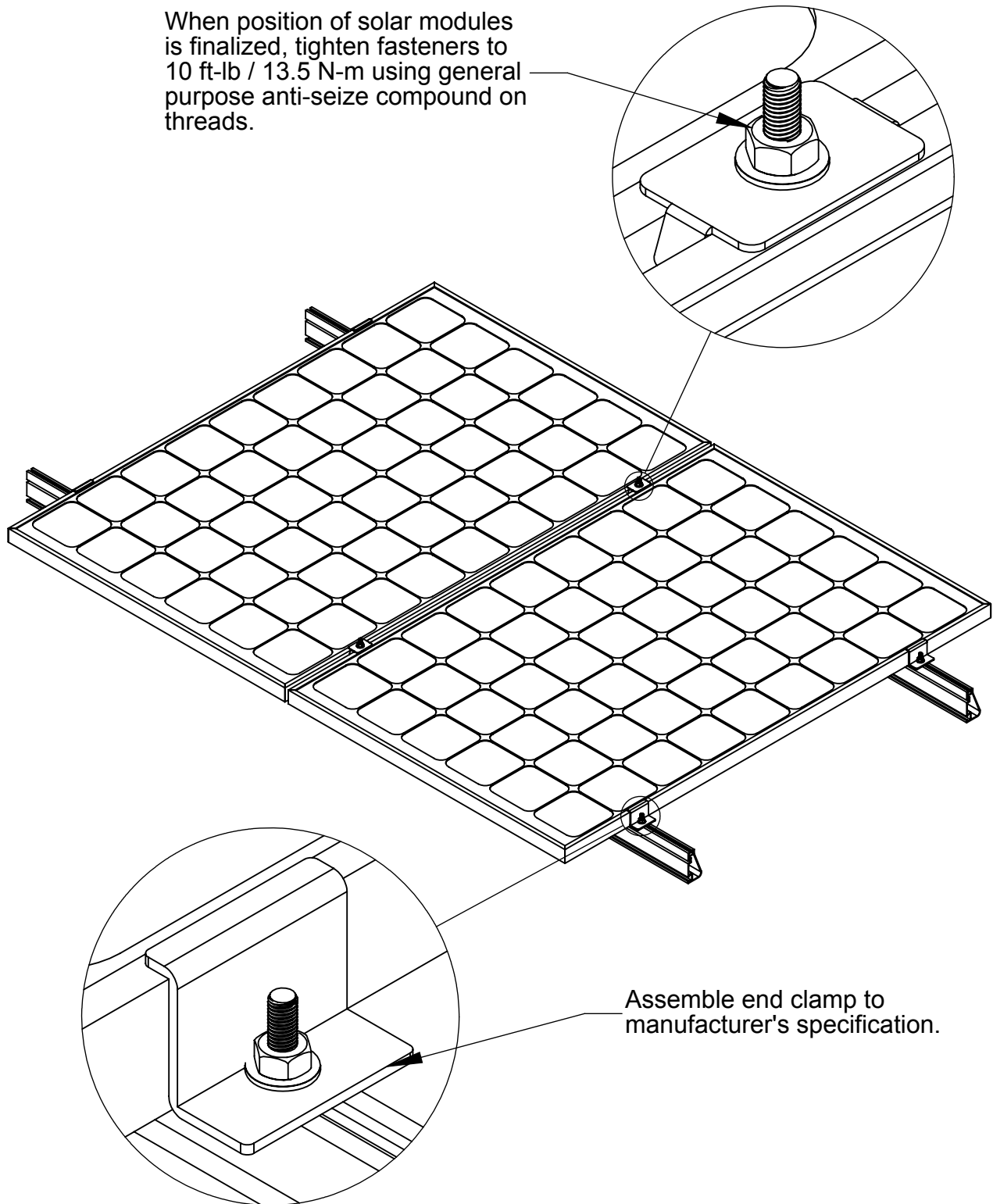

Assemble end clamp to manufacturer's specification.

WEEB-DMC LAYOUT

EVEN NUMBER OF MODULES IN ROW

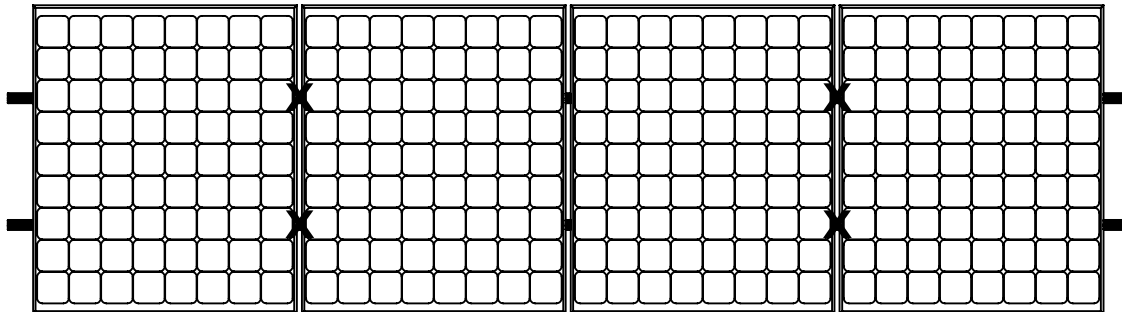

X DENOTES PLACES TO INSTALL WEEB-DMC

$$C \times R = 4 \times 1$$

$$\text{WEEB-DMC NEEDED} = C \times R = 4 \times 1 = 4$$

ODD NUMBER OF MODULES IN ROW

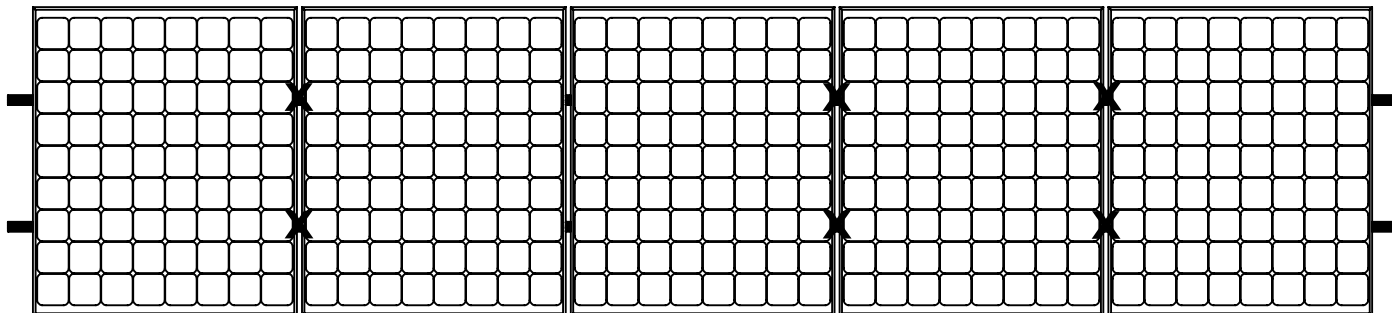

X DENOTES PLACES TO INSTALL WEEB-DMC

$$C \times R = 5 \times 1$$

$$\text{WEEB-DMC NEEDED} = [C+1] \times R = [5+1] \times 1 = 6$$

Note:

When replacing a single faulty module, also remove the adjacent module which contacts the same WEEBs as the faulty module. This will ensure that there are never ungrounded modules in the array.

WEEBLUG ASSEMBLY

5

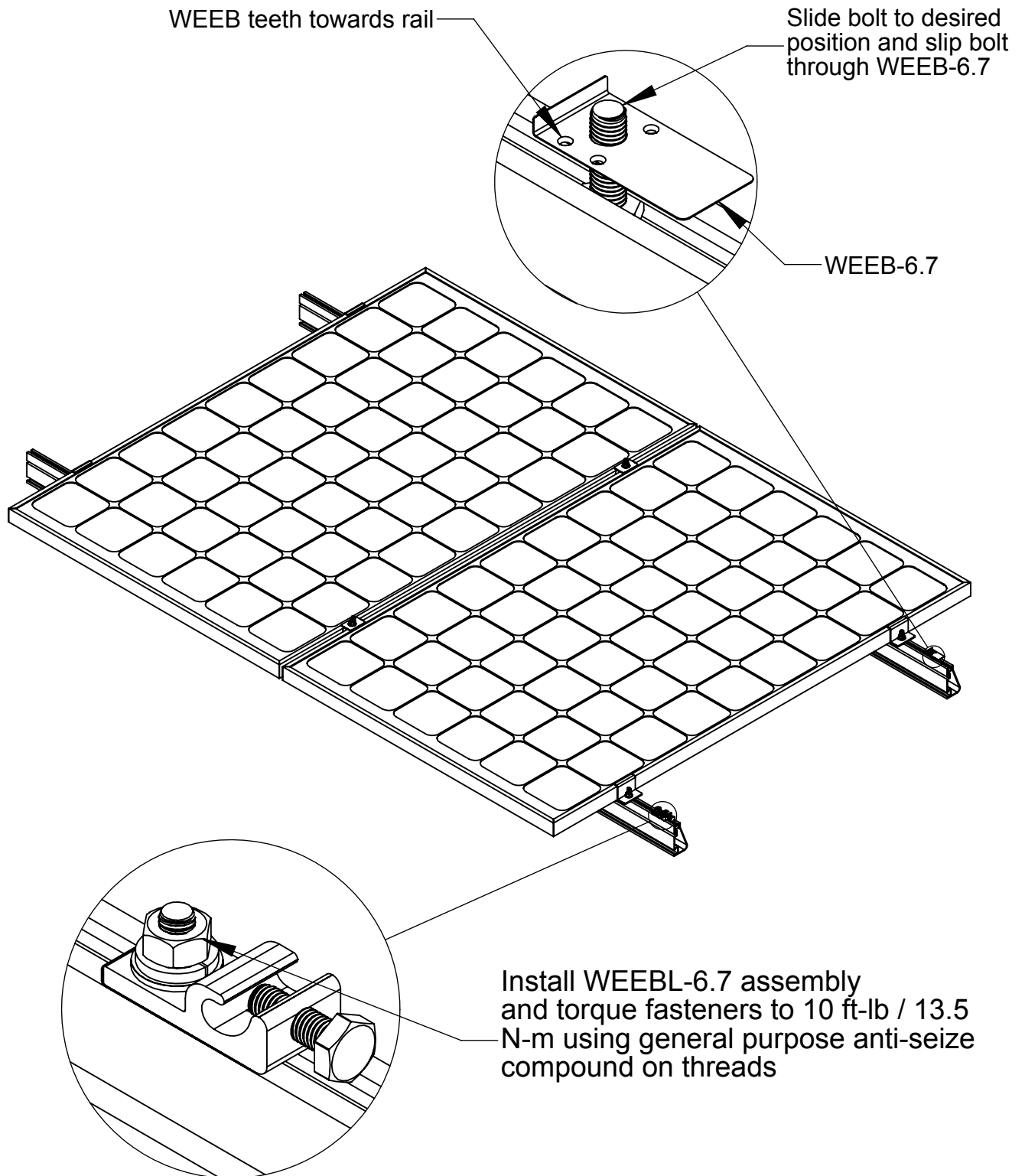

Important note:

WEEB-6.7 that sits under the WEEBLug is for single use only. Ensure position is correct before tightening down.

6

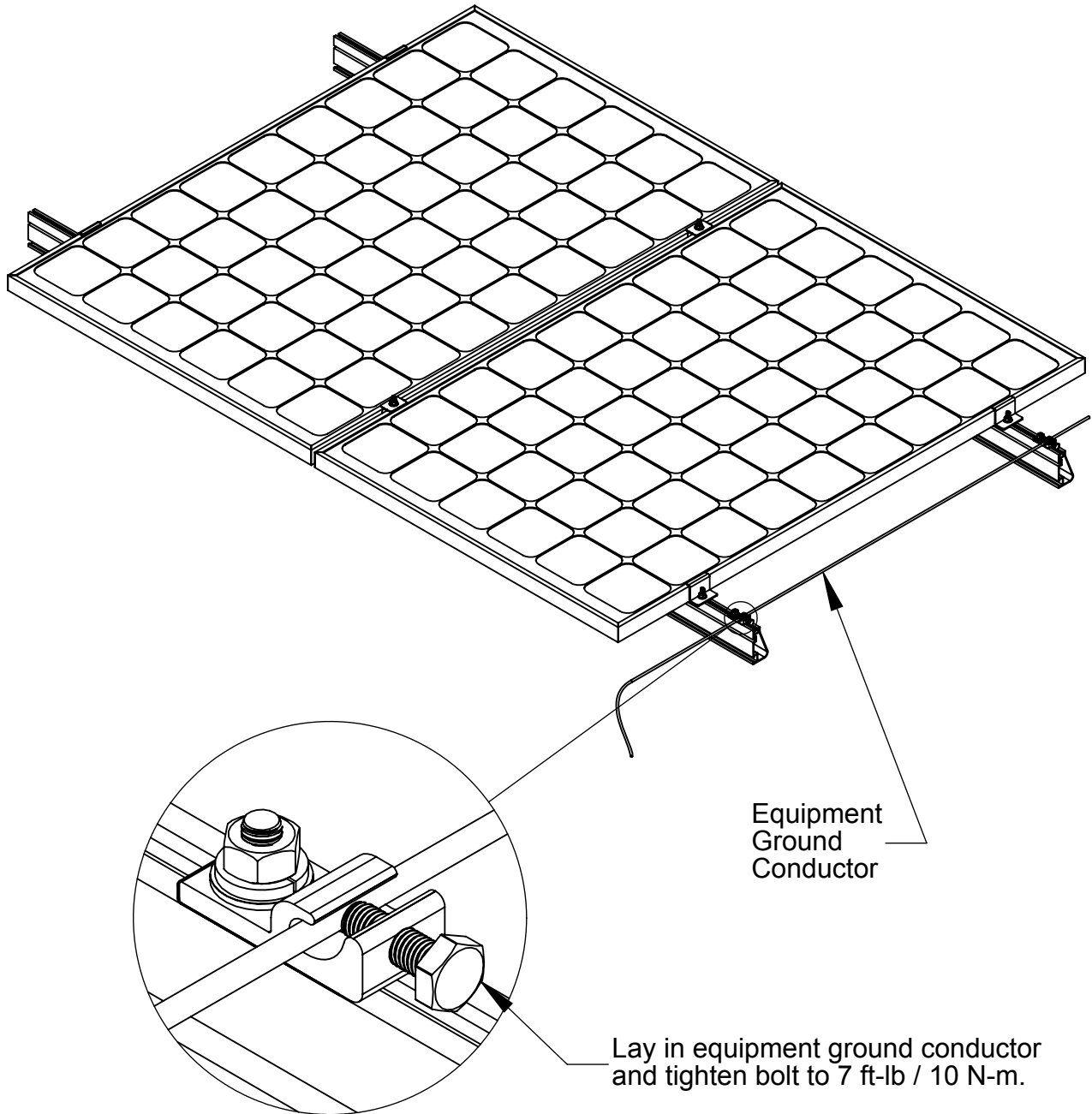

IRONRIDGE SPLICE KIT ASSEMBLY

- ⑦ The flexible WEEB Bonding Jumper can be mounted in different ways shown below.

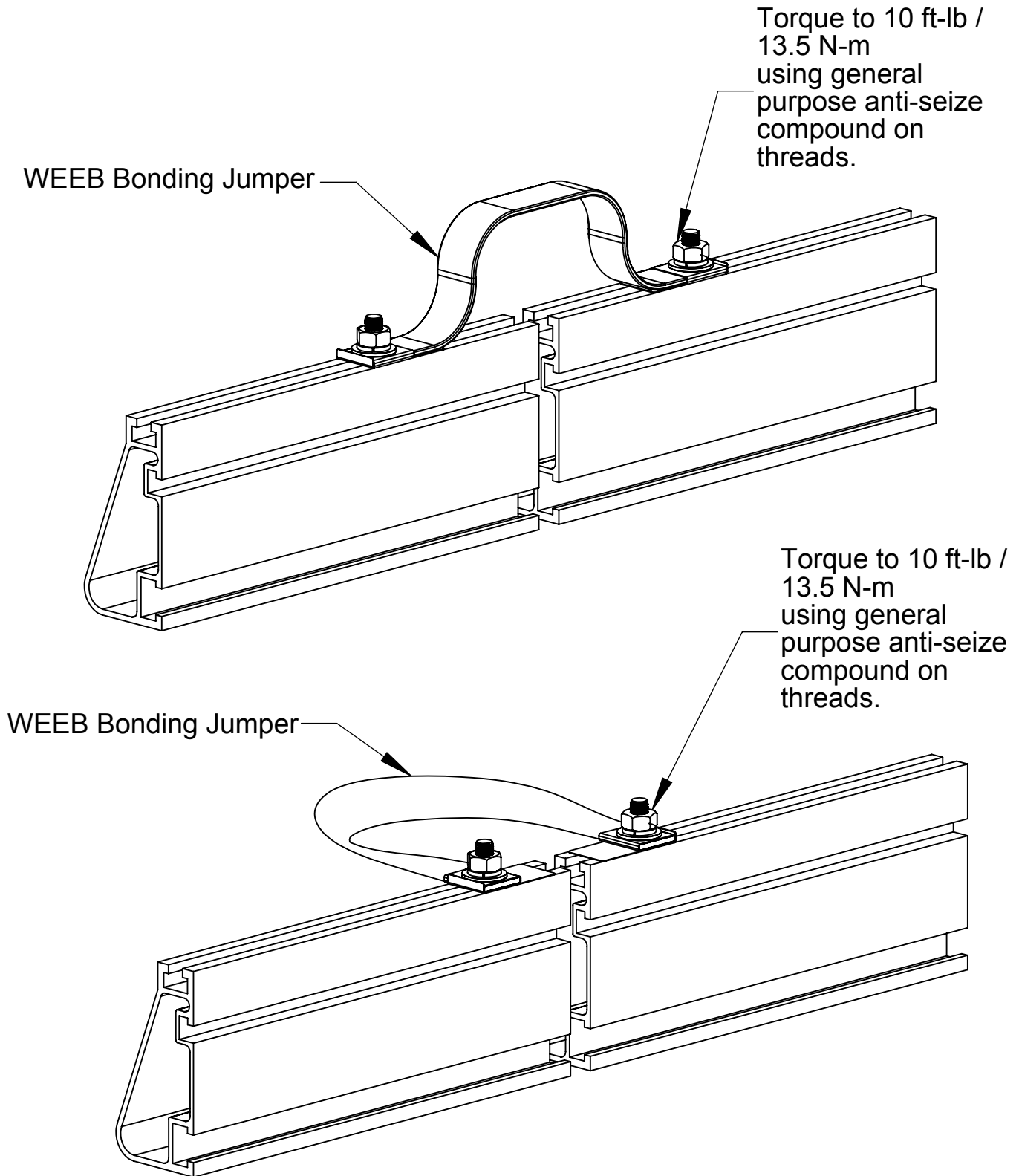

Route WEEB Bonding Jumper as shown above if edge of solar module lands between two splice rails.

LOW-LIPPED MODULE INSTALLATION

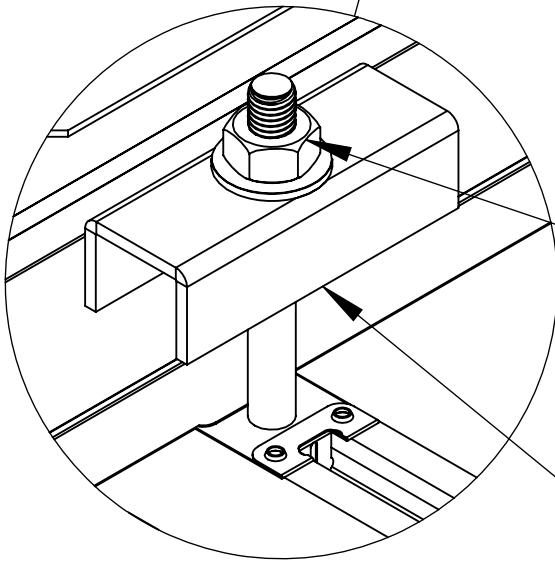
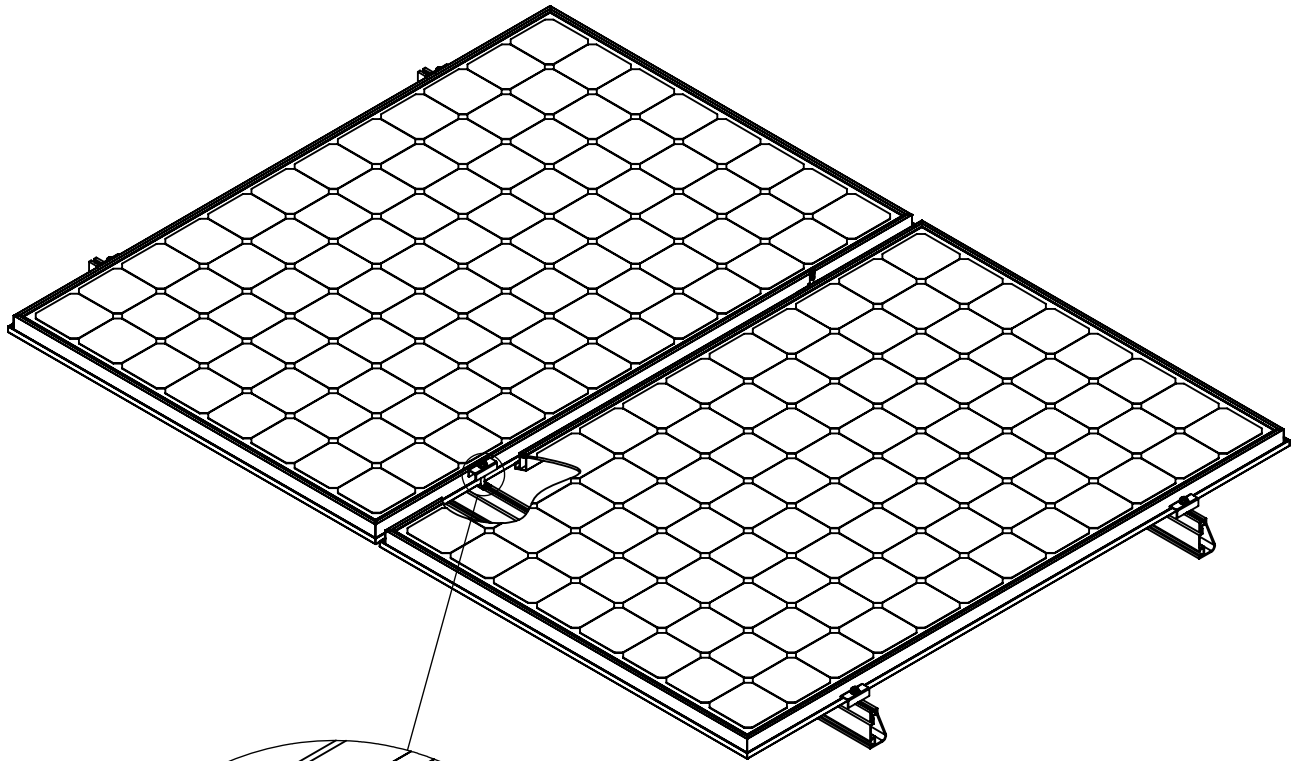

Tighten to 10 ft-lb / 13.5 N-m using general purpose anti-seize compound on threads.

Inverted U-shaped mid clamp

Standard Rail^(XRS) Roof Mounting System

2012 Edition v1.2

This **Installation Manual** was created to help with the assembly of the IronRidge Standard Rail Mounting System.

Standard Rail

- 1 Introduction
 - Installer Responsibility
 - Customer Support
 - Tools Required For Assembly
 - Torque Values For Dry Bolts
- 2 Grounding Setup
 - Component List
- 3 Assembly: Step 1
 - Assembly: Step 2
- 4 Assembly: Step 2
- 5 Assembly: Step 3
- 6 Assembly: Step 3
- 7 Warranty Information

Introduction

The IronRidge Standard Rail System is a flexible and straightforward roof mounting solution for a wide variety of solar photovoltaic (PV) needs. Due to its modular design, it can easily handle a wide variety of panel sizes and quantities.

Installer Responsibility

The installer is solely responsible for:

- i. Complying with all applicable local or national building codes, including any that may supersede this manual;
- ii. Ensuring that IronRidge and other products are appropriate for the particular installation and the installation environment;
- iii. Ensuring that all structural support members, including the roof, its rafters, and connections, can support the array under all code level loading conditions;
- iv. Using only IronRidge parts and installer-supplied parts as specified by IronRidge. Substitution parts may void the warranty;
- v. Ensuring that anchoring devices including lag screws have adequate pullout strength and shear capacities as installed;
- vi. Maintaining the waterproof integrity of the structural support or roof, including selection of appropriate flashing;
- vii. Ensuring safe installation of all electrical aspects of the PV array; and
- viii. Ensuring correct and appropriate design parameters are used in determining the design loading used for the specific installation. Parameters, such as snow loading, wind speed, exposure and topographic factor should be confirmed with the local building official or a licensed professional engineer.

Customer Support

IronRidge makes every effort to ensure your mounting kit is easy to install. If you need assistance at any point with your installation or have suggestions on how we can improve your experience, call IronRidge customer support: (707) 459-9523

Tools Required For Assembly

Wrenches are required to assemble the IronRidge Standard Rail System. An open-end wrench, box-end wrench, or socket drive with sockets will suffice. The sockets will need to support the following size hex heads:

Hex Head Size	Component
5/16"	#12 Self-drilling/tapping screws
7/16"	1/4 cap-end screws and bolts
9/16"	3/8 cap-end screws and bolts

Torque Values For Dry Bolts

Use the following torque values in this assembly.

Bolt Size	Required Torque Value
1/4-20	120 in-lbs.
3/8-16	236 in-lbs.

Grounding Setup

All electrical installation and procedures should be conducted by skilled, licensed and bonded electricians. All work must comply with all national, state and local installation procedures, product and safety standards. These standards include but are not limited to applicable National Electrical Code (NEC®), National Electrical Installation Standards (NEIS™), UL Standards, and OSHA Regulations.

Note: For installations that utilize WEEBs, WEEB Lugs and WEEB Bonding Jumpers, please refer to Wiley/Burndy installation manual for "IronRidge Light and Standard Series Rail" for proper installation procedures.

Component List

The IronRidge Standard Rail System contains the following parts:

L-Foot

Attaches to the roof and is the anchor point for the rest of the panel assembly.



Internal Splice

Ties the extrusion rails together, extending their length.

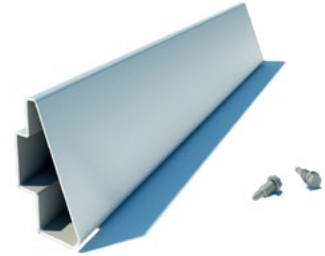

Standard Rail

Attaches to the foot via foot clamp and provides support for the PV modules.



End Clamp

Clamps the outside ends of the PV modules to the rails.



Mid Clamp

Clamps the insides edges of the PV modules to the rails.



End Cap

Caps off the end of the rail and prevents the collection of debris inside rail.



Assembly

Step 1. Mounting the feet and the first piece of rail.

- A.** Mount all of the feet to the roof in the desired locations.

Note: Determine the maximum distance between feet according to engineering specifications.



- B.** On the first piece of rail, slide 3/8-16" bolts into the side facing t-slot on the rail. Space the bolts out to match the foot spacing.

- C.** On this same piece of rail, slide 1/4-20" bolts into the top facing t-slot on the rail. Space the bolts out to match the panel spacing.

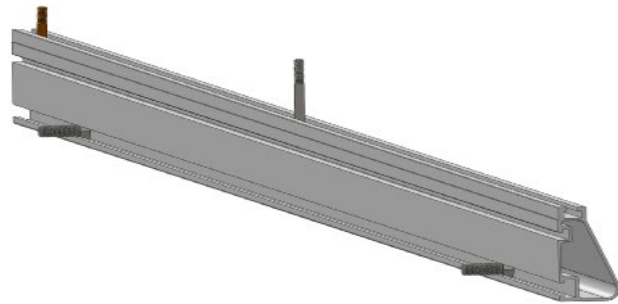

- D.** Attach this first piece of rail to the feet mounted on the roof. Mount the rail to each foot with a flange nut and hex bolt. Hand tighten the nuts and check the level of the rail. Tighten 3/8-16 hardware to 236 in-lbs.

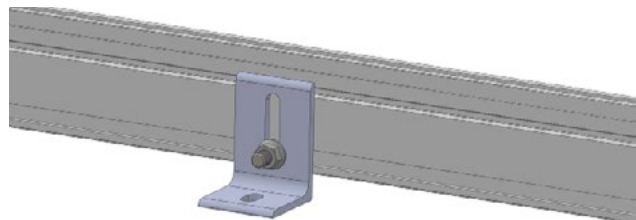

Step 2. Mounting the next pieces of rail.

- A.** On the next piece of rail, slide 3/8-16" bolts into the side facing t-slot on the rail. Space the bolts out to match the foot spacing.

- B.** On this same piece of rail, slide 1/4-20" bolts into the top facing t-slot on the rail. Space the bolts out to match the panel spacing.

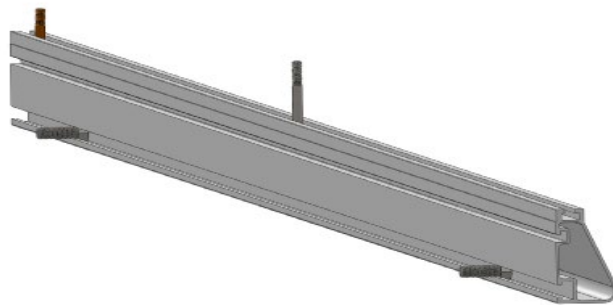

- C.** Lay the rail on its side, with the slotted side down as shown.
- D.** Slide the internal splice half way into the internal cavity in the rail. It should extend approximately six (6) inches into the cavity.

- E.** Using one (1) self-drilling, self-tapping screw, one (1") inch from the edge of the rail, secure the internal splice into the rail as shown on the right.

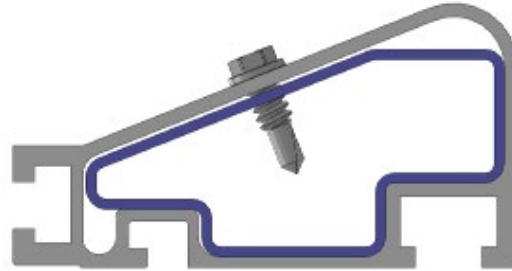

Note: For installations that utilize WEEB Bonding Jumpers, please refer to Wiley/Burndy installation manual for "IronRidge Light and Standard Series Rails" for proper installation procedures.

- F.** Loosely mount this piece of rail onto its footings.
- G.** By moving this second rail along its footings, the internal splice should slip into the cavity on the first rail, with the rails butting tightly and evenly together.

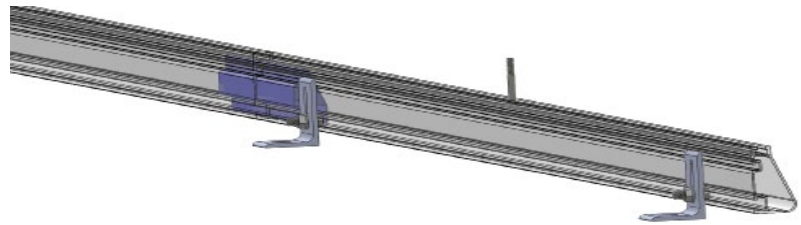

- H.** Maintain rail alignment while following the next steps.
- I.** You should mark off approximately six (6) inches from the end of the first rail (where the internal splice should end). Drive one (1) self-tapping screws through the second rail, one (1") inch from the edge utilizing the same horizontal location as the first rail.
- J.** Repeat this procedure for the remaining rails.

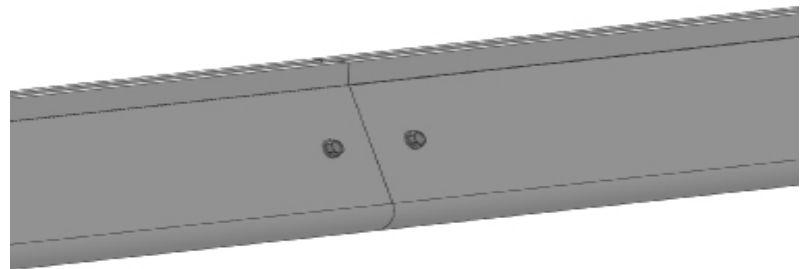

Step 3. Clamping the panels to the rails.

- A.** Lay the first PV module in position on the rails.

Note: For installations that utilize WEEBs, please refer to Wiley/Burndy installation manual for "IronRidge Light and Standard Series Rails" for proper installation procedures.

- B.** Then slip the end clamp over the bolt, making sure it is firmly hooked over the side of the module.

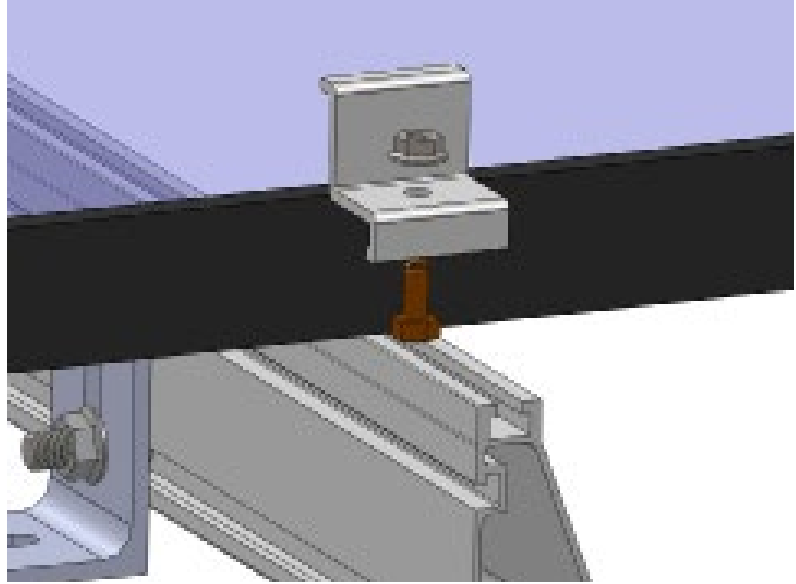

- C.** Complete the clamp assembly with a flange nut as shown. Tighten to 60-65 in-lbs.

- D.** Repeat with the other clamp.

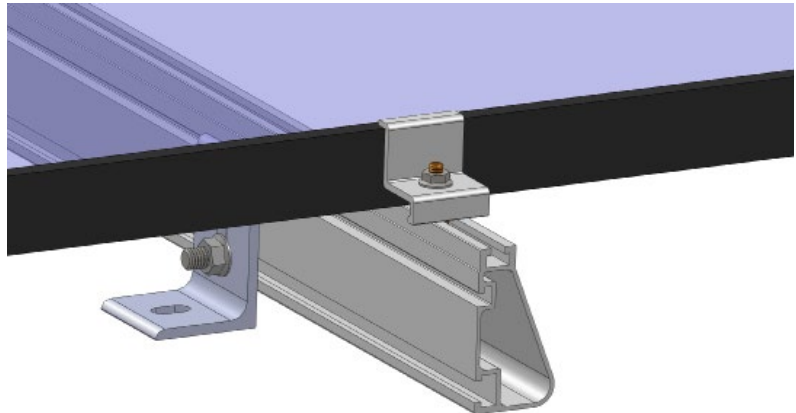

- E.** Working from the opposite side of the PV module. Assemble the mid clamps by putting a clamp on the bolt, followed by the flange nut.

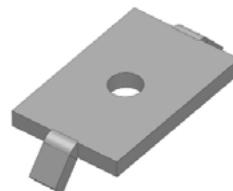

F. Place the second PV Module into position on the rails, sliding it against the first so the mid clamps are in contact with the edges of both panels.

Note: For installations that utilize WEEBs, please refer to Wiley/Burndy installation manual for "IronRidge Light and Standard Series Rails" for proper installation procedures.

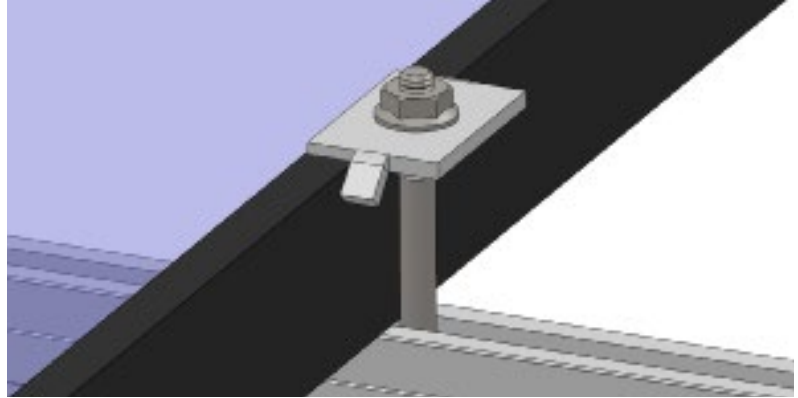

G. Tighten to 10 ft-lbs (120 in-ilbs).

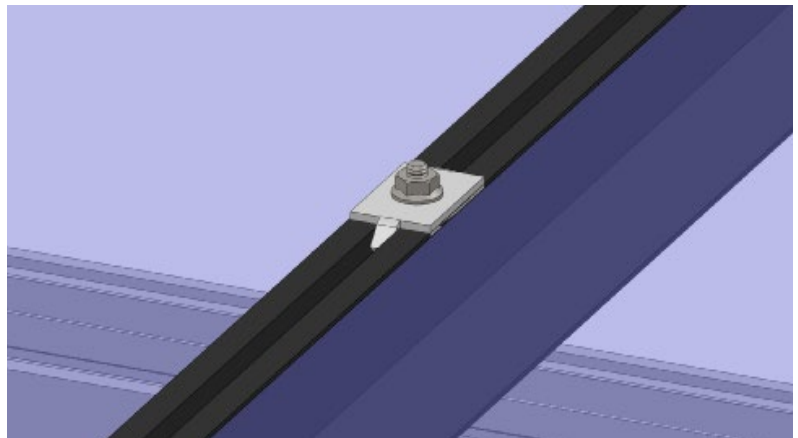

H. Repeat the procedure using mid clamps to secure each successive module.

I. Secure the last module at the end of the rails using the other set of end clamps.

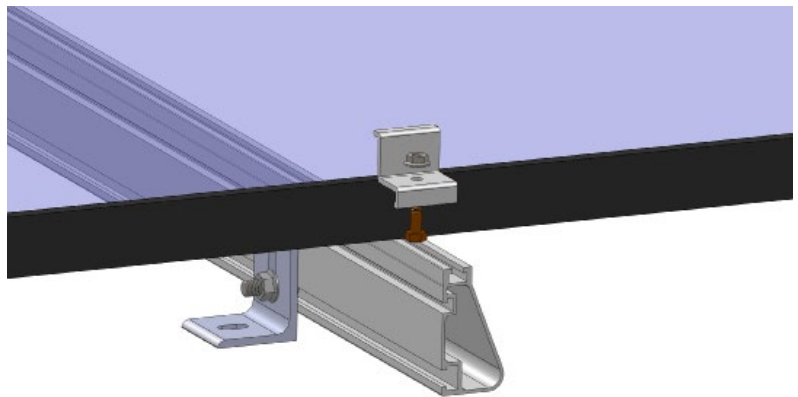

Warranty Information

Effective for IronRidge, Inc. (“IronRidge”) mounting structure components (“Products”) manufactured after April 1st, 2012, IronRidge provides the following warranties, for Products installed properly and used for the purpose for which the Products are designed:

- finishes shall be free of visible defects, peeling, or cracking, under normal atmospheric conditions, for a period of three (3) years from the earlier of (i) the date of complete installation of the Product or (ii) thirty days after the original purchaser’s date of purchase of the Product (“Finish Warranty”);
- components shall be free of structurally-related defects in materials for a period of ten (10) years from the earlier of (i) the date of complete installation of the Product or (ii) thirty days after the original purchaser’s date of purchase of the Product;
- components shall be free of functionally-related manufacturing defects for a period of twenty (20) years from date of manufacture.

The Finish Warranty does not apply to: (a) surface oxidation of the galvanized steel components or any foreign residue deposited on Product finish; and (b) Products installed in corrosive atmospheric conditions, as defined solely by IronRidge; corrosive atmospheric conditions include, but are not limited to, conditions where Product is exposed to corrosive chemicals, fumes, cement dust, salt water marine environments or to continual spraying of either salt or fresh water. The Finish Warranty is VOID if (c) the practices specified by AAMA 609 & 610-02 – “Cleaning and Maintenance for Architecturally Finished Aluminum” (www.aamanet.org) are not followed by Purchaser for IronRidge’s aluminum based components; and (d) if the practices specified by ASTM A780 / A780M - 09 “Standard Practice for Repair of Damaged and Uncoated Areas of HotDip Galvanized Coatings” are not followed by Purchaser for IronRidge’s galvanized steel-based components.

The warranties above do not cover any parts or materials not manufactured by IronRidge, and exclude nonfunctionally-related defects, as defined solely by IronRidge. The warranties do not cover any defect that has not been reported to IronRidge in writing within twenty (20) days after discovery of such defect.

In the event of breach of or non-compliance with the warranties set forth above, IronRidge’s sole obligation and liability, and the sole and exclusive remedy for such breach or non-compliance, shall be correction of defects by repair, replacement, or credit, at IronRidge’s sole discretion. Such repair, replacement or credit shall completely satisfy and discharge all of IronRidge’s liability with respect to these warranties.

Refurbished Product may be used to repair or replace the defective components. Transportation, installation, labor, or any other costs associated with Product replacement are not covered by these warranties and are not reimbursable. These warranties additionally do not cover (a) normal wear, or damage resulting from misuse, overloading, abuse, improper installation (including failure to follow professional instruction and certification), negligence, or accident, or from force majeure acts including any natural disasters, war or criminal acts; and (b) Products that have been altered, modified or repaired without written authorization from IronRidge or its authorized representative; and (c) Products used in a manner or for a purpose other than that specified by IronRidge. A formal document proving the purchase and the purchase date of the Product is required with any warranty claim.

Except as set forth above, IronRidge sells the Products on an “AS IS” basis, which may not be free of errors or defects, and ALL EXPRESS OR IMPLIED REPRESENTATIONS AND WARRANTIES, INCLUDING ANY WARRANTIES OF MERCHANTABILITY, FITNESS FOR A PARTICULAR PURPOSE, QUALITY, WORKMANLIKE EFFORT, CORRESPONDENCE TO DESCRIPTION, DESIGN, TITLE OR NON-INFRINGEMENT, OR ARISING FROM COURSE OF DEALING, COURSE OF PERFORMANCE OR TRADE PRACTICE, ARE HEREBY DISCLAIMED.